

Q = C V capacitor experiment using an LM334Z current source

We like the usual capacitor experiment where we manually change the value of a series variable resistor in order to try maintain a constant charging current. There is educational merit in trying to vary the resistor at noticeably different rates and reaching a point where this is no longer possible. Noting this current, the time and the voltage across the capacitor allows the calculation of Q, the charge, from $Q = It$ where I is the constant charging current, and enables a graph of Voltage v Charge to be plotted. The gradient of this graph, Q/V , is the value of the capacitance of the capacitor being charged.

We received a query about the construction of a constant current circuit for use in the above experiment. We had previously used a single, silicon, NPN transistor constant current circuit successfully.

As the enquiry was about the use of an LM334Z integrated circuit we ordered some [1] and set about doing the experiment.

The LM334Z is a three pin device, it comes in a TO92 style package, and has a maximum device current of 10 mA.

In the most basic configuration the addition of a single resistor is all that is needed to set the value of the constant current (Figure 2). Online information states that the value of this resistor can be calculated using

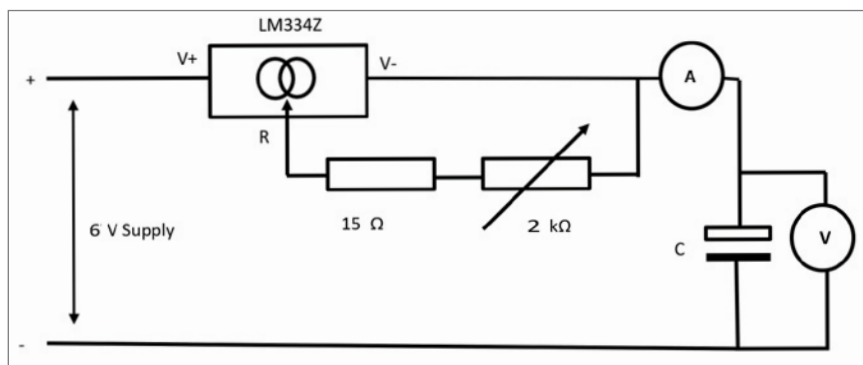

Figure 1 - The circuit diagram of the LM334Z constant current source in the capacitor experiment.

the equation: $R_{set} = 67.7 \text{ mV} / I_{set} \cdot I_{set}$ is the desired constant current and R_{set} is the total value of resistance between the R and V- pins of the LM334Z.

A 68 Ω resistor would give a current of approximately 1 mA, 136 Ω would give about 0.5 mA.

Instead of using a single fixed value resistor we used a combination of a fixed resistor (15 Ω to limit the max value of current to just under 5 mA, well under the device's max current) in series with a 2000 Ω multi-turn preset resistor (Figure 1 and 4). This allowed us to vary the value of the current but not exceed its maximum

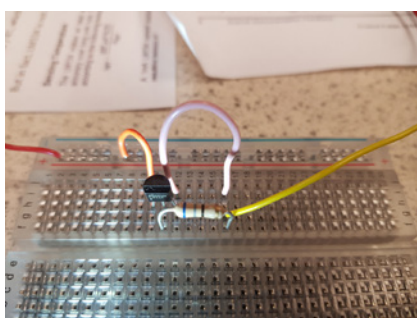

Figure 2 - The LM334Z prototype circuit with 15 Ω resistor giving a constant current of 0.98 mA.

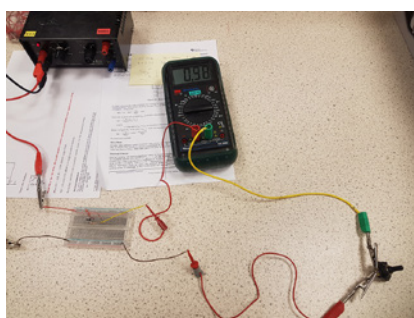

Figure 3 - Using a 500 Ω variable resistor to confirm constant current over a range of load resistances.

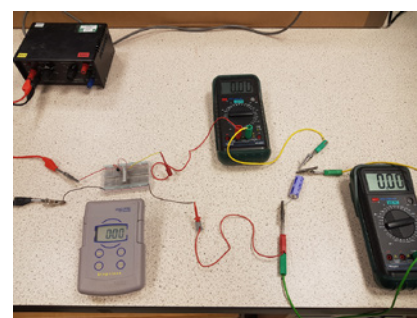

Figure 4 - The capacitor experiment as shown in Figure 1.

Activities & professional learning

current capability. The ammeter is only required when setting the current. Circuit diagram - For the datasheet and pinout information see [2].

To set the value of the current use a 500 Ω variable load resistor (in place of the capacitor) and an ammeter (Figure 3). Adjust the multiturn preset resistor until the ammeter displays the desired current.

Results

The spreadsheet in Figure 5 shows typical results using a 2200 μF electrolytic capacitor with the current set to 0.1 mA. The Voltages on the Voltmeter were noted every 5 s. The calculated value of capacitance was 2501 μF. Electrolytic capacitors have a wide tolerance range, typically +/- 20%!

The area under the best fit straight line (calculated from the integral of the equation of best fit) is also compared to the Energy ($\frac{1}{2} QV$) stored in the capacitor.

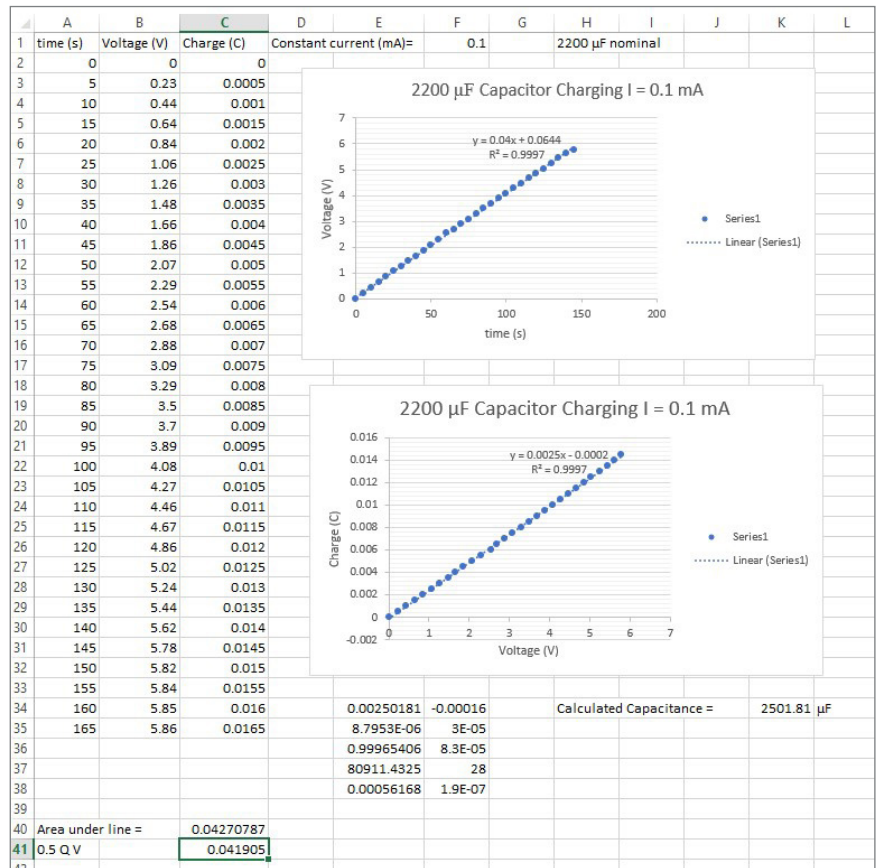

Figure 5 - Typical results for a 2200μF capacitor.

References

- [1] <https://www.bitsbox.co.uk/>
- [2] https://www.ti.com/lit/ds/symlink/lm334.pdf?ts=1649740909939&ref_url=https%253A%252F%252Fwww.ti.com%252Fproduct%252FLM334%253Futm_source%253Dgoogle%2526utm_medium%253Dcpc%2526utm_campaign%253Dapp-null-null-GPN_EN-cpc-pf-google-eu%2526utm_content%253DLM334%2526ds_k%253DLM334%2526DCM%253Dyes%2526gclid%253Daw.ds%2526gclid%253DCjwKCAjwo8-SBAlEiwAopc9W1WoVoWyhAnz10DA6VQCNejUXWUia WVIHY9eV5p6_AfOw-liUMKzBoCOD0QAvD_BwE