

Sodium absorption spectrum with a white Lumiled LED source

The D lines of the sodium absorption spectrum can be displayed reliably and easily with the aid of a high-power, white-light, LED source such that the demonstration can be shown in daylight.

Description

With apparatus that is easily set up, radiation from an intense white-light source is focused on a sodium vapour flame. The fraction of light transmitted through the flame is refocused on the aperture of a hand spectroscope, thus demonstrating with little trouble the D lines of the sodium absorption spectrum.

This demonstration experiment requires a little over one metre of bench space, with a gas supply for running a Bunsen. The principal axis of the radiation should be set at around 200 mm above the bench to accommodate the height of the Bunsen funnel, sodium pencil and flame (Fig. 1).

The demonstration can be carried out in daylight because the radiation from the 1 W white Lumiled (Lumiled Luxeon 1W Star with Optic (Low Dome Batwing) Enhanced-White LXH-NWE8, RS, 467-7519, £10.49) is sufficiently bright. What makes the experiment so easy to perform is the nature of the white-light radiation source. The LED, mounted on a heatsink, should be run off a 5 V voltage-regulated supply capable of delivering at least 350 mA of current. There should be a parallel combination of resistors, 10 Ω and 22 Ω , both rated 3 W, wired in series with the LED (Fig. 2). For information on wiring a Lumiled and fitting a heatsink, please refer to Bulletin 210, p8, and the SSERC website:-

<http://www.sserc.org.uk/members/bulls/210/physics.htm#Product%20description>

Referring to Figure 1, radiation from the white Lumiled LED (A) is focused on a spot (C) above a Bunsen with a 50 mm diameter converging lens ($f = 100$ mm) (B). Radiation is re-collected with another 50 mm diameter lens ($f = 100$ mm) (D) and focused on the entrance aperture (E) of a hand spectroscope mounted on a clamp stand. Separations between each element (A – E) should be roughly as shown (Fig. 1).

The lens types have been optimized for the application. Because the LED has what is not quite accurately called a 'collimating lens', the LED emits a narrow beam of white light that has a small amount of divergence. At the first converging lens (B), the beam width has broadened out to just over 50 mm, completely filling this lens. This lens therefore captures most of the LED's radiation and brings the radiation to a focus in the sodium flame. The white light radiation that gets transmitted through the flame diverges to fill the

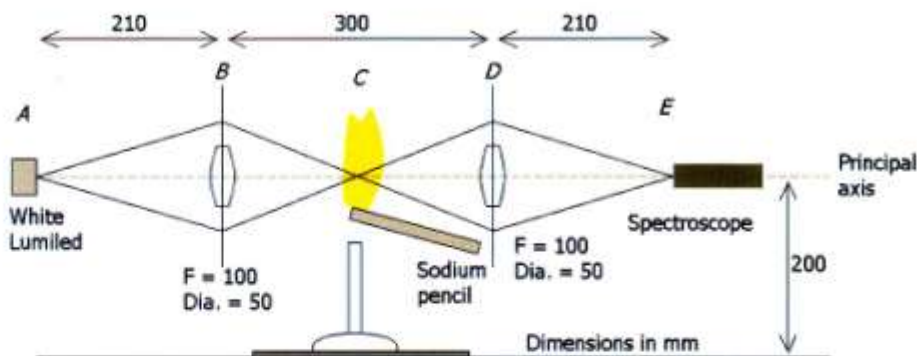

Fig.1 Schematic diagram showing the optical parts. When these specifications are applied, relatively little radiation is lost.

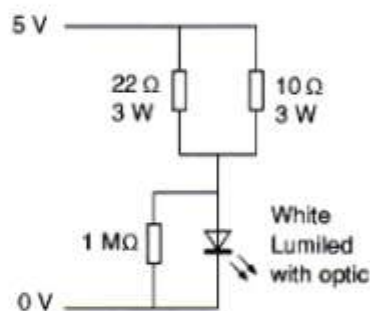

Fig.2 Circuit diagram.

second lens (D), which gathers it to refocus on the entrance aperture of the hand spectroscope. Because relatively little white light gets lost on its way to the spectroscope, the spectrum in the spectroscope is stunningly vivid.

Other lenses that could be substituted include condenser lenses, or fresnel ones. The specified focal lengths are given for guidance, but generally should lie between 100 and 150 mm.

In the photographs illustrating this article (Figs. 3 & 4), the lenses shown have diameters of 75 mm – not 50 mm as recommended in the text – and focal lengths of 150 mm. During our research, we found that the smaller size of lens is adequate and is recommended since it is a standard size held by schools. The complete setup is shown in Figure 3; while in Figure 4, the method for setting the positions of the sodium pencil and Bunsen funnel is shown: the

focus is about 3 – 4 cm above the tip of the pencil, which is a similar height above the funnel. A second spectroscope can be mounted above the first (E) to observe the sodium emission spectrum.

With sodium pencils no longer available, an effective substitute can be made by rolling two sheets of large diameter filter paper into a tight roll and soaking one end in a saturated solution of sodium chloride and water. The dry end is clamped to a stand with the wet tip pointing slightly upwards and at a height of about 30 mm above the Bunsen funnel. This should give a sodium flame lasting 20 minutes or more. The only critical adjustment is ensuring that the flame transects the LED radiation. When this happens, an absorption line (the two D lines can be resolved with some makes of spectroscope) will be clearly seen through the spectroscope, while the corresponding emission line (or pair of lines) can be seen with the white source covered.

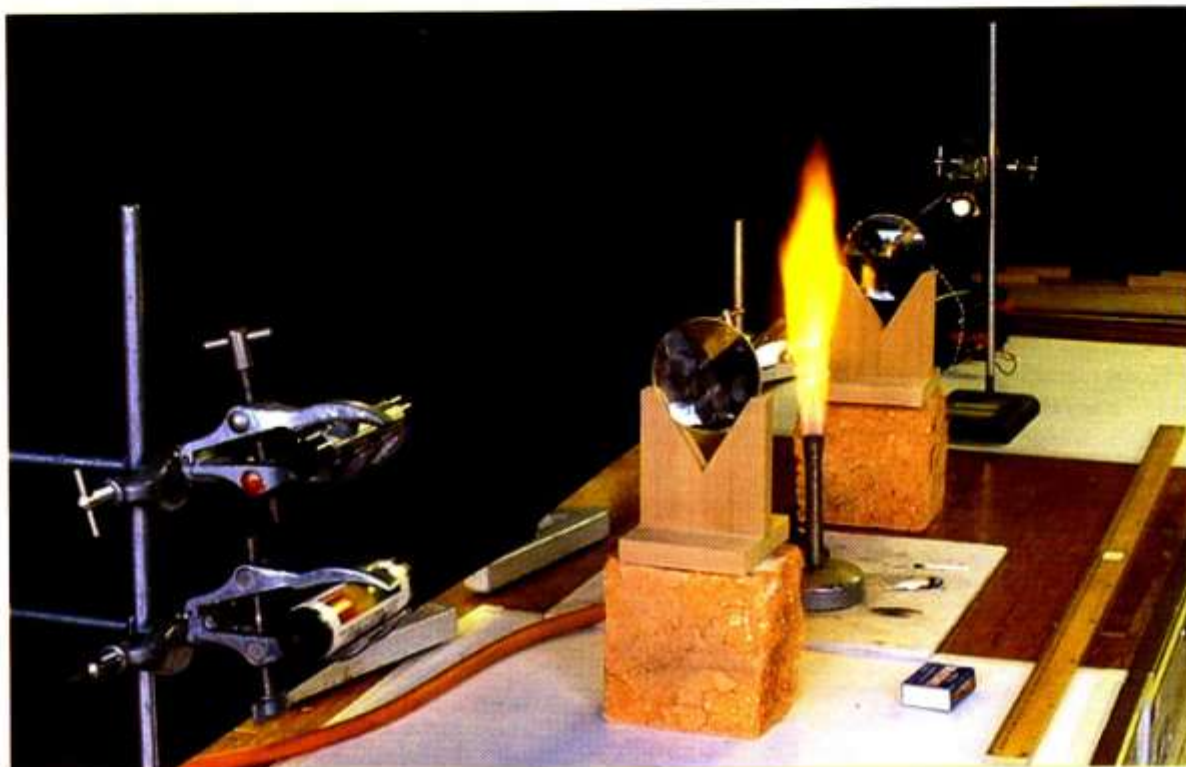

Fig.3 Photograph of the apparatus looking towards the white-light Lumiled. Note how little peripheral light is emitted from the source when the viewpoint lies only a few degrees off axis. The lenses in the photograph have diameters of 75 mm, whereas the ones recommended in the text are 50 mm.



Fig.4 The light must be brought to a focus about 3 – 4 cm above the sodium flame source, which itself must sit a similar distance above the top of the Bunsen. Because the LED is an extended source (rather than a point source), the focused image is also extended.

Risk assessment

As the LED produces intense white radiation, do not look directly at a Luxeon LED from close range (brief close-up viewing is harmless). Do not look for long periods of time at a Luxeon LED source either directly, or with peripheral vision. Ventilate the room to prevent a build-up of hazardous vapours and do the demonstration on a heat-resisting mat.