

SCOTTISH SCHOOLS SCIENCE

EQUIPMENT RESEARCH

CENTRE

Bulletin No.72.

June, 1974.

# Contents

<b>Introduction</b>	- CSYS physics experimental guide	Page 1.
	- adding machines	1.
<b>Physics Notes</b>	- pelican crossing sequence	1.
	- surplus equipment	8.
<b>Chemistry Notes</b>	- combustion of ammonia	10.
<b>Bulletin Supplement</b>	- microscopes	11.
<b>Address List</b>		12.

# Introduction

Concurrently with the previous bulletin, No. 71, we issued an experimental guide to the CSYS physics Memorandum No. 10, Alternating Current, issued by the Scottish Centre for Mathematics, Science and Technical Education. We will in due course issue similar guides to other sections of the CSYS physics syllabus. Because the guide will be of limited interest to teachers of biology and chemistry, we have restricted the issue to one copy per school, addressed to the principal teacher of physics, and we have sometimes omitted to send a copy to schools which we knew, or guessed from their location, would be unlikely to have a sixth year physics group. Also, as the guide is of limited value unless read in conjunction with Memorandum No. 10, we have not sent copies to our subscribers outside Scotland, who would not receive the memorandum. However, they are entitled to receive the guide, and should any wish it, a 'phone call or postcard requesting 'AC experimental guide' will cause it to be sent to them. If they wish a copy of Memorandum No. 10, this can be obtained from the Scottish Centre at 15p per copy (post paid). Cheques or postal orders should be made payable to 'Dundee College of Education'.

\* \* \* \* \*

Many readers will already know of our offer of obsolete adding and tape-printing machines which we have obtained from the Royal Bank of Scotland. Because of the quantity involved and the space taken up by the machines we had to depart from our usual practice of holding the item until we could advertise it in a bulletin. We gave them limited advertising within an area where we thought customers would be prepared to collect the machines from us. There are still a number of these machines in stock, and details are given in the physics notes section of this bulletin.

The bank has been very generous in giving us these machines and although we have thanked them on your behalf, it would be a nice gesture if the satisfied customers could mention the acquisition to their local bank manager, or even write expressing their appreciation to the Assistant General Manager (E.D.P.) at the head office of the bank (Address on page 12). Most of the machines are going to Economics departments in the schools, but we know of one authority which has placed some in their primary schools.

## Physics Notes

In connection with the Memorandum No. 10, alternating current, for CSYS physics, a member of our Development Committee has pointed out that in Fig. 3, p. 4, which is also Fig. 2, p. 2 of our experimental guide, it is not necessary to have a centre tap connection on both the battery and the resistor. Provided that the load resistor across the CRO draws a much smaller current than the

rheostat, the centre tap of the latter will be at the same potential as that of the battery, due to the potential gradient established by current in the rheostat. Hence there is no need to fabricate a U-clamp round the rheostat as described in the experimental guide.

\* \* \* \* \*

There recently appeared in a School Science Review (No. 191, p. 362) details of how to construct a circuit to execute the pelican crossing sequence of traffic lights. Nuffield electronics modules, which are presumably common in English schools, were used, and this will be convenient if the school already possesses these in sufficient quantity. The cost, however, for someone starting from scratch, and referring to the most recent supplier's catalogue amounts to over £60 for the three light sequence alone, i.e. excluding the red and green man signals for the pedestrian. The alternative, which we suggest here, produces a more modest shopping list.

<u>Quantity</u>	<u>Description</u>	<u>Price</u>	<u>Supplier</u>
1	SN7404 Hex Inverter	£0.24	Henry's Radio
2	SN7409 Quad 2-input AND gates	0.66	"
2	SN7432 Quad 2-input OR gates	0.74	"
1	SN7493 4-bit binary counter	0.75	"
1	Type 555 timer	0.95	R.S. Components
5	2N697 transistors	0.75	Henry's Radio
1	Mains transformer, T.S. 18/15*	0.90	"
1	Bridge rectifier B1/05*	0.25	"
1	1000µF, 15V capacitor*	0.12	"
1	BZY88C zener diode*	0.10	"
1	Push-to-make switch	0.10	"
1	On/off toggle switch*	0.15	"
5	MES lamps 6V, 60mA	0.35	"
1	Veroboard strip, 17" x 2½"	0.95	"
5	Lamp holders	0.44	R.S. Components
1 each	4M7Ω, 47kΩ, 22Ω resistors	0.10	"
1 each	0.1µF, 0.22µF capacitors	0.10	"
5	In-line socket strip	2.00	"
		<u>Total £9.65</u>	

The SN74 series of logic units are cheap, compact and as far as we have found, trouble-free. The physical construction of the units is based on a 14 or 16 pin dual-in-line package, which means that the connecting pins are in two rows of 7 or 8 pins each. The pins have a 0.1in spacing and may be soldered directly into Veroboard strip. If this is done it will save the last item of £2 on the shopping list, at the cost of possible trouble later on, should the circuit not work. It is not impossible, but neither

is it easy to unsolder 14 pins simultaneously. Also if one suspects an integrated circuit of being faulty the quickest method of verifying this is to interchange it with a similar one. The components marked \* are associated with a mains power supply, and this expense can be saved if a temporary connection only to batteries can be used. The logic module which provides the necessary sequence of signals requires 5.5V, 140mA, while the lamps and their driving transistors need 9V, 350mA.

For the benefit of those who are unfamiliar with logic circuits, an explanation of the functions of the various units will be given. Some account of Boolean algebra under which these gates function will be found in Bulletin 34 in connection with a Nim playing machine.

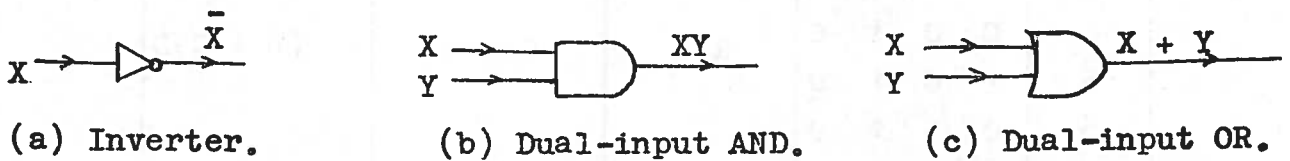

Fig. 1. Logic symbols.

The SN7404 hex inverter contains six inverting gates, represented as in Fig. 1a. As the name implies an inverter inverts whatever input is fed to it, so that if we designate the input as X, its output is 'not X', written  $\bar{X}$ . Six of these are included in the one unit, and are wholly independent of each other in their operation, having only a common power supply.

SN7409 contains four independent dual-input AND gates, with a common supply. An AND gate will give an output only if all its inputs are high so that for a dual input gate, its output is 'X and Y', written XY and symbolised as in Fig. 1b. Similarly the SN7432 has four dual-input OR gates. Such a gate will give an output if either or both of its inputs is high, i.e. output = 'X or Y', written X + Y, Fig. 1c. Truth tables for the AND and OR gates are given in Figs. 2 and 3.

Inputs		Output
X	Y	XY
0	0	0
1	0	0
0	1	0
1	1	1

Fig. 2. Dual-input AND.

Inputs		Output
X	Y	X + Y
0	0	0
1	0	1
0	1	1
1	1	1

Fig. 3. Dual-input OR.

In Fig. 4 we show the truth table of the SN7493 4-bit binary counter. A 'bit' can be loosely interpreted as a power of 2 so that a 4-bit counter counts to  $2^4 = 16$ . What it counts are positive pulses applied to its input. It has four outputs A, B, C, and D, corresponding to  $2^0$ ,  $2^1$ ,  $2^2$ , and  $2^3$ . It is this unit

which is at the heart of the pelican crossing sequence, since one selects various combinations of the four outputs to operate the traffic lights. When the sixteenth pulse is reached all four outputs revert to zero and the count would proceed again if we did not arrange to inhibit it.

Input	Outputs				Vehicle light	Pedestrian light	Function required
	A	B	C	D			
0	0	0	0	0	Green	Red	$\bar{A}\bar{B}\bar{C}\bar{D}$
1	1	0	0	0	Amber	Red	$A\bar{B}\bar{C}\bar{D}$
2	0	1	0	0	Red	Green	$(B + C)\bar{D}$
3	1	1	0	0			
4	0	0	1	0			
5	1	0	1	0			
6	0	1	1	0			
7	1	1	1	0			
8	0	0	0	1	Flashing amber	Flashing green	$A\bar{C}\bar{D}$
9	1	0	0	1			
10	0	1	0	1			
11	1	1	0	1			
12	0	0	1	1	Flashing amber	Red	$ACD$
13	1	0	1	1			
14	0	1	1	1			
15	1	1	1	1			
16	0	0	0	0	Green	Red	$\bar{A}\bar{B}\bar{C}\bar{D}$

Fig. 4. Truth table for logic unit.

In Fig. 4 the pulse sequence which is fed to the binary counter is shown, and we shall refer to the various stages according to the number of the input pulse in the sequence. Stage 0, with all outputs zero is the static or normal condition of the lights, permitting vehicular traffic and inhibiting pedestrians. The sequence is then started by a pedestrian pushing the crossing button. After the sequence is complete the system must revert to stage 0, and hold this until the button is again pressed. The output operating the green vehicle light must be obtainable from stage 0 only, i.e., when  $A = B = C = D = 0$ , which is the function 'not A and not B and not C and not D', or  $\bar{A}\bar{B}\bar{C}\bar{D}$ . For reasons which will be evident later, the way in which this function will be generated is  $A + B + C + D$ . It is left to the reader as an exercise in reasoning, or by use of a truth table to convince himself that these two forms are equivalent, i.e.  $\bar{A}\bar{B}\bar{C}\bar{D} = A + B + C + D$ .

Stage 1 requires the function  $A\bar{B}\bar{C}\bar{D}$ . Stage 2 - 7 is characterised by  $D = 0$  and either  $B$  or  $C = 1$ , hence the output function is

$(B + C)\bar{D}$ . In stages 8 - 15 we need to generate a flashing signal which means that the A output, which changes with every pulse, is used, so that for stage 8 - 11 the function is  $A\bar{C}\bar{D}$  and for 12 - 15 it is  $ACD$ .

Taking first the vehicle lights, green is generated by  $A + B + C + D$ . The amber light is needed at stage 1, with flashing amber at stages 8 - 15. Hence the function for the amber light is  $A\bar{B}\bar{C}\bar{D} + A\bar{C}\bar{D} + ACD$ , which will simplify to  $AD + A(B + C)$ . The first part of this expression gives the flashing signal in stages 8 - 15 and the second part gives stage 1. The red vehicle light, from stage 2 - 7, is given by  $(B + C)\bar{D}$ . The red pedestrian light is needed in stages 0 - 1 and 12 - 15. In 12 - 15 the red must be on continuously, not flashing, so that the function is  $CD$ . The whole function for the red light is  $\bar{A}\bar{B}\bar{C}\bar{D} + A\bar{B}\bar{C}\bar{D} + CD$ , which simplifies to  $CD + (B + C + D)$ . The green pedestrian light is required at stages 2 - 11, flashing from stages 8 - 11, and the whole function for this is  $(B + C)\bar{D} + A\bar{C}\bar{D}$ . Fig. 5 summarises these results.

Light	Stages	Function
Red vehicle	2 - 7	$(B + C)\bar{D}$
Amber vehicle	1, 8 - 15	$AD + A(B + C)$
Green vehicle	0	$(A + B + C + D)$
Red pedestrian	0 - 1, 12 - 15	$CD + (B + C + D)$
Green pedestrian	2 - 11	$(B + C)\bar{D} + A\bar{C}\bar{D}$

Fig. 5.

An examination of Fig. 5 will show why it is more convenient to use OR rather than AND functions in some cases, e.g. to generate  $(B + C + D)$  rather than its equivalent  $\bar{B}\bar{C}\bar{D}$ . The  $(B + C)$  function occurs in all five wanted functions in some form, and having generated it through a dual-input OR gate, it can be directed to all five signals. The SN74 series of integrated circuits normally have a 'fan out' capacity of 10, which means that an output can be used to drive up to 10 inputs to other similar circuits without overloading it.

Fig. 6 shows the complete function diagram for the unit. The timer (see Fig. 7) produces short negative pulses at a frequency of about 1Hz. If it is desired to speed things up, the repetition time can be reduced by reducing the value of the 4M7Ω resistor and 0.22μF capacitor. The pulse repetition frequency is proportional to the time constant CR of these two components. The timer output is inverted and applied to an AND gate which feeds the counter. The counting sequence therefore will not start until the other input to the AND gate is made high, which is done through the push-button switch. The +V to which this switch is connected should be the 5.5V supply of all the logic circuits. To hold this input high after the pedestrian has released the switch we also supply it with the function  $(A + B + C + D)$ , which will revert to zero at stage 16, thus resetting the circuit.

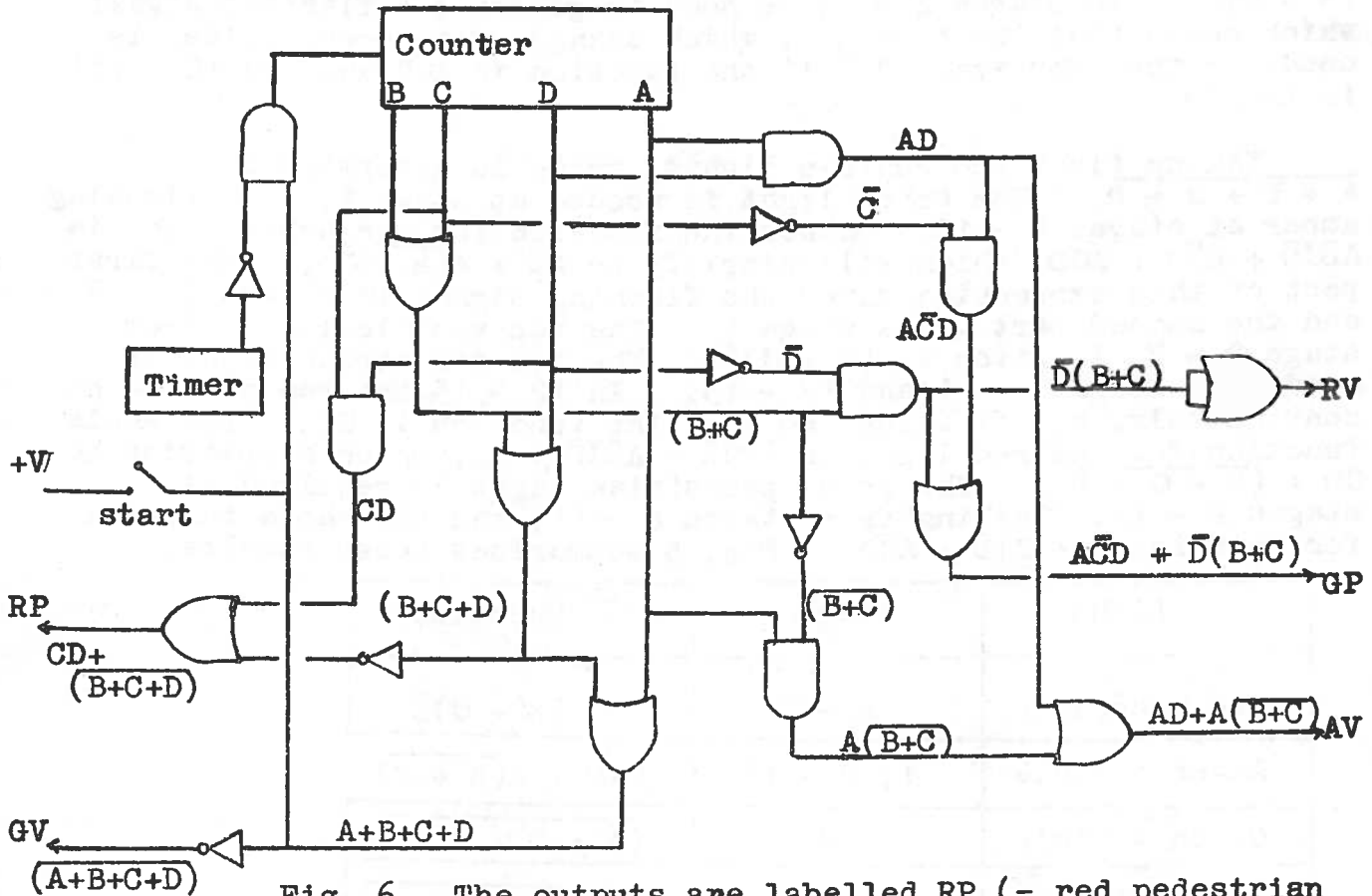

Fig. 6. The outputs are labelled RP (= red pedestrian light) etc.

This arrangement for initiating the sequence works well enough, although it means that the pedestrian must hold the push button until the first pulse from the timer has gone through, which may be up to one second. It is possible, and fairly simple, to include a pulse-lengthening device between the switch and the AND gate, but this means another integrated circuit - SN74121 monostable multivibrator - and consequently greater expense.

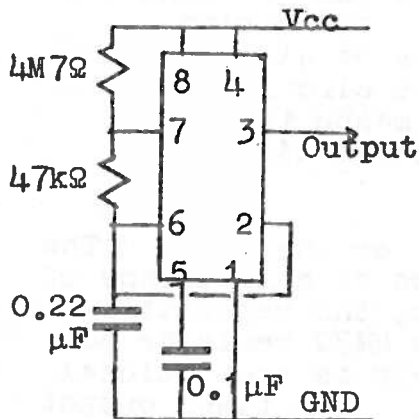

Fig. 7. Type 555 timer connections.

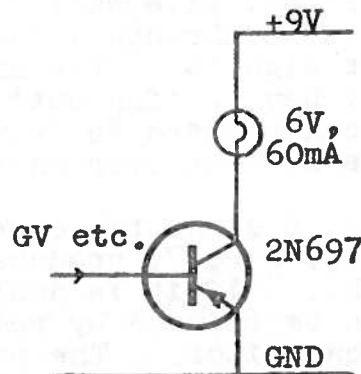

Fig. 8.

Inspection of Fig. 6 shows that the circuit requires six inverters (one SN7404), six dual-input AND gates (two SN7409, with two gates to spare), and seven dual-input OR gates (two SN7432). One part of the diagram may require explanation - the final OR gate on the red vehicle signal. This has the purpose of isolating the  $(B + C)\bar{D}$  signal, which is also an input to the final OR gate of the GP chain, from the driving transistor for the RV light. We found that if an output from a logic gate were used as



in Fig 8 to drive the base of the 2N697 transistor it did not become sufficiently positive to act as an input to further gates.

Wiring up the circuit is more painstaking than difficult. The layout of components, and the choice of which gate for which particular function, are left to the constructor, but should be decided with a view to keeping the connections as short as possible. We think it essential to draw out the complete wiring diagram on graph paper full size or larger. Different coloured inks will help to preserve clarity. As the wiring diagram is being made, each connection on the function diagram of Fig. 6 should be ticked off. The same procedure is then used in constructing the unit from the diagram.

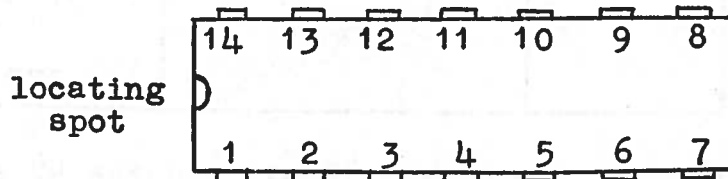

14 pin dual-in-line package; top view.

Pin No.	SN7404	SN7409	SN7432	SN7493
1	1X	1X	1X	Y *
2	10	1Y	1Y	GND
3	2X	10	10	GND
4	20	2X	2X	-
5	3X	2Y	2Y	Vcc
6	30	20	20	-
7	GND	GND	GND	-
8	40	30	30	C
9	4X	3X	3X	B
10	50	3Y	3Y	GND
11	5X	40	40	D
12	60	4X	4X	A
13	6X	4Y	4Y	-
14	Vcc	Vcc	Vcc	X

Fig. 9. Pin connection to integrated circuits. \*This pin requires to be connected to output A, pin 12.

The table of Fig. 9 above gives the pin connections to the integrated circuits. The inputs are designated X and Y, preceded by a number to indicate the particular gate. The outputs are designated O, except for the 4-bit counter, where they are labelled A, B, C, and D in accordance with Fig. 6. GND denotes zero volts, and Vcc is the positive terminal of the dc supply, and should be  $5 \pm 0.5V$ . It is emphasised that the numbering of the pin

connections is a top view of the package and not on the pins themselves. On the counter, pin 10 is the ground connection; pins 2 and 3 are re-set inputs which are grounded for this application. Pins marked - have no connection and can be left unconnected. Input to the counter is at X, pin 14.

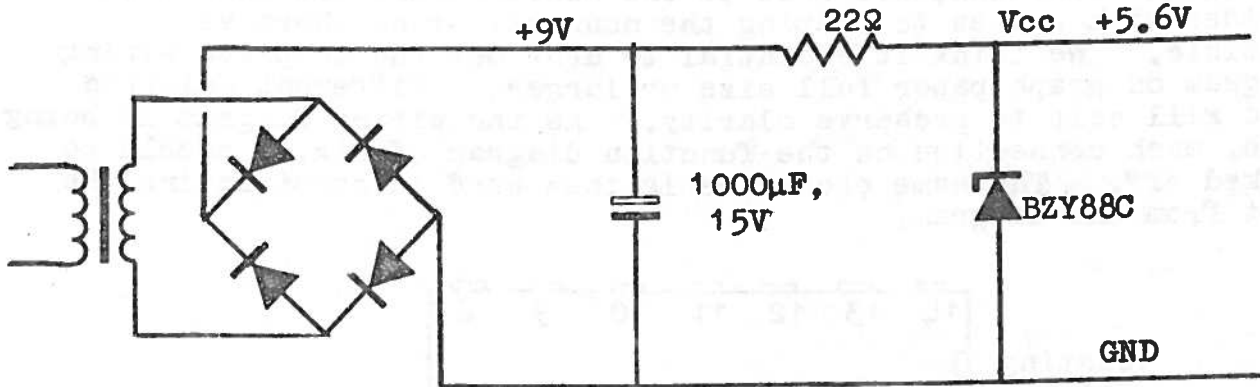

The power supply, Fig. 10, is conventional, and the 9V supply is nominal value only, anything which gives sufficient brightness for the lamps being adequate. The zener stabilised supply drives the logic circuits. No account has been taken here of the need to fit components into a box, or to mount the lamps in a suitable stand. In fact if the intention is to give a pupil the satisfaction of devising and testing the sequence the lamps and their driving transistors can be omitted and the results tested by using voltmeters across the outputs of the logic circuit.

\* \* \* \* \*

The following items of surplus equipment are still available, and from Item 434 onwards we give details of items not previously listed.

- Item 369. (67) Kodak stabiliser, 10p.
- Item 370. (67) Borax powder, 10p.
- Item 371. (67) Motors, £1 - £2.
- Item 375. (67) Wire recorder, £5.
- Item 378. (67) Radiator thermostat, 5p.
- Item 379. (67) Tuning fork, 50p.
- Item 381. (67) Heating elements, 5p.
- Item 383. (67) Pre-set potentiometer, 10p.
- Item 384. (67) Mixed value resistors, 5p.
- Item 385. (67) Mixed value resistors, 10p.
- Item 387. (67) Filter paper, 50p.
- Item 390. (67) NiFe battery, 60p.
- Item 396. (67) Fluorescent lamp shades, 10p.
- Item 398. (67) Psychrometer, £2.
- Item 400. (67) Maltese cross tube, £6.
- Item 402. (67) Deflection e/m tube, £9.

- Item 411. (69) Asbestos sheet, 5p.
- Item 412. (69) Asbestos sheet, 40p.
- Item 413. (69) Nickel cadmium battery, £1.
- Item 417. (69) Fan units, £1 - £5.
- Item 418. (69) Nasal spray, 30p.
- Item 420. (69) Petri dish, 20p.
- Item 421. (69) Rubber balls, 40p.
- Item 422. (69) Power supply, £5.
- Item 423. (69) Power supply, £5.
- Item 424. (69) Power unit, 20p.
- Item 425. (69) Logic unit, £5.
- Item 426. (69) Logic unit, £3.
- Item 427. (69) Receiver drive unit, £3.
- Item 428. (69) Transmitter drive unit, £3.
- Item 429. (69) Logic unit, £2.
- Item 430. (69) Data receiver, £1.
- Item 431. (69) Data transmitter, 50p.
- Item 432. (69) Control unit, 20p.
- Item 433. (69) Heavy duty switch, 10p.
- Item 434. Pipettes, 1cm<sup>3</sup> and 3cm<sup>3</sup>, type PM-106 by Gallenkamp; both types, 10p.
- Item 435. Darkroom safelight, type NX914 by Ilford. Plane 5" x 7", sepia, for use with X-ray film and blue sensitive fluorographic materials, 20p.
- Item 436. Developer, type ID-57 by Ilford, 1 litre, to make 1½ litres working solution, 10p.
- Item 437. Fixer, type IF-18 by Ilford, 1 litre, to make 1½ litres working solution, 10p.
- Item 438. Linagraph direct print paper, by Kodak, 15cm x 45m roll. This is described as being designed for producing visible traces in oscillograph recording equipment having u.v. or high-intensity light sources, and has a writing speed in excess of 30,000 inches per second with a high-pressure mercury lamp. Per roll, 50p.
- Item 439. Monochrome film, type TXP 220 by Kodak, ASA 400, 120 size spool, 10p.
- Item 440. Amfix rapid fixer with hardener, to make 5 litres working solution, 20p.
- Item 441. Dc milliammeter, 100mA, 66Ω movement, scale radius 75mm, £1.50.
- Item 442. Decade counter, type D657 by Panax; contains 6 decaatron tubes and counts correctly on internally generated signal, but not so far on an external signal. £5.
- Item 443. Adding machine by Burroughs, £sd type, capacity £10M - 1d. £1.

- Item 444. Adding machine, type TR31en by National Cash Register, decimal, capacity £10M - 1p. The machine carriage can be set to give horizontal or vertical print-out, and also has a window showing the running total. Subtractions are printed in red; totals and sub-totals can be printed. With transformer to convert from 240V to 110V, £2.
- Item 445. Tape writing machine, by N.C.R. This couples into the adding machine above, item 444, and prints in binary coded decimal on punched tape any entries or totals made on the adding machine. £1.
- Item 446. Tape recorder, by Grundig; no microphone, and amplifier known to be faulty, £1.
- Item 447. Punched card clock, as used on the factory floor for clocking in and out; in working order. First reasonable offer secures, and no questions asked as to its application in the classroom.
- Item 448. Banda spirit duplicator, in working order, £5.
- Item 449. Combined vacuum/pressure pump, type MU 19/75SE by Charles Austen, producing a pressure difference of approx.  $\frac{2}{3}$  atmosphere, 240V mains operation. The motor is fitted with reduction gearbox and pulley for belt drive. £5.
- Item 450. Ballraces, various, but mainly of two types viz. inside diameter  $\frac{1}{2}$ " or  $\frac{5}{8}$ "; outside diameter  $1 \frac{1}{8}$ " or  $1 \frac{3}{8}$ ", both types, 5p.
- Item 451. Nylon gears, various, 5p.

## Chemistry Notes

Generally text-books state that ammonia will not burn in air, but it has been pointed out by St. George's School for Girls, Edinburgh, that it can be made to burn. It is well known that when a taper is put to ammonia gas there is slight burning in the immediate space near the flame. If sufficient air is mixed with the gas, e.g. by passing ammonia into an inverted gas jar for a short time the mixture burns with a brown flame when a lighted taper is inserted. The flame is not very strong but it is quite distinct. We were able to burn the gas in this way many times, showing that the ammonia/air proportion is not very critical.

In 'A Modern Approach to Chemistry', Stove and Phillips, the authors state 'If a burning taper is thrust into a jar of ammonia the taper goes out and the gas does not burn. However if the taper is slowly lowered into ammonia a brief flash of brown flame can usually be seen. This suggests that the ammonia/air mixture at the top of the jar burns freely'.

## Bulletin Supplement

The instruments listed on this page have been tested according to our published procedures for 'O' grade microscopes. Individual, fuller reports on each model can be borrowed for up to one month by writing to the Director. The classifications used are: A - most suitable for school use; B - satisfactory; C - unsatisfactory.

Model	Tecnar	Monolynx B	CD610
Manufacturer	Swift	Gillett and Sibert	C and D Scientific Instruments
Supplier	Pyser-Britex	"	"
Price	£24.80*	£25.00	£36.00
Eyepiece	10x, widefield or Huygenian	Widefield type	10x, Huygenian
Objectives	4x, 10x, 20x, non-standard	Inapplicable, magnification by changing eyepiece tubes 60x, 100x, 140x, 175x	4x, 10x, 20x
Optical head	Upright	Inclined	Upright
Condenser	None	None	Fixed lens in stage
Aperture control	Rotating disc	None	Iris diaphragm
Smoke cell accommodation	4x objective only	With great difficulty	Yes
Illumination	Mirror only	Built-in, low voltage	Mains illuminator
Assessment	A	C	C

Notes. \*This price is for widefield eyepiece; with Huygenian eyepiece the cost is £23.00.

The Monolynx B is of an unusual 'inverted' design, with light passing downward through slide and objective, then by reflection at a mirror to the eyepiece tube. The C assessment was given because of difficulties of use and an unsatisfactory optical performance.

The CD610 was given a C assessment because of unsatisfactory optical performance.

S.S.S.E.R.C., 103 Broughton Street, Edinburgh, EH1 3RZ.  
Tel. 031 556 2184.

Charles Austen Ltd., Petersham Works, 100 Royston Road, Byfleet,  
Surrey.

(Banda) Block and Anderson Ltd., Banda House, Cambridge Grove,  
Hammersmith, London W6 0LE.

Burroughs Machines Ltd., Heathrow House, Bath Road, Cranford,  
Hounslow, Middlesex.

C and D (Scientific Instruments) Ltd., 439a London Road,  
Hemel Hempstead, Herts.

A. Gallenkamp and Co. Ltd., Technico House, Christopher Street,  
London, E.C.2.

Gillett and Sibert Ltd., Lynx House, 50 Vicarage Crescent, Battersea,  
London, S.W.11.

Grundig (G.B.) Ltd., Newlands Park, Sydenham, London, S.E.26.

Henry's Radio Ltd., 303 Edgware Road, London, W2 1BW.

Ilford Ltd., Ilford, Essex.

Kodak Ltd., P.O. Box 66, Kodak House, Station Road, Hemel Hempstead,  
Herts.

National Cash Register Co. Ltd., 206/216 Marylebone Road, London, N.W.1.

Panax Equipment Ltd., Holmethorpe Industrial Estate, Redhill, Surrey.

Pyser-Britex Ltd., Fircroft Way, Edenbridge, Kent, TN8 6HE.

R. S. Components Ltd., P.O. Box 427, 13-17 Epworth Street,  
London EC2P 2HA.

Royal Bank of Scotland, 42 St. Andrew's Square, Edinburgh, EH2 2AD.

Scottish Centre for Mathematics, Science and Technical Education,  
College of Education, Park Place, Dundee, DD1 4HP.