

**SCOTTISH SCHOOLS SCIENCE  
EQUIPMENT RESEARCH CENTRE**

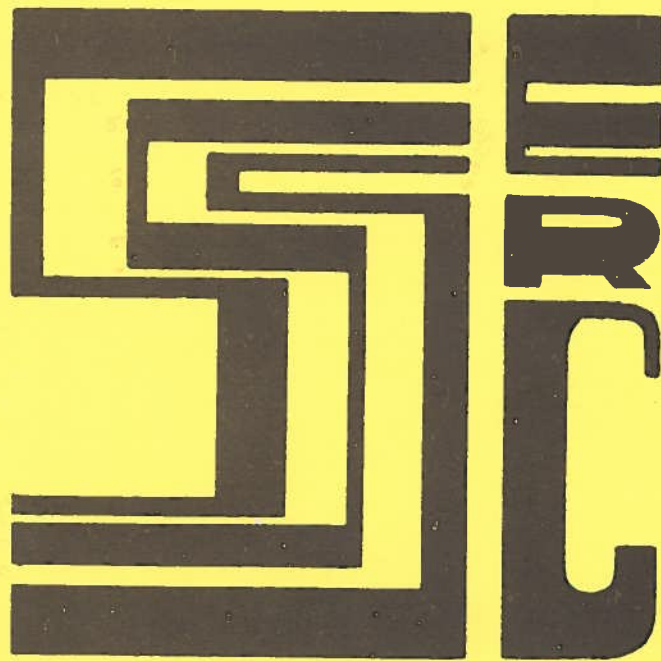

Bulletin No134

February, 1983

## ADDRESS LIST

- SSSERC, 103 Broughton Street, Edinburgh EH1 3RZ. Tel. 031-556-2184.
- Artec (I for E) Ltd., Salewheel House, Ribchester, Preston, Lancs. PR3 3XU. (0254) 84215.
- Cambion Electronics Products, Cambion Works, Castleton S30 2WR. (0433) 2081.
- Climpex Ltd., Hammers Lane, Mill Hill, London NW7 4DY. (01 959) 1060.
- J.E. Cockayne, 6 Birkmyre Road, Govan, Glasgow. (041 440) 1010.
- George Cook (Electronic Instruments), 21 Manor Road, Knaresborough, N. Yorks HG5 OBN. (0423) 862641.
- Economats Educational Division, 4 Orgreave Crescent, Dore House Industrial Estate, Handsworth, Sheffield S13 9NQ. (0742) 690801.
- Educational Electronics, 7 Wood Street, Woburn Sands, Milton Keynes MK17 8PH. (0908) 584134.
- Ergon Structures Ltd., Chapel Place, Fisherton Street, Salisbury, Wilts. SP2 7RJ. (0722) 5243.
- Flow Laboratories Ltd., P.O. Box 17, Second Avenue Industrial Estate, Irvine, KA12 8NB. (0294) 74242.
- G. Gallagher, Longman Micro Software, 33-35 Tanner Row, York.
- Griffin and George Ltd., Ledson Road, Wythenshawe, Manchester, M23 9NP. (041 248) 5680.
- Hampshire Micro, 57 New Market Square, Basingstoke, Hampshire, RG21 1HW. (0256) 62871.
- Philip Harris Ltd., 34-36 Strathmore House, Town Centre, East Kilbride, G74 1LQ. (03552) 34983/4.
- Philip Harris Biological Ltd., Oldmixon, Weston-super-Mare, Avon. (0934) 413063.
- Horwell Ltd., 2 Grangeway, Kilburn High Road, London, NW6 2BP. (01 328) 1551.
- Irwin-Desman Ltd., 294 Purley Way, Croydon, Surrey, CR9 4QL. (01 686) 6441.
- Johnson Matthey Chemicals Ltd., Orchard Road, Royson, Herts SG8 5HE. (0763) 44161.
- Limrose Electronics Ltd., Aerial Road, Llay Industrial Estate, Wrexham LL12 OTU. (097 883) 5555.
- A.M. Lock and Co. Ltd., (Locktronics), Neville Street, Oldham, Lancs. OL9 6LF. (061 624) 0333.
- J.R. Moore, 95 Swann Lane, Cheadle Hulme, Cheadle SK8 7HU. (061 485) 5654.
- Oakes Eddon and Co., Scientific House, Dryden Street, Liverpool L5 5HH. (051 207) 3062.
- Oertling Ltd., Cray Valley Works, St. Mary Cray, Orpington, Kent BR5 2HA. (0689) 25771.
- Prior Scientific Instruments Ltd., London Road, Bishop's Stortford, Herts CM23 5NB. (2079) 506414.
- Pyser Ltd., Fircroft Way, Edenbridge, Kent TN8 6HA. (0732) 864111.
- Science and Technology Education on Merseyside Ltd., (STEM), STEM Walton Unit, 65 Walton Lane, Liverpool L4 4HG. (051 207) 1869.
- Unilab, Clarendon Road, Blackburn, Lancs.
- Weir Electrical Instrument Co. Ltd., Bradford on Avon, Wiltshire BA15 1BU. (02216) 2043. .
- White Electrical Instrument Co. Ltd., Spring Lane North, Malvern Link, Worcs. WR14 1BL. (06845) 3218.

# INTRODUCTION

## ASE Annual Meetings

This bulletin is being edited immediately after my return from the Association for Science Education 1983 annual meeting in Manchester. The parent body meeting is such an important landmark in the science education year it is perhaps inevitable that this edition of our bulletin should be coloured by it. For example the 'Trade News' section is devoted to a report on the manufacturers' exhibition, for as well as being a conference the meeting is also the premier 'trade fair' for U.K. school science education.

The 1983 meeting proved to be particularly stimulating (and not just on the social side). A number of central issues in science education seemed to have come to the boil and several ideas which have been sub-surface for a while, seemed again to be meeting their time and were on everyone's lips. These issues included technology (bio- and microelectronic) in school curricula, primary science, the social aspects of science education and 'science and technology for all'. However, as one very experienced Scottish adviser pointed out to us, "Some folk seem to think that a problem is solved just by talking about it". He was right, of course. A few of these issues have been around for a long, long, time. Merely because another cycle of consensus is with us, in itself means nothing unless the talking leads to action.

The other pleasant aspect of the meeting was the largest Scottish contingent seen for some time. I know that the uncivilised Sassenachs are mostly to blame for the situation. After all, who else would arrange a major conference just after Hogmanay? At the same time it was embarrassing at Canterbury in 1982 for the Scots to be heavily outnumbered by the Norwegians. The better attendance in 1983 was put down by most to the relative ease of reaching Manchester. Even so, many of those from Scotland were like myself "ivory tower men", "refugees from the chalk-face" whatever term of abuse real teachers like to apply. Actual Scots teachers were thin on the ground. The numbers were increased, the Scottish Region ASE having, I think, run a sort of raffle and provided some subsidised places. Lack of money cannot be the only reason for lack of attendance. At least one Scots adviser confided that he thought the meeting so important that for any serious teacher applicants in his region the money would somehow be found. However, how many Scots we will see in Exeter in 1984 is still problematical.

The Scottish Region Annual Meeting is to be held in Jordanhill College this year and reasons for any poor attendance figures will not be so easily identified. The meeting will run from the 6th to 8th of April inclusive.

SSSERC will be there, as always, running an exhibition, an electronics/micro-electronics/interfacing workshop and selling some surplus equipment.

Finally, for the super politically-minded of our readers, I should perhaps point out that despite all that propaganda for ASE we are independent organisations!

## Cost Index

In describing in 'Trade News' all the new equipment goodies on show at the ASE in Manchester we were very conscious also of the dearth of money to buy any of them. Many Principal Teachers, we know, are struggling to buy consumables never mind raising the steam for capital items. So, now for the good news!

For the six months to November 1982 the index hardly moved. The SSSERC cost index for consumable science materials is sampled twice yearly in May and again in November. In May 1974 the baseline was set at 100. In November 1982 it stood at 310.4. In cash terms - in May 1974 the basket contents cost £192.69 ( $\cong$  100) in November they were £598.08. Calculation of the percentage increase since November 1982 gives an annual figure of approximately 5% (4.86). However even better news is that the downward trend in the rate of increase, announced in Bulletin 132, has been maintained. The calculation for the six monthly period May to November 1982 gives a figure of less than 1% (0.94).

## Money, money, money!

It is almost again that time of year which every Principal Teacher dreads. The requisition season is upon us. Inevitably, with yet more talk of 'cuts', we will be accused by some of having a sick sense of humour in publishing some of the material in the issue. We make no apology for the very full "Trade News" pages. In some areas at least, science equipment is undergoing some exciting developments. We have a duty to provide as much relevant information on this new apparatus as we can. This is so even if, as some would claim, we seem to rub salt into the wounds of science education.

Some items in the "Biology" and "Chemistry Notes" are more concerned with possible saving of money rather than its spending. We hope this may partly redress the balance. More emphasis on "real" (ie. d-i-y) science is promised for the next issue.

★ ★ ★ ★

## Opinion

MacDiarmid's list of subjects on which a lot of "rubbish" is spoken is: Burns, Liberty and Christ.

"Mair nonsense has been uttered in his name (Burns).  
Than in ony's barrin' Liberty and Christ.'"(1)

Orwell's list is longer.

"Other words used in variable meanings, in most cases more or less dishonestly, are: class, totalitarian, science, progressive, reactionary, bourgeois, equality." (2)

Orwell went on to describe the list as "this catalogue of swindles and perversions". We are intrigued by his inclusion of the word "science", and we have asked ourselves to what extent its usage, as the title of that third of the core curriculum, is a swindle and perversion.

We turned to the Association for Science Education to look for an authoritative opinion on what happens in school science. A recent article in the SSR tells us that

"... the object of science is to understand the phenomena of the natural world. In teaching science our main object is to bring children to a state of mind in which they understand some of the classic and recent phenomena which scientists have explained... The 'point' of the explanation is that they enable us to understand the natural world in which we live". (3)

This perceptive statement suggests that school science is about science rather than being science. It is here that the swindle and perversion occur, because science is scarcely practised in schools. There is little time for practice; the syllabuses are choc-a-bloc with accounts of scientific theories (even, for shame, at first year level!). The children sense the deceit. We let them down.

If we probe into the idea that "the object of science is to understand the phenomena of the natural world", we should expect to find encouragement for qualities of the following sort in school science: not accepting anything at its face-value, keeping an open mind, inquisitiveness, an expression of wonder and marvel, being prepared to put ideas to the test, honesty, keenness of observations, aesthetic enjoyment.

These qualities are written in as objectives to our science syllabuses and many teachers will maintain that

their science lessons are based on these qualities. It is sad that we, the science teaching profession delude ourselves in the manner of the crowd who cheered the emperor in his new clothes. These qualities are supposed to be there. We think they are there, but in fact often they are not. The schooling process may kill off the very thing it sets out to achieve. Science is in occultation behind schooling.

It is even sadder to realise that children acquire these qualities by themselves, only to have them snuffed out by unsympathetic schooling. A point always worth remembering by teachers is that very young children teach themselves to talk. Children acquire at an early age a sense of inquisitiveness, keenness of observation, and a preparedness to put ideas to the test. It is iniquitous that by the end of S2 many children have switched off from 'science' because their schooling did not make use of, or even wrecked these qualities.

The irony of the position of school science is that it would appear that better science may be being taught in primary schools (the few that care to teach it) by non-science graduates, than is being taught in secondary schools with an all graduate profession. This crazy state of affairs it does exist, and it seems to some extent that it does, has perhaps come about because the primary teacher has to use his own native wit to work out for himself what science should be all about. The secondary teacher follows the weary path of professional wisdom.

There should we think be two distinct types of science course in secondary schools. There should be courses about science and there should be courses on doing science. The "about science" courses would be for the few at Credit and Higher grade. The "doing science" courses would be for the masses in S1/S2, Foundation and General.

Far better, we think, for the secondary schools to learn from good primary practice, than that the sins of the former be visited on all of the children.

### References

- (1) MacDiarmid, H., "A Drunk Man Looks at the Thistle".
- (2) Orwell, G., "Politics and the English Language", Horizon.
- (3) Ormell, C., "Mathematical models and understanding in Science", S.S.R., 1980, 219, 62, 375-81.

★ ★ ★ ★

## Biology Notes

### Re-usable plastic Petri dishes

There have been claims in the literature from time to time that disposable polystyrene Petri dishes could be recycled by chemical 'sterilisation'. In our view, these claims did not stand up to scrutiny because of the doubtful microbiological techniques used to monitor sterility. However a recent breakthrough has now made recycling possible not by chemical means but by autoclaving.

Some biology teachers, obviously good conservationists, have always been uneasy about 'throw away' technology. Some have even returned to using glass Petri dishes. Given the high initial outlay and serious risk of heavy losses through breakages, a decision to go for glass is certainly a brave commitment to one's ecological principles. Now recyclable polycarbonate dishes have hit the market and may offer an attractive compromise.

The 'Titertek' polycarbonate dishes we have tested were submitted as samples by **Flow Laboratories Ltd.** The dishes, it was claimed, were designed to withstand autoclaving at 121°C. Our samples were the usual 90mm diameter type used in most schools. Cost comparisons for these dishes and the same approximate sizes in disposable polystyrene and glass are given in Table 1

It is interesting to apply 'milk bottle' economics to the figures in Table 1. It will be seen that to be ahead of the game in recycling glass dishes rather than using plastic disposables, each glass dish must, on average, make at least 13 journeys (tempting fate?) if one buys disposables in bulk. With disposables bought in smaller quantity the break even point is about 7 journeys. (The superstitious could go to town here. It is obviously inadvisable to take Petri dishes under ladders!).

With reusable polycarbonate dishes against disposables, bulk buying both, the break even point is about 7 journeys. With more expensive small quantity buying of the disposables this drops to 5 journeys.

Therefore everything hinges on the odds against making the required number of journeys. Here glass dishes are at some disadvantage being prone to breakages. We found however that we could drop polycarbonate dishes from great heights, or even stand on them, without any breakages occurring. On the other hand we know that resistance glass will stand any number of autoclave cycles at 121°C (at 15lb<sup>-2</sup> or

Type of dish and material (all 90 or 95mm dia. of one	Source and pack size	Price per pack	Price per dish
Disposable polystyrene	Harris pack of 10	78p	7.8p
	Griffin pack of 20	£1.45p	7.25p
	Sterilin, Bulk, case of 500(x10s)	£22.70	ca. 4.5p
Re-usable glass	Harris pack of 10	£5.89	ca. 59p
	Griffin pack of 72	£37.93	ca. 53p
Re-usable polycarbonate	Flow Laboratories Pack of 60(x10)	£19.50	32.5p
	Harris Pack of 60(x10)	£26.52	44.2p

TABLE 1

103kNm above atmospheric pressure). The polycarbonate dishes were claimed to withstand steam at 121°C but we didn't know how many times they would go through the normal warm up, 15 minutes steam and cooling cycles. We therefore carried out some crude tests.

Four dishes were tested as shown in Table 2 'over'.

These tests are obviously very artificial and certainly lack rigour. However the results, particularly with dish 2, encourage us to run more extensive trials involving actual school use. There are a number of possible snags with polycarbonate dishes which would only be elucidated by school trials. For example, will 'scuffing' of the surfaces make the dishes unacceptably opaque after a while? Also, the makers warn against autoclaving with any volatile stains which will discolour the dishes or with other more thermo-degradable plastics which will melt on to the dishes and bond with

## Chemistry Notes

Dishes (All 'empty')	Treatment	Result
	Normal warm up and cooling plus:	
1	15 minutes in an autoclavable disposal bag on trivet of 'Prestige 'Hi-dome'.	No significant discolouration nor permanent distortion observed.
2	15 minutes on trivet as above, no bag. Followed by a further 6 such cycles - ie. 7 cycles in all.	" "
3	30 minutes uninterrupted steaming at 121 °C in bag as 1	" "
4	30 minutes uninterrupted steaming at 121 °C on trivet, no bag, as 2 but one 30 minute cycle only.	" "

TABLE 2

them. Heavy objects placed on the dishes during autoclaving will lead to permanent distortion.

Is anybody out there looking for a school 'consumer science' project? (P.S. we would supply the samples).

### Review

We have just received a copy of "Techniques in Biological Field Work - A Manual for Teachers". Written by Paul Mills and published by Aberdeen College of Education Department of Biology, this is an excellent, compact, source book for teachers. It is full of practical ideas and useful references. We would recommend it to all teachers with an interest in biology fieldwork. At a £1 a copy it won't bankrupt you either! Details of other Aberdeen College Biology publications are to be found on the inside back cover of this bulletin.

★ ★ ★ ★

### Electron direction indicator (EDI)

One topic long known as a source of difficulties for pupils is that of oxidation and reduction, especially in cell reactions. Many methods, tricks (eg. "OILRIG") and analogues have been used in attempts to remove or circumvent these difficulties. They have met with varying degrees of success. The small device described here was shown to us as a prototype some time ago. Since then the originators, Dr. Alistair Wham and Mr. Hamish Storrie (both of Boclair Academy), have developed the idea further into a device which seems to us an excellent aid to pupil understanding.

Whilst the circuitry we describe is a modified form of the original Boclair device, its overall operation and its use by pupils has not changed. All the credit for the original idea and, to use the jargon, the 'pedagogical' aspects of the device must go to Messrs. Wham and Storrie. We understand that a longer article on the EDI is due to appear in the June 1983 issue of the School Science Review. It is in order that we may reach a wider audience in Scotland that we have published, with permission, a shorter description here.

The electron direction indicator tells a pupil directly at which electrodes oxidation and reduction are occurring and also shows the direction of electron flow. The pupil simply connects his redox reaction cell to the two input sockets on the device. Two leads, with crocodile clips at the electrodes at the cell end and two 4mm plugs at the EDI sockets are used. Two white, or other matched leads of any colour lacking connotations of polarity are best for this purpose.

When so connected and switched on, one of the l.e.d.'s on the device will light showing the direction of electron flow and which of the two processes is occurring at each electrode (see Fig.1 below).

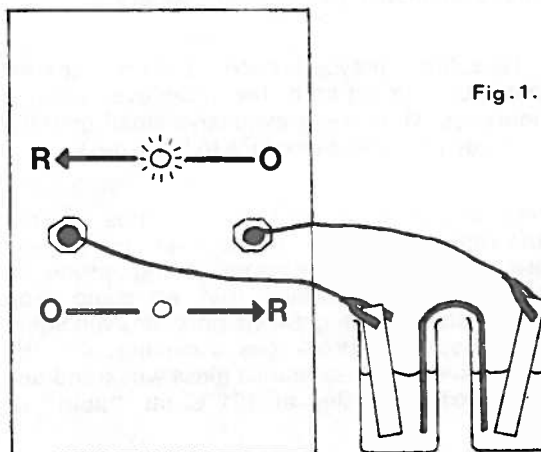

Fig. 1.

The device has several advantages over the use of a conventional voltmeter:

- There are no 'polarity' problems.
- It is thus more robust and will always give a 'correct' answer first time.
- There is less confusion and 'noise' in the experiment. Pupils do not have to translate from the 'positive current' as shown on a meter to actual electron flow. (However this advantage can also be gained by using a conventional, but centre zero, meter with reversed connections to the terminals and a labelled mask on the dial).
- The circuit is relatively inexpensive, and easily constructed.
- Potential differences are readily detected for the whole range of usual cells with this one device.

potential divider is to ensure that the non-inverting input to the op amp is 0V when probe X is floating. Otherwise stray signals such as mains noise would be amplified and drive the display i.e.d.'s.

The 10k pot should be a preset boxed within the instrument so that pupils do not have access to it. After constructing the circuit the pot should be adjusted once and for all so that both D1 and D2 are off when probe X is floating. Should the adjustment not prove to work check that the dual supply potentials are evenly balanced and check that the two 100k resistors match.

The device should detect a potential difference across the probes which is greater than 20mV. The current drawn by the device is very small.

Our circuit was made up in a proprietary aluminium case which also housed the two PP6 batteries required to drive it. Obviously other case materials could be used. On balance we would recommend some type of metal box to minimise 'pick up' of any extraneous noise.

#### Chemicals costs

In the case of some chemicals the costs from different suppliers are often remarkably similar, but other chemicals sell for more widely different prices. On average the global sum of a shopping list may be fairly similar regardless of supplier. Unless such differences are large or consistently in favour of one supplier it may not seem worthwhile making out the annual requisition with five or six catalogues around you. Time so spent will certainly be unproductive if the handling and/or delivery charges requiring to be paid to several different suppliers eat up any gains made. So long as not more than two suppliers are used, the total orders for each will certainly be sufficiently large to qualify for any free delivery or waiver of handling charge terms. Nevertheless the example given below shows that the prices from one supplier may be consistently about two thirds less than of those of another.

**Johnson Matthey Chemicals**, who provided one of the cheaper sources of silver nitrate referred to in Bulletins 130 and 132, specialise in certain metals and their compounds, often in very pure form. They now have enlarged their range to include many general purpose grade chemicals (called "Matthey Reagent" Grade) in their catalogue. Their prices are, in most cases, substantially lower than those of the usual suppliers of schools chemicals. The carriage is included in the price and the firm boasts a 48 hour delivery on the mainland. To make matters even better they have announced this year that all schools and colleges will receive a 20% discount on the Matthey Reagent grade of solids, with a quantity discount being given on acids and solvents.

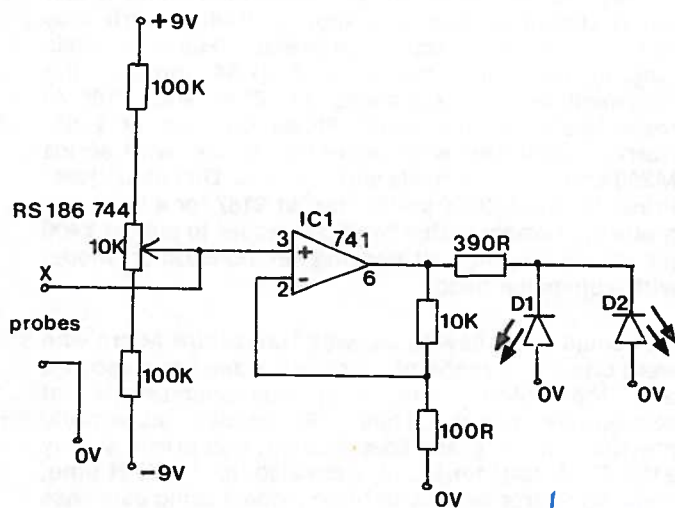

Fig. 2.

*turn diode  
D2 round  
other way*

The circuit shown in Fig. 2 is a tri-state device:

input x	i.e.d. display
positive (20mV)	D2 on
negative (-20mV)	D1 on
floating	D1 / D2 off

The operational amplifier is wired as a non-inverting amplifier with a gain of 100. The function of the

The only drawback is that at the present time the firm does not yet stock all the chemicals which are needed

by schools and it would be necessary to make supplementary orders from a second supplier. A considerable saving could still be made on the annual requisition by purchasing those which are available. Some examples from the Johnson Matthey catalogue are given in Table 1 below along with prices from a more usual supplier of chemicals to schools.

Substance	Quantity	J. Matthey discount price	similar grade from other main supplier
ammonium sulphate	1kg	£2.00	£3.02
barium chloride	500g	£2.32	£3.46
cobalt chloride	100g	£4.40	£6.66
lead(II)oxide	1kg	£2.64	£4.04
lead(II)nitrate	500g	£4.48	£6.68
magnesium ribbon	25g	£1.44	£3.15
potassium hydroxide	1kg	£2.48	£3.79
potassium manganate(VII)	1kg	£4.00	£6.00
sodium hydrogencarbonate	2kg	£1.92(2kg)	£2.02(1kg)
silver nitrate	100g	£16.80	£37.50
zinc sulphate	1kg	£3.84	£5.82

TABLE 1

★ ★ ★ ★

## Trade News

The whole of this section of the bulletin is taken up by a review of the manufacturers' exhibition at the recent ASE Annual Meeting in Manchester.

### Biology Apparatus

**Biotechnology** - As is often the case certain themes in the main programme of the annual meeting were reflected in the exhibitions. One such theme was biotechnology and the need to begin introducing some of its aspects into school science. This theme was echoed on the Gerrard stand with a large scale culture of *Chlorella*, in a fermentation type vessel, being monitored for pH, temperature, oxygen concentration and cell numbers etc. with a range of transducers interfaced to a ZX Spectrum computer.

### Kits

This same biotechnology theme ran through some of the new additions to **Philip Harris Biological's** range of kits and sets for practical biology. For example, a 'Microbiology of Yoghurt' kit, M40483 at £16.50, a

'Saliva Immunology Kit', M86600/9 at £24.75 and a range of new kits for enzyme studies were all launched at the meeting.

### Microscopy

Not biotechnology, but in the same collection of practical sets and kits (all described in a leaflet available from Harris Biological) was a new and welcome aid to teaching the use of the microscope. This is the 'Microdot' kit, M83100/8 at only £5.50. The kit uses the same basic idea outlined in our own Bulletin 108 (October 1978) but takes it a stage further. Sets of test objects, such as protozoan or other cell outlines, are provided on strips of 35mm film. The kit also provides an introduction to simple microscopic measurements using a stage micrometer and an eyepiece graticule.

Microscopes themselves were much in evidence with a number of new models being shown. **Pyser Ltd.**, main importing agents for the Japanese 'Swift' instruments, were showing their new ranges of models with flat field objectives meeting European DIN standards. We have already tested the M250 'O' grade model and a test report should be available shortly. **Philip Harris** also had a new range of four 'own brand', 'Harris' models ranging from the Junior at £121.54 through the Intermediate and Advanced at £140 and £185.78 respectively, to the Harris Phase Contrast at £195. Harris, like Pyser, were also offering the Swift series M250 and M3200 models with the new DIN objectives. Prices for the M3200 series start at £187 for a basic 'H' grade instrument with a fixed condenser to almost £400 for an 'all singing, all dancing' demonstration model with a binocular head.

A small firm, new to us, was **Hampshire Micro** who were offering a range of 'Jungner' school microscopes and the 'Meiji' long arm stereomicroscope at competitive prices. Their J61 model, apparently meeting our 'H' grade specification, was priced at only £108.40. **Artec (I for E) Ltd.** were also, for the first time, showing microscopes with three models using Japanese optics and Indian mechanics. We hope to test samples from both of these firms and to make reports available fairly soon.

**Prior Scientific** were showing their '2000' series of stereomicroscopes. This impressive range of British designed and manufactured instruments should cheer us all up. It reflects another theme of the meeting and Dahrendorf's lectures on TV which many kept disappearing to watch. It demonstrates what British instrument makers are capable of, given commitment to innovation and investment. Prior were also showing a number of school instruments which were fairly obviously from the imported 'Jungner' range. One got the feeling however, that these were very much a stop gap and that Prior's recent heavy investment in new designs and numerically controlled machine tools will result in a new range of home produced microscopes



before long. One can only say "more power to your elbow" to Prior as one of the very few surviving British manufacturers of educational microscopes.

### 'Microvideo'

Until this latest annual meeting we have never afforded more than a casual glance at closed circuit TV microscopy. At the then prevailing prices this was only the stuff of most biology teachers' dreams. This may no longer be the case. With some suppliers offering monochrome cameras at less than £150 and prices of camera mounts and monitors falling, a complete monochrome 'microvideo' set-up for under £500 is now a reality. Such a system was on offer by Pyser.

### In the field

Griffin and George were showing a new Model 20 low cost oxygen meter (DOS-236-G) at £69.50. This uses the now familiar 'dial and LED' system in place of a conventional display. The dial is turned until a red LED lights up, the reading being taken from one of two scales (atmospheric or dissolved oxygen) around the dial.

To ease the taking of water samples for your oxygen measurements Griffin have brought out a conveniently sized sampler for taking 60cm<sup>3</sup> of water from a known depth. The sampler is made of "strong plastic with a weighted base and (has a) reliable filling mechanism". The sampler, cat.no. YPC-514 costs £9.75.

### In the 'up-to-date' biology lab.

Also from Griffin was a movement sensor (YTA-400-M at £43.25) converting movement of a lever into an electrical output for a chart recorder, oscilloscope or computer. Applications for such a device range through neurophysiology (displacing the less versatile kymograph) spirometry, animal behaviour, auxonometry, etc. The same sensor also has applications in chemistry (gas syringe experiment etc.) and physics.

Following on last years breathing monitor based on a vacuum formed moulding, the Griffin spirometer has been similarly restyled. This gives a more sophisticated piece of apparatus than the simple breathing monitor but still keeping the price down at £190.

Some years ago we developed a prototype lamp frame / growth chamber but never published the designs because of their complexity, size and relatively high cost. Now Philip Harris have launched a compact chamber for plant growth studies. Called a 'phytatron' it contains two light sources and has a fan for ventilation. The phytatron catalogue number is B65640/5 and the price £157.

## Chemistry Apparatus

### Balances

One noticeable feature of the exhibitions was the continuing development of electronic balances. On one hand the conventional balances, using load cells, continue to evolve and yet remain competitively priced. At the lower end of the price range several new balances based on strain gauge and other technologies have come on the market and several existing models have been updated. The capacities of the two Oertling Trojan series balances have been increased and given new model numbers. The JC41(4000 x 0.1g) and the JC12(1000 x 0.01g) replace the former JC21 and JB52 which had half these capacities. Thus these new balances satisfy the weighing requirements of range and sensitivity formerly provided by more expensive dual range models. They have the advantage over the latter of being simpler to operate. Priced at £612 to schools they represent very good value. Optional extras such as RS232 outputs, BCD outputs, interface cards etc are available and these may be added at a later time. The same models are also marketed as Stanton balances Model 21 CJ/10 and 14 CJ/10 by Philip Harris (Cat. Nos. C13841/4 and C13845/1) at £680 and £650. Seen on the Griffin stand were the new Mettler balances, PE2000(2100g x 0.1g), Cat. No. BFG-200-G and PE200(210g x 0.01g). These sell at £589 and £580 respectively.

For those with less money to spare is the Stevens X400(400g x 0.01g), sold by Harris (Cat. No. C13823/2) at £430. The smaller, battery-powered balances based on strain gauge or other technologies (many manufacturers are not keen on us opening up these instruments and thus in some cases we can only guess as to the principle used) included the revamped Ohaus Port-o-gram models which were available from both Harris and Griffin. The C300M(300 x 0.1g) (Harris Cat. No. C13816/5, Griffin BCR-210-R) selling at £325 and the C3000M (3000 x 1 g) (Harris Cat. No. C13819/0), Griffin BCR-250-K) selling at £335. These models are small and being battery powered are readily portable. A mains adapter and an anti-theft device enabling them to be fastened to the bench are available as optional extras. Similar instruments from Sartorius were their models 1003(Harris Cat. No. 13806/2) and 1020(Harris Cat. No. C13808/6) selling at £335. In the under £100 bracket are two digital electronic compression balances which may prove very useful in junior forms and are available from several suppliers. Irwin displayed these balances, the 2kg x 5g(or 70oz x 0.1oz!) costing £86 and the 1kg x 2g for £61.25. This latter balance is also available from Harris (Cat. No. C12810/9) for £37.44. (See Fig. 1).

### Chemicals - safety and storage

Reagents have for some time been available at a small extra cost in plastic coated 'shatterproofed' winchesters. Now small laboratory reagent bottles are



Fig 1.

available with this shatterproof coating from both Harris and Griffin. The price from Harris is £2.90 per labelled bottle which also carries the health hazard warning symbols. (Nos C18822/3 to C19320/6). Similar bottles from Griffin (Cat. No. BTJ-510-et. seq.) sell at £2.80 each with one or two exceptions eg. silver nitrate bottle sells for £3.60 and the conc. ammonia for £4.10. The reagent bottles do not have screw tops and hence the value of the extra containment afforded by the shatterproof film will be to some extent reduced.

One particular problem which has beset the storage of chemicals is that of volatile water reactive corrosives, which not only destroy hinges and fittings but may cause a danger if any service pipes are present. In addition a build up of nuisance deposits on the bottles and their labels can occur. One solution to these problems is to store these substances in a special 'volatiles' storage box built commercially by **Ergon Structures Ltd.** to a design by **CLEAPSE**. This GRP enclosure, of dimensions 460mm wide x 160mm deep x 690mm high, has three glass shelves which will each carry six 500cm<sup>3</sup> bottles. Fastened to an exterior wall it is ventilated by the convection current generated by a low wattage heating tape would round the upvc 'chimney' which leads to the outside. A small hole (2½ inches) for this may need to be drilled in the wall. Running off 240V mains it is claimed to give 100 air changes per hour. The lack of a motor ensures quietness and an absence of moving parts. The prices including transport per unit are £120(1), £105(2-10 units). A small cabinet like this will not accommodate winchesters of '880' ammonia or hydrochloric acid. These also fume somewhat and may cause corrosion problems. However many of the fuming metal or acid chlorides sold in up to 500cm<sup>3</sup> lots and which are normally particularly troublesome to store can be kept in good condition.

## pH measurements

Acid rain is a fashionable and worrying topic these days. It has been reported that Banchory sometimes receives rain with a pH as low as 3.5. For those concerned to check on the acidity of the rain in their area, the use of Whatman integral comparison chart pH paper is a very cheap alternative to a pH meter. Another advantage of this type of indicator paper is that when used with coloured solutions any coloration affecting the active indicator segment will similarly affect the colour of the comparison segments. This paper is available in wide range type CS, pH 1-12 in steps of one pH unit, or in six narrow ranges with steps of 0.2 and 0.3 pH. Prices are £3.45 for each pack of 200 strips for the narrow range.

## Database

One item seen at a publisher's stand, which being software and not really within our remit, is still worth mentioning. Longman's Chemical Database (Chemdata 2) comes with datafiles on atomic volume, melting point, ionisation energy, atomic radius, oxidation states, enthalpy of fusion, vaporisation etc. of the first 104 elements. Patterns within the periodic table can be plotted and the facility for superimposing graphs on top of one another makes possible a study of patterns and correlations without the need for the endless manual plotting of graphs. Clearly extra properties or even additional elements can be added to the files. This seems to be one of the more sensible programs currently available. Unfortunately it is only available on disk for RML 380Z machines, but versions for the Apple and BBC microcomputers are being developed. A special order form for Chemdata 2 is available from **G. Gallaghers** (Longman, Micro Software).

## Aerosols

Their refillable aerosol was again displayed by Griffin. It can now be purchased pre-filled with ninhydrin solution as Cat. No. 251-056-01OU for £3.50, 500cm<sup>3</sup> of ninhydrin solution refill being available (251-058-020F) for £4.45. Whilst the aerosol canister is very good value the solution refill is perhaps an expensive if convenient way of purchasing ninhydrin. A plastic version of the aerosol can sells at £1.50. It has the same pressuring system, but has the greater capacity of 300cm<sup>3</sup>. It is not suitable for use with certain organic solvents.

## Chromatography Kits

The well beloved Shandon chromatography kits have over the years become expensive. Less expensive alternatives are now available from Harris in the form of three kits.

Each kit is virtually complete, with the only extra items needed being the solvents and the unknowns. Set 1, the paper chromatography kit (Cat. No. C 25240/S)

contains all necessary hardware including a jar (or tank); jig; spray gun which operates on replaceable pressurised units; spotting pipette; forceps; a comprehensive set of controls (17 amino acids, 3 sugars, 7 food dyes, 4 inks and five solutions of indicators), and two locating agents ninhydrin and p-anisidine hydro-chloride in solid form. This kit sells at £89.00. The thin, layer kit (Set 3) Cat. No. C25300/8, sells at £65. It contains most of the same materials where they apply to TLC. It also includes the plastic sheets precoated with silica gel 60 adsorbent and a chromatography column. The radial chromatography kit in set 2, Cat. No. C25261/2, selling at £29.25 provides a very colourful way of demonstrating chromatography especially with junior forms.

All the kits come in a strong cardboard container with a booklet covering the theory and practice of paper and thin layer chromatography. For those who do not need three or even two self contained sets, money could be saved by purchasing only those items which the TLC kit possesses in addition to those already held in the paper chromatography kit. The Polygram precoated TLC plates (Cat. No. C25630/7) sell at £8.50 for fifty sheets (60x80x40mm) and some extra spotting pipettes at £3.60 per 100 of 5 $\mu$ l capacity will be sufficient to convert Set 1 into a combined paper and thin layer kit.

### Glassware

From Excelo come graduated test tubes ('Gradtubes') in medium wall borosilicate glass ranging from 5cm<sup>3</sup>x1cm<sup>3</sup> to 50cm<sup>3</sup>x10cm<sup>3</sup>. They are available with or without rim, the latter accepting 'Polyplug' bungs. Prices range from £9.00 per 50 of 5cm<sup>3</sup> size (rimless) ie. 18p each to £8.50 for 25 of the 50cm<sup>3</sup> size (rimless) ie. 34p each. The rimmed tubes are approximately twice as expensive. Plastic bases are available to fit these tubes and hence convert them to graduated cylinders (£7.50 for 50 of the 5cm<sup>3</sup> size and £5.40 for 25 of the 50cm<sup>3</sup> size tube).

Priced at £7.70 for 250, the disposable borosilicate glass culture tubes 16mmx125mm from Horwell (Cat. No. 99445.16X) represent very good value. They are useful for many normal purposes including those involving heating, but particularly so for those operations which produce virtually uncleanable test-tubes eg. heating of lead oxides or of sulphur. (Horwell are also agents for 'Gradtubes' - see above).

### Electrolysis cells

Small electrolysis cells fitted with platinum electrodes are available from Oakes Eddon for £6.50 each. How often have you had to explain that the gas evolved at the anode in electrolysis of aqueous solutions of sulphates should be oxygen and not carbon dioxide or sulphur dioxide? The use of a few of the above cells though expensive, should make the point.

### New stand and clamp system

New from Climpex is a retort stand with a new design of base which can be turned into either L shaped or X shaped configurations. In addition the 'legs' can be easily lengthened in order to support heavier loads. This is too expensive a stand at £22.50 (Cat. No. 55/RS) for general use, but is well worth considering for specialised applications. Also worth looking at even if you do not use full Climpex kits are two of the clamps. The flask clamp 55-FC competitively priced at £4.02 will hold firmly any flask of up to 75mm diameter neck in the heat resistant nylon jaws. The special jaw geometry which ensures the correct spacing of clamping contact points for all diameters, together with the more resilient material of the jaws, enables fragile flasks to be firmly held. A spring clamp for flasks of up to one inch diameter neck and 500cm<sup>3</sup> capacity is available at £2.27 (Cat. No. 25-FC).

### Microelectronics apparatus

#### Computer interfacing

There was so much microelectronic equipment on display that it was difficult not to become jaded. This doesn't belie that fact that developments in the technology are impressive. The great improvement on last year is that there are now inexpensive data capture systems which are simple to set up and use. Gone are the days of programming. Gone are the days of wiring up 40-way plugs. It is now possible to buy data capture equipment which comes complete with excellent software that can be operated at the press of a single key.

Griffin and George were displaying their universal interface for the Spectrum. The interface incorporates four relay driven outputs, four switch-sensing inputs, another eight inputs and outputs (TTL), an eight channel analogue to digital converter and an expansion facility, all for £34.77. Expansion packs will also be available. One of these includes an experimental manual and cassette with example programs.

Philip Harris are marketing a single-channel, fast analogue to digital converter at £79 from Blackboard Electronics. Conversion time is 7 $\mu$ s. A program listing is supplied. The device may also be programmed to measure time intervals. Connectors are supplied for Pet, BBC, ZX81 and Spectrum.

Other interfaces from Philip Harris are:

1. A-D-A unit. This is a fast 4 channel ADC, 2 inputs with full attenuator facilities and 2 with fixed gain. Conversion time is 9 $\mu$ s. There is an auxiliary analogue output. The unit can be used with Pet (P87000/1 £76) or BBC model B (P87005/0 £69). Usage with 380Z is under development.

2. Power interface, for control applications, giving 8 outputs rated 1A at 12V d.c. Alternatively any of these outputs may be used for input. Each I/O line is monitored by an LED (P87060/8 £94). Connecting leads available for 380Z, VIC, Pet and BBC micro (each £27), and for ZX81 and Spectrum (£35).
3. Dual input A-D unit. Has two operating modes ADC and DAC. Designed for use with Pet (P87230/7 £59).
4. Pet interface unit. Provides easy connection to the ten user port lines, PA0-PA7 and CA1, CB2. (P87220/4 £46).
5. A fast one-input analogue converter for the BBC model B (£49).
6. Two motor control unit. For the control of one or two d.c. loads such as motors or lamps rated at between 5V and 12V d.c., 1.5A per load. Suitable for microcomputer control or the Harris microprocessor demonstrator (P87800/0 £46).

Harris have also brought out two software packages for the Pet interface unit and ancillary control equipment. The packages are called "Computer control package (P87200/9)" and "Computer control and data gathering package (P87210/1)" at £15 and £17.50 respectively. Similar software for the BBC micro is under development.

We should also mention that Philip Harris are agents for BBC microcomputers. Their price for the model B at £348.26 is the lowest we have seen for one-off Beebs. They are also agents for Oric-1, the new British

microcomputer with a 6502 microprocessor, 48k of RAM and high resolution colour graphics for £147.79. FORTH language is available for Oric.

Unilab have a large robust-looking interface which has initially been designed for use with the BBC micro (Cat. No. 523.001). It features a four channel ADC with a conversion time of 10 $\mu$ s, a trigger system to determine when sampling should start, 8-bit data lines, a DAC and four relay outputs. The estimated price is £150-£170. Unilab are also bringing out a set of modules to interface with a computer for the purpose of illustrating concepts in computer studies eg. card reading.

**Educational Electronics** are very new. The firm was set up last year by some Bedfordshire teachers. They had four modules on display and are manufacturers of a fifth, the VELA, which we will mention later. Of their four modules, three are data capture devices, a multi-channel ADC at £98, a timer/counter at £105 and a storage oscilloscope module at approximately £150. Their fourth device is called the Bedfordshire Interface Module and costs £79.50. Software is supplied for the data capture modules and is operated by single keystroke instructions. Data is displayed in high resolution graphics format and the analysis of the data is achieved by further single keystroke instructions. For example in the measurement of half life, data is initially collected and displayed as a graph of count rate versus time. Hit a key and you have a graph of the logarithm of count rate versus time. Hit another key and you have the best straight line fit through the points. Hit another key and the half life is calculated. (See Fig. 2).

FIG. 2.

"Fig. 2 VDU plots from Educational Electronics' Timer/Counter interface module".

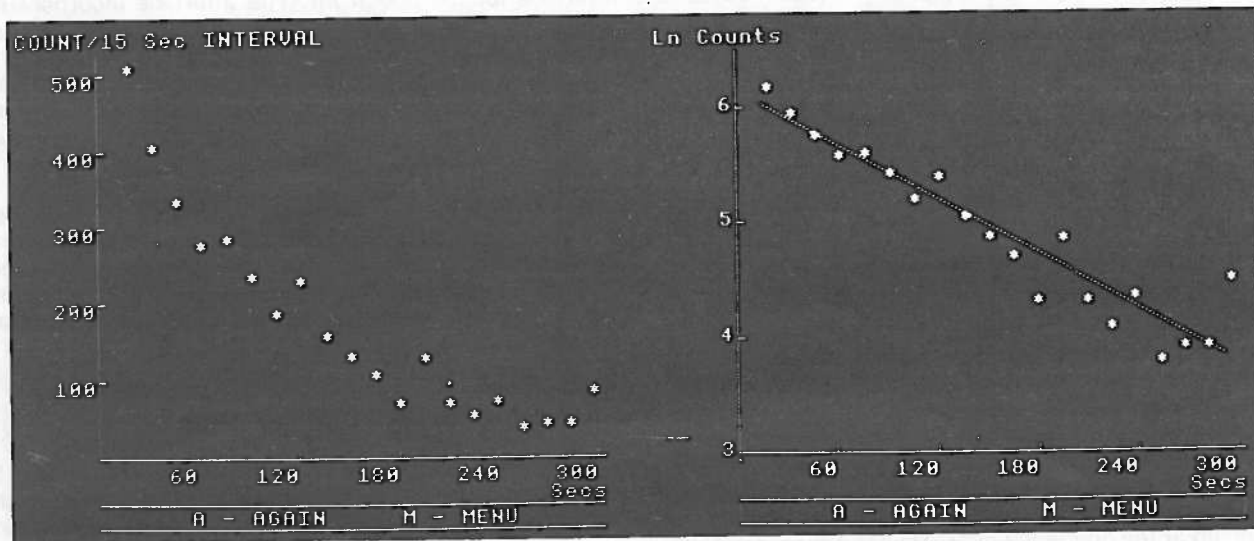

Radioactive decay shown on a linear axis

and on a logarithmic axis, together with a best-fit straight line

Hit another key and the original data appears with an exponential line drawn through. It is not necessary to simulate experiments with a computer. The real thing can be done just as easily. Educational Electronics modules will connect up with the BBC micro and the 380Z. Software will be written for other models if there is sufficient demand.

The **VELA** is a microprocessor-based piece of laboratory equipment which is capable of performing the tasks of many different items of equipment. It will measure voltage, frequency, time intervals, record transients, and much more. Programs are stored in EPROM and there is 4k of ROM allocated to the user. The VELA has an 8 digit display and data can be displayed on an oscilloscope, a chart recorder or on a computer VDU. It will cost £150-£175. It is operated by single keystroke instructions. The VELA project is backed by MEP, the University of Leeds, the JMB and the ASE.

**Irwin** have added to their Micropippa range which they introduced earlier this year. They now have an 8 channel analogue and a 5A mains unit.

Another new company **Cambion Electronic Products** were showing an interface unit that is compatible with the BBC model B and the Pet. Add-on units can be supplied for this.

## Hardware

Three construction kit techniques that lend themselves to computer control are Meccano, Lego and Fischer Technik. The good news is that Meccano is back. **Economatics** Education Division are stockists of all three types of kit and they sell Meccano spare parts. They will send a parts and price list on demand.

**Economatics** are also selling the BBC Buggy in kit form available from March. As the blurb says it is 'the robot that knows where its going'. We can't beat that description. The kit contains stepper motors, circuit boards, cables, software on tape, documentation and instructions. The price is not finalised as yet, but will be around £100 to educational establishments.

## Sensors

Several firms were showing sensors that are compatible with computer interfaces. These were Educational Electronics (temperature, magnetic field), Artec (pressure) and Griffin and George (pressure, temperature, magnetic field and movement).

## Physics apparatus

New models of oscilloscope were displayed by **George Cook**, (who are agents for Hameg.) Philip Harris, **Safgan** and Griffin and George.

For teaching mechanics, **Philip Harris** have an air table kit that costs £165. It comes complete with a demountable gantry for holding a camera above the table. **Unilab** have produced a new stroboscope (432.001) which has a cylindrical mirror behind the tube to produce a uniform beam of light. Also of interest from **Unilab** is a timer module (513.052) at £8.00 that fits into their digital stop clock (513.051) which is £14.50. This module converts the stop clock into a centisecond timer. Timing can be started and stopped by either a single logic gate or by a double gate. **Artec** have a resonance machine at about £19 comprising of four rods, each of different length, mounted on a vibrating beam. **Artec**, in addition to their pressure transducer already mentioned, also stock a Bourdon gauge with a 6" dial. The scale is 0-200kPa with 5kPa divisions. The back plate is perspex to reveal the mechanism. The price is £19.50 plus post and package. It looks very good value for money, though as yet we have not tried it out.

From **Griffin and George** at £99 is a time/speed/acceleration computer, **XBG-500-Q** that has the dedicated measurement features of the mini-microprocessor but which does not have the extra features of programmability and sound production to cause distraction.

Some odds and ends in optics that are new products are an absorption spectra display kit from **Artec**, and extensive photographic kit from **Philip Harris** and two models from **J.R. Moore**, both of which are based on Huygens wavelets. One model demonstrates the principle of operation of a diffraction grating. The other refraction. It is welcome indeed that not all visual models need be ephemeral on V.D.U.'s.

New equipment in electricity includes digital student meters from **Griffin and George** and **Weir**. **Griffin** have three digital meters, an ammeter **EHA-100-R** (top of range 10.00A) a voltmeter **EHB-200-W** (top of range 19.99V) and a microammeter **EHA-910-P** (0-100µA) which serves as a basic meter since shunts and multipliers will fit into this. The meters cost about £28 each. One feature which we like is bipolarity. Polarity does not matter when connecting up the meter, a feature which simplifies its usage. The **Weir** digital student meter (**SMD 10/20**) has two inputs, one for current and one for voltage giving you two for the price of one. It is priced at £29.95. The ranges are 0-10A with a resolution of 10mA and 0-20Vd.c. with a resolution of 10mV. Knowing the common mistake that students practice of connecting an ammeter across a supply, the 10A maximum of the current range will often be well in excess of the short circuit current from many supplies. This would, we suggest, prevent destruction through misuse. Both the **Griffin** and **Weir** meters operate from 9V PP3 batteries. The **Weir** meter can also be used from a 9V d.c. external supply, a jack socket being fitted for this purpose.

There are several mains power meters on the market now. **Weir** are producing an analogue meter (**APC 682**)

at £64 which measures voltage (0-300V AC), current (0-1.5A AC, 0-15A AC) and power (0-360W, 0-3600 W, for resistive loads at 240V). White have a power box and dial for their Interscale instrument (£55) (0-3kW, 0-13A, with divide by 10 pushbutton). For those who are looking for a kilowatt hour meter with sets of circular dials (0-9) Artec are selling reconditioned meters at £26. Reconditioned meters can also be obtained more locally from J.E. Cockayne at £22.50, not including carriage or VAT.

## Electronics

There are new dedicated board systems from Unilab, Griffin and George, Irwin, Limrose and Locktronics.

Unilab are bringing out a new board system to be called the Alpha system, which they will offer alongside the Blue Chip range. The features of the Alpha system are modular single function boards, components supplied in kit form to be assembled by schools, and a novel connector system that partly does away with leads. The two latter features will "ensure that the system is very cheap". The three ranges being brought out are

0 range - sensors, etc.

100 range - digital devices

200 range - analogue devices

eg. inverting amplifier

non-inverting amplifier

differential amplifier

comparator

summing amplifier

Another firm that supplies boards in kit form to be assembled by schools is Tutorkit Products (boards also available assembled). Limrose are agents for Tutorkit. There are four kits available, a combinational logic tutor, a sequential logic tutor and an op amp tutor, at £18 each in kit form. There is also an i.c. patchboard at £24. This comes with 2 x 16 way, 2 x 18 way and 1 x 40 way DIL sockets, a two-speed clock, 10 logic indicators, a manual pulser and 3 logic input switches.

Irwin Desman have an integrated circuits and logic board, EA 2001 in the Micropippa system. The board consists of one 14-way DIL socket attached to 2mm sockets, 4 i.c.'s overlays with logic symbols for each i.c., two logic input switches with indicators and a logic probe. It is robustly constructed. The board could be used to show the principle of operation of simple i.c.s or to operate a simple control procedure. However, it does not seem suitable for expansion linking two or more i.c.'s.

Griffin and George have introduced a new series of digital electronics units. There are eleven units in the range. An instruction manual may be purchased

separately. The units are single function modular. They feature double 2mm sockets which should avoid the use of expensive stackable 2mm plugs. The units include a quad 2-input NAND, dual J-K flip-flop, binary counter, pulse unit, led indicator unit and 7 segment decoder. Perhaps most important of all there is a blank i.c. board.

Locktronics have recently extended their range to include an op-amp kit and logic kit. The op-amp kit (LK 80/E, £32) will require a base board (LK 750, £11) and an optional extra kit (LK80/0, £31) which includes resistors, capacitors, etc. that you may already possess in other kits. The logic kit (LK 81/E, £40) includes 7400 NAND gates. It should be used in conjunction with a baseboard (LK 750), lead kit (LK 81/L, £7) and logic (optional extras) kit (LK 81/0, £12) if you do not already possess standard components.

Science and Technology Education on Merseyside Ltd. (STEM) have brought out a mini board kit that follows the pattern of their standard board. The board has one 14-way DIL socket complete with connecting pins and leads that are uniquely STEM's, and 4 transistor driven i.e.d.'s. The mini board can be supplied in two versions, with 6 i.c.s, an extractor tool and instruction manual (£17.56), or without (£12.26).

Philip Harris have updated their microprocessor tutor and have brought out the Mark II version of their Microprocessor Demonstrator (LP87600/3 £115). The applications of the device are controlled by a set of 18 programs stored in ROM. Some applications require accessory units such as the Two Motor Control Unit mentioned earlier.

★ ★ ★ ★

## BIOLOGY PUBLICATIONS

from

### ABERDEEN COLLEGE OF EDUCATION

#### Field Studies series

Techniques in Biological Field Work - a manual for teachers .....	£1.00
Keys to Moorland Plants (fully illustrated) .....	£0.45
Keys to the Shells of Balmedie Beach - a sandy beach (fully illustrated) .....	£0.45
Keys to Tree Identification (fully illustrated) This includes algorithmic keys for use by pupils who are inexperienced in this type of work .....	£0.70

#### Curricular series

Pupils Learning problems in Certificate Biology The proceedings of the National In Service course on Learning Difficulties, Aberdeen September 1981 .....	£1.00
Pre requisites for Learning some difficult concepts in Biology at 'O' Grade - a book of pupil exercises .....	£1.00
Photosynthesis - a pupil workbook .....	£1.00
Diagnostic testing for pupil difficulties in osmosis - a teachers handbook .....	£1.00

All prices include p and p.

Requests for any of these publications should be sent to P.R. Mills, Biology Department, Aberdeen College of Education, Hilton Place, Aberdeen AB9 1FA. Please make cheques or postal orders payable to "Aberdeen College of Education".

S.S.S.E.R.C.

CONTENTS

Bulletin 134

February 1983

		Page
Introduction	—ASE annual meetings	1.
	—cost index	1.
	—money, money, money!	1.
Opinion		2.
Biology Notes	—re-usable plastic Petri dishes	3.
	—review, "Biology fieldwork Techniques"	4.
Chemistry Notes	—electron direction indicator	4.
	—chemicals costs	5.
Trade News	—ASE annual meeting, trade exhibition review	6.

Bulletin 134      Erratum      Electron direction indicator  
Please note that in Figure 2 the diode D2 is the wrong way round.