

SCOTTISH SCHOOLS EQUIPMENT RESEARCH CENTRE

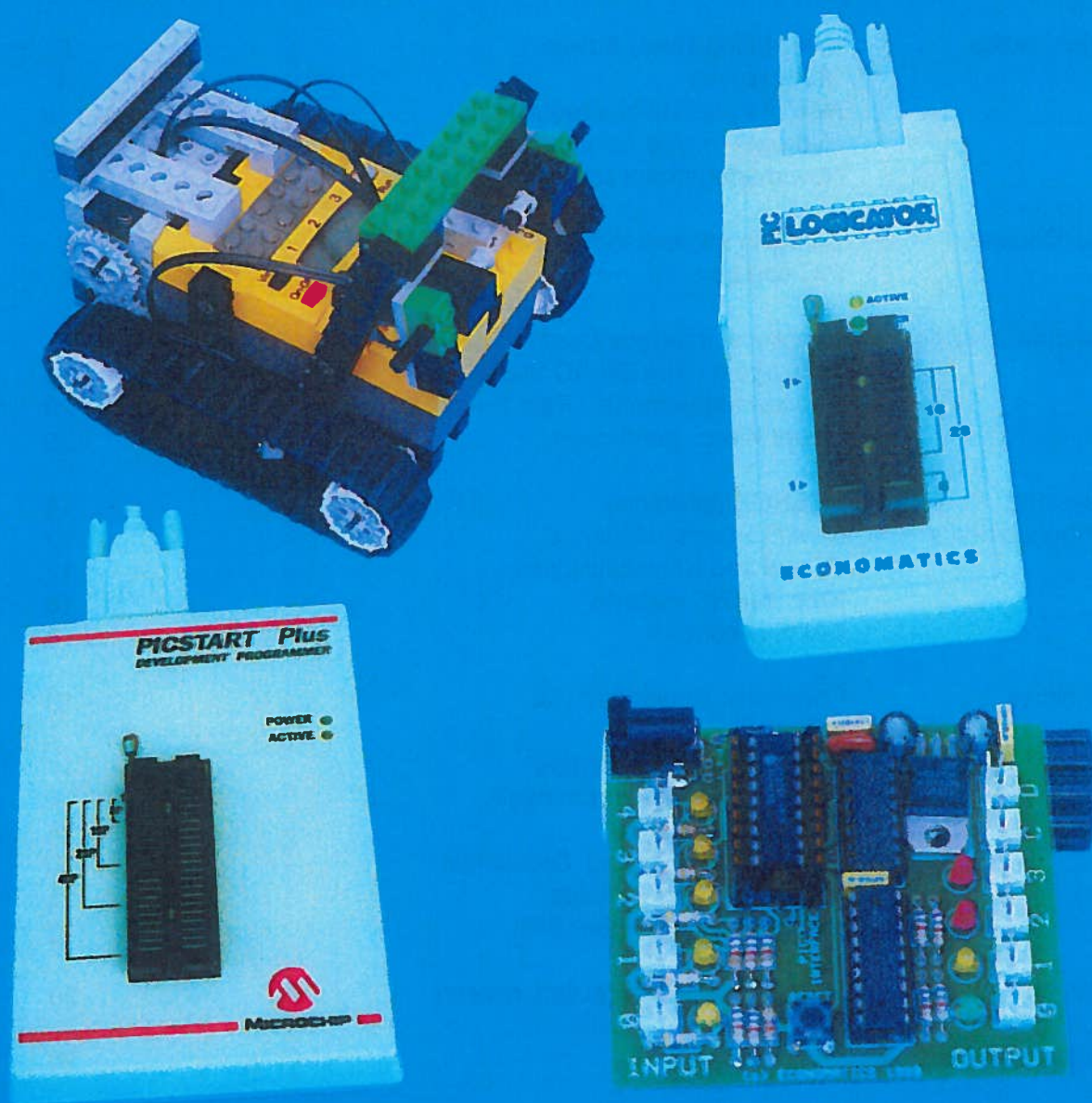

Science & Technology Bulletin

For: Teachers and Technicians in Technical Subjects and the Sciences

ISSN 0267-7474
Number 197

Autumn 1999

Science and Technology Bulletin

Number 197 Autumn 1999

Introduction		1
Opinion	Bah millenium (hum) bug!	2
Safety Notes	Interpreting safety advice	3
	Using gloves	4
	New fire precautions regulations	19
	Hydrogen-oxygen explosions	19
	New management standard	19
New Courses	Safety in microbiology	5
	PIC course	5
Equipment Notes	Peripheral Interface Controllers - PICs	6
	PICs again - The BASIC Stamp	10
	Gas law experiments : Part 1	20
	<i>Robot Wars</i> - gearboxes	29
News and Announcements	SSERC Conference	12
	New Frontiers in Science	12
	School and University Links	12
	New SSERC website	18
	SAPS secondee	18
ICT Notes	Chemistry Equipment List	13
Biology Notes	Higher Still - hints and tips	14
	- test papers for humidity	14
	- finger maze	14
	- anaesthetising <i>Drosophila</i>	15
	- Koch's postulates	15
	Colorimetry and Higher Still	16
Odds and ends	Trade news, technical tips, reviews	28
Equipment offers		30

© SSERC 1999

ISSN 0267-7474

Copyright is held to be waived only for bona-fide
educational uses within current Scottish member
EAs, schools and colleges.

INTRODUCTION

Nowt tae dae wi' us!

We've been getting enquiries and even cheques in payment for another company, one registered in England and which cries itself SSER Ltd. This is becoming more than irritating, since the firm SSER Ltd - like SSERC's trading arms STS (Science Technology Safety) and SSERC-soft - also supplies electronically based safety publications and graphics.

For the removal of any doubt therefore, we would stress that the relatively recently established, south of the border, SSER Ltd has absolutely no connection, that is, as in "none whatsoever", with the Company Limited by Guarantee and Registered Scottish Charity, known as SSERC Limited, which governs this Centre. Neither should any similarity of name lead you into mistaken assumptions as to the quality or otherwise of SSER's wares, on which at present we couldn't possibly comment. As for the "Artist formerly known as Prine" the mind - quite simply - boggles.

Meantime don't buy a SSER Ltd Science Policy Framework - not at £29.38 a throw at any rate. Send us a couple of quid and we'll let you have a tartansised framework based on a policy approved by ASE and first originated by colleagues in our sister organisation CLEAPSS (see SSERC Bulletin 196 page 34).

Litarcy - an uphill urban struggle?

From the City of early intervention, a project designed to raise standards of literacy, came this notice - picked up from under a windscreen wiper of a stationery (?) car :

"Residential Parking Bay Suspension. Date June 1999. Street : (singular but listing 12 in total including "Cannon-gate"). Please note that from the above date the residential parking bays are required to be suspended to Allow :
REHERSAL FOR SCOTTISH PALLIAMENT
OPENING".

Literacy standards in the Capital would seem in need of attention outwith the education department and at levels somewhat higher than those of 5-14. Must be doubly embarrassing, so close to recent election counts which have raised similar doubts about numeracy, in this one time Athens of the North.

Scottish EA Membership

In the last issue, we indicated that thirty one out of the thirty two Scottish Councils as EAs were at that time in membership of SSERC. We are delighted to announce that the single authority then outside the consortium has now joined. Thus our coverage of Scotland is again complete.

Summer Schools 2000

The second Higher Still Biotechnology Summer School hosted by Edinburgh University and supported by a wide range of organisations¹ was again a marked success. It will run again next year but with a different emphasis and thus a rejigged programme. The provisional dates have been set as the week 26th - 30th June 2000. Much of the focus next year will be on Advanced Higher Biology. That course is due to begin in 2000 with the first exam diet in 2001. Not a few biology teachers would probably appreciate the extra help which can be provided at a fairly intensive Summer School.

The success of the two biotechnology schools hasn't gone unnoticed by the chemists and physicists. We understand that planning may be underway for a Chemistry event with Edinburgh again a likely venue. Similar proposals are being mooted for a Physics School but as yet we haven't heard anything as to possible venues, or hosting organisations.

Diary dates

SSERC Annual General Meeting will be held on Friday the 5th of November in the HQ of Scottish Natural Heritage, Battleby, Perth. As usual, a national conference will be held in the morning with some weel kent keynote speakers, discussion sessions etc. This year the theme chosen by the Board of Directors of SSERC is ICT in the Sciences. After lunch we shall deal with the more formal business of the AGM proper of the Company (SSERC Limited), which will be followed by a Board Meeting.

TTA Annual General Meeting: We now have a date and venue for this year's Technology Teachers' Association annual gathering. The meeting will take place on Saturday, 30th October, 1999 and once again will be held in the Hall of Edinburgh Academy.

ASE Annual Meetings : The Association for Science Education UK Annual Meeting 2000 will be held in the University of Leeds from Thursday 6th to Saturday 8th January. It will be preceded and overlapped by the International Programme which begins on Tuesday 4th January. Your copy of this Bulletin issue should contain a flyer for the meeting which includes a response and request form for a programme (available from September onwards). Note that the ASE Scotland March 2000 meeting will be held in Dundee, of which more in a future issue.

Comment

Seen recently, on the wall of a close on the way to the Glasgow Science Centre site at Pacific Quay :

"No Loitering : By Order, The Council"

Rab's weans, Govan's graffiti artistes, vandals and other loitering low lifers must be trembling in their Reeboks.

No comment

Also seen recently, this time above a door to the Glasgow Science Centre Project Office :

"No suits beyond this point"

'ats mair like the thing, ken.

Bah millenium (hum) bug!

A recent television news bulletin included, as a filler, the story that a London hotel, The Savoy (allegedly), was to charge £7,000 for a two-night stay over the millennium holiday. Meanwhile, round the corner at Xanadu (a.k.a. Greenwich), a latter day Pleasure Dome gobbles up our cash. Well, well, and all of this to celebrate the birthday of a simple carpenter (would he still count himself as old labour, I wonder?).

If the technopoliticos and pundits are to be believed then, as those champagne corks pop, China's airport and airline managers will be led screaming to their last flight of the century (not, we trust, literally a case of "Come on down!"); irate customers will besiege banks while nuclear warheads explode willy-nilski all over Eastern Europe. As you know, all of this will be down to those who did not heed government warnings to -

BEWARE THE MILLENNIUM BUG!

Even more terrifying is the thought of all those hasty couplings back in April. Was there a global outbreak of frantic frothing amongst those bravely attempting to ensure childbirth at the very start of the New Year? If so and if they are successful - what will they cry him or her - Millie, Lennie, Neuwan?

And where will you be celebrating the coming of the new century? Perhaps it would be more correct to ask where were you at the start of the new millennium? If, as most scholars and theologians now agree, Jesus was born pre-4 BC, surely we should all have been celebrating in 1996? But, hing on, have we all forgotten Dionysius Exiguus. He was that learned chap who, in the 6th century (whenever that was), introduced a new method of naming the years. Sadly, whilst the pursuit of Christian theology was one of Dionysius's definite strong points, sums and history - just as decidedly - were not. Dionysius had no real idea as to when Jesus was born, only lots of dubious evidence. So, more than five hundred years after that joyous event, he invented our present system of naming the years : BC and AD.

Wee Dennis either didn't ken or simply just wisnae on spicking terms with Arabs or Asians wha kent mair than him. Thus, not having the benefit of a grip on the black art of the zero, his big mistake was to move directly from One BC to One AD. That's right - no nothing - no OAD. This has the same effect as us suggesting we are aged 1 from the moment we are born. By this line of reasoning, the new millennium should have started in 1997.

Then science took a hand in the shape of Kepler who was nothing if not versatile. Very. An astronomer, physicist and mathematician (ie a real smart a . . e), he dismissed poor Wee Dennis oot o'han. According to Kepler, the wee Dionysius had forgotten leap years and

the numpty had probably used an early form of calculator since he'd also missed out four years of the reign of Octavian (Augustus). So, Kepler calculated the birth of Christ at 7 BC (which by itself is a bit of a mind boggling linguistic and numerical paradox, putting as it does Jesus more than somewhat ahead of his time - which of course we now know he was). We should thus all have been celebrating big time back in 1993.

Science being science - and nothing if not consistently inconstant - Kepler's date in turn has since been kicked into the recycle bin. Giovanni Baratta, of Rome, an even bigger SA than Kepler - a professor in astrophysics no less - has more recently computed that the bright star seen over the stable in Bethlehem would have appeared there some five years earlier than suggested by Kepler. Thus either Jesus was already twelve at birth (ouch!) or we should have had the street parties in 1988. Whoever is correct, it seems that - whatever way you want to cut it - sometime ago, somewhat more than 2000 years had already elapsed since the birth of Jesus of Nazareth.

In our supposedly politically correct and ecumenical times what happens, what should happen, in a supposedly multi-cultural Britain? This is year 1378 in the Islamic calendar. Greek and Russian Orthodox time really flies and there it is already 7508. If you're still interested then it's 2312 in the Syrian system and there are many other different figures in use right across Eurasia and the Orient. Does our new millenium matter? Not one jot. It's just another page on the calendar and another year closer either to Heaven or the Apocalypse, yours or mine personally, or collectively otherwise.

My Hogmanay will be spent, as most of them have been over the past decade. I'll be preparing for the annual ASE UK conference. At the meeting, in Liverpool two years ago we met a teacher from a secondary school, with a total annual budget of £350 for the whole science department. That's one-twentieth the cost of a millennium hoolie for one at the Savoy. The national minimum wage means that an employee on such an hourly rate, working a 40-hour week, has an annual salary which would buy that one weekend at the Savoy - just. It's a mad, sad world and even for one as basically optimistic as I, it is difficult to see a bright new beginning to the next millennium - whether it really started in 1988 or will do this coming January. Never mind, we do have our very own, new with a little 'n', Scottish parliament. We can all keep giving Higher Still big licks and soon there'll be a Revised 5 to 14 Environmental Studies document to which to look forward.

What better way to herald in the next 1000 years!?

Iain Mor

SAFETY NOTES

Interpreting safety advice

In recent months we've had a number of enquiries which have arisen from uncertainties of meaning or intent in various kinds of safety information. Some of these were to do with advice or information in manufacturers' or suppliers' MSDSs (materials safety data sheets - see first note below) others concerned different interpretations put on the results of model risk assessments. In particular, it seems that there are difficulties of interpretation over risk assessment results for some of the PPAs (Prescribed Practical Activities) for Intermediate 1 or 2 and Higher Chemistry as published by the Higher Still Development Unit (see note overleaf).

MSDS

Materials safety data sheets can be very useful sources of information, particularly of hazard categories, toxicological information and relevant physical data. Section 6 of the Health and Safety at Work Act places a general duty on manufacturers and suppliers to provide this kind of information. More specific provisions have subsequently appeared. Regulation 6 of the Chemicals (Hazard Information and Packaging for Supply) Regulations 1994 (CHIP) now spells out the detail of MSDSs supply and format. Whilst some suppliers will provide an MSDS in advance of purchase they are not actually obliged so to do. However, where a relevant substance for use at work is actually supplied they are required to provide the MSDS and, in certain specific circumstances, if need be to revise the information up to 12 months after the initial purchase. Whilst safety data sheets can be useful as one starting point in risk assessments for many applications, interpreting MSDS for educational use can be problematic. It requires care.

For example, where the hazard categories and risk phrases to be used with a particular substance have been laid down in the CHIP Approved Supply List, then there should be consistency at least in the phrases used in different suppliers' MSDSs on that substance. Many substances, however, are not listed in CHIP and for these assignment of risk and safety phrases is left to the manufacturer or supplier. There then can be wide disparity in the information provided for the same substance. It is an interesting exercise to tabulate the same parts of different MSDSs from a range of suppliers. Differences in the risk and safety phrases selected by each supplier can be striking [1]. There may also be inconsistencies in toxicological or physical data (depending on the manufacturer's own preferred information sources etc).

Another difficulty is related to scale of supply and use. When drafting an MSDS, few suppliers will have educational applications at the front of their minds. The major share of the chemical and biochemical markets lies in the various commercial sectors. There, the scale of usage is often many times greater than in education. It may well lead directly to the specification of preventive and protective measures which, whilst they may be entirely appropriate to likely commercial applications, are way over the top for an educational laboratory. This can cause needless concern for teachers or technicians trying to make sense

of an MSDS. A recent enquiry on a safety data sheet for glycogen (from oyster) provides a good illustration of this sort of problem. The glycogen was purchased to be used for a Sixth Year Studies Project. It came with a Safety Data Sheet, some of the risk and safety phrases on which nearly gave the supervising teacher apoplexy. For example the section on "Accidental Release Measures" requires the use of a respirator, safety goggles, rubber boots and heavy rubber gloves. The fire fighting part specifies self-contained breathing apparatus. Much of the rest of this MSDS carries on in similar vein with eye protection, local exhaust ventilation, a respirator and much else besides being recommended for handling the substance.

Such advice might just be appropriate on a road tanker or factory scale. It is somewhat less applicable to the CSYS application. Here, the glycogen was to be used in dilute suspension and the total amount purchased was 5 grammes. Donning a respirator to deal with a spillage - even if the whole bottle was tipped out - thus seems excessive. Whilst any biologically active compound should be handled with some degree of respect, an assessment suggested that normal GLP and H (good laboratory practice and hygiene) measures would contain the risks in using the quantities envisaged. The teacher and student were advised accordingly.

Enquiries to SSERC about interpreting MSDS are not uncommon. This single example merely underlines a number of crucial points :

- an MSDS can be very useful in identifying the hazards of a particular substance and may also provide a lot of other data potentially useful for a risk assessment;
- an MSDS is not, of itself, a risk assessment or even the results of a model assessment;
- it is just not feasible to risk assess a substance;
- risk assessment is a process not a piece of paper;
- it is always necessary to consider the actual circumstances of usage viz :
 - *how is the substance to be used?*
 - *what is the scale, concentration, temperature, process or technique etc?*
 - *what is the level or nature of its containment (if it can't get at or in you, it can do you no or little harm)?*
 - *who is going to handle it (do they know what they're about)?*

Conclusion

Treat Materials Safety Data Sheets sensibly and don't ever take them at face value. Use them by all means as one source of information on which to base a risk assessment. But, interpret them with care and always in the context of the detail of the actual application of a substance.

Reference

1. Topic 11 of *Topics in Safety*, 3rd Edition, ASE (in preparation).

SAFETY NOTES

Using gloves

As indicated in the introductory paragraph of this issue of Safety Notes, comment has been made on some aspects of the risk assessments for revised Prescribed Practical Activities for Chemistry. These were published recently as part of the Higher Still Development Programme. In particular there seems to have been some misunderstanding or misinterpretation of occasional advice to wear protective gloves for certain operations. Apparently some teachers are under the impression that the wearing of gloves by students is recommended for a significant number of the practicals. Since the provision of gloves, to students, of the correct type(s) in a range of appropriate sizes is unusual and potentially problematic, some teachers have concluded that the activities cannot be carried out. This is most definitely not the case. A number of specific points arise from this misapprehension.

Firstly, in the majority of cases where gloves have been recommended this has been directed at technicians or teachers handling concentrates, breaking bulk and in generally preparing materials for provision to students. Once dilute solutions have been prepared and materials dispensed into containers the risks are different and nearly always less. Advice on the wearing of gloves has not then been extended to the student part of the overall activity. This is because the circumstances of usage are now sharply dissimilar. Not only are the hazards of the dilute solutions then greatly reduced, but so is the scale, (see, for example, our earlier note on interpreting MSDSs). The requirement becomes one of keeping the material off the skin by normal good handling technique and of not leaving any spilled material on the skin for any significant period. The recommended preventive and protective measures on the student activity sheets reflect these requirements in a consistent way. One example should illustrate these points. Some of the activities, at the preparation stage, require technicians to handle concentrated sulphuric acid in significant volumes. For this process pvc gloves are recommended. Where concentrated acid is handled by students (eg ester preparation) in drop scale quantities or when the dilute acid is provided even in significant volumes, gloves are not usually required. This is because concentrated sulphuric acid is extremely corrosive, it causes severe burns, reacts violently with water and can severely and permanently damage the eyes. Contrast these properties with the same acid diluted, say, to about 0.5M when it is now not even classed as "Irritant".

Only in three practicals is the provision of gloves to students recommended. In two cases students will be handling bromine water, which is corrosive and the potential cause of a type of skin damage which may, at best, be slow to heal. In one of these activities, students also have to handle hydrocarbons which can defat the skin easing the passage of any spilled bromine water and also potentially triggering dermatitis. There are alternatives to the use of the bromine water to which teachers and technicians are referred and whereby the wearing of gloves might be avoided.

In the other instance students have to handle defatting solvents alongside toxic, allergenic and corrosive materials

(respectively - a dichromate which is a sensitiser [and a Category 3 carcinogen but by inhalation], Benedict's and Tollen's reagents). In each of these three activities, the need for hand protection for students is possibly marginal. Nonetheless the balance of advantage seems to lie in providing gloves of the correct type.

Decisions on the use of gloves often involves weighing up such a balance of advantage. This is because the prime objective is to avoid spilling materials or otherwise avoiding contact with the skin. The primary preventive measure then is good technique and sound manipulative skills. Wearing gloves - even when they fit well - nearly always impairs manipulative skills. The use of ill-fitting gloves or gloves of the wrong type may be worse than not wearing any gloves at all. The second line of defence is wiping or washing off, any spillage which does contact the skin. This is a protective measure with which gloves can interfere. For example, if when handling a corrosive your gloves should have a small hole in them then any material which leaks into the glove will be held in close contact with the skin. The first sign that this has happened will be a burning sensation. Then the gloves serve to merely delay washing off the corrosive contaminant. Similar considerations arise over glove types. Using the wrong kind of glove - one which is permeable after a short time to the material(s) being handled - is clearly unwise and may be worse than no gloves at all.

Ironically there is also the matter of a growing incidence of allergic skin reactions to the wearing of gloves intended to protect that same skin. Allergy may develop either to the material of the glove itself (eg to the latex in rubber gloves) or to the dusting powders, such as talc, intended to make gloves easier to don. As before, part of the business of using the results of someone else's risk assessment is tailoring the advice to local or individual circumstances. Where there are known cases of reactions to gloves then other preventive and protective strategies will be needed.

For further advice on gloves and glove types see the SSERC publication *Hazardous Chemicals - A manual for science education* (print or CD version).

Conclusions

The need for provision of gloves for use by students following chemistry courses in the Higher Still Programme has been misunderstood or over-stated in some quarters.

The advice given in the relevant curriculum support materials represents the results of model or generic risk assessments. As for all such model risk assessments, some tailoring to match local circumstances may well be required.

In those few cases where the use of hand protection by students seems the wiser course of action, management and funding issues of the provision of suitable gloves is not qualitatively different in any way from parallel provision of other personal protective equipment items such as eye protection.

New courses

Safety in microbiology

Stevenson College, in partnership with SSERC, has developed a course in microbiological safety. This practical, skills based, course has been written around the former Strathclyde Regional Education Department's Code of Practice. This course is SSERC approved and senior centre personnel have a watching brief to maintain the quality of provision and delivery. It has been successfully trialled with mixed groups of teachers, technicians and FE lecturers with excellent evaluation feedback.

Course Aims

- to familiarise participants with the basic preventive and protective measures required for work in school and college microbiology up to and including Level 3;
- to provide practical experiences and, or refresher training, in a range of basic microbiological techniques.

Content

The course content is closely based on the Code of Practice adopted by the majority of Scottish EAs and the objectives relate directly both to that code and the practical competencies listed in the original Strathclyde Training Course. The course manual contains both instructions for practical work and material to support learning essential theory. Topics covered include :

- Disinfection
- Treatment of spillages
- Media preparation
- Use of autoclaves/pressure cookers for sterilisation
- Subculturing techniques
- Logging and maintaining cultures
- Slide preparation
- Staining techniques
- Disposal of contaminated materials

Structure and format

This is a two day course which is laboratory based. The bulk of the work is practical with each participant having the opportunity to use a wide range of techniques. On day one of the course, media are prepared and a variety of sub-culturing procedures carried out. On day two, materials set up on day one are examined and slide preparation, staining and microscopic examination performed. Note that, at present, the course is run with a one day gap between the two days in order to give time for cultures to grow. The course does not cover setting up and using fermenters (as required by the Advanced Higher) but it is likely that such a session will be made available to occupy day two, thus filling the gap and creating a three day course. The two course tutors are an experienced lecturer and a technician. Other options currently under examination include a three or four day variant with built in assessment for certification of competence and a five day course of training for trainers. For further detail, bookings etc teaching and support staff in Scottish EA schools should channel enquiries through their respective Council. Independent school and college members can contact : Kath Crawford or John Richardson directly at SSERC.

PIC Course

This bulletin issue carries articles on programmable interface controllers (PICs) - see page 6 et seq. These are intended to assist and support teachers of Technological Studies. To underpin and extend that support SSERC, in partnership with Edinburgh University and Allan Whyte of Arbroath High, is offering a one day course. This will cover the use and programming of PIC controllers for Technological Studies at both the Standard and Higher Grade. The course content will cover BASIC Stamp, LEGO Mindstorm, PIC Logicator and PICstart. Participants will be provided with suggested lesson plans (for Standard Grade and Higher Still), relevant PIC programs and - where possible - software for PCs. Initial courses would be held at SSERC in Edinburgh but other venues are under active consideration. A course outline is tabulated below.

Age/stage	Device	Tutor
S1/S2 and S Grade	BASIC Stamp	Alan Whyte
Higher & Higher Still	PICstart	Danny Burns
S Grade & Higher	PIC Logicator	Ian Buchanan
S1/S2	Mindstorm	Ian Buchanan

Table 1 Draft outline programme for PIC course (Alan Whyte - Arbroath Academy, Danny Burns, Edinburgh University and Ian Buchanan, SSERC).

We would ask those individual teachers, technicians or EA staff interested in either attending or arranging such a course to e-mail, write or telephone to note their interest. Should we receive a reasonable response, a series of courses can then be arranged in various airts and pairts. The proposed cost of a course (including lunch, handouts and other resources) is £30 per person per day or part thereof. Demand will be met on a first-come first served basis. Suggested dates which are currently available are tabulated below.

Tuesday 7th December 1999	Tuesday 18th Jan 2000
Thursday 9th December 1999	Thursday 19th Jan 2000
Friday 10th December 1999	Friday 20th Jan 2000

* * *

EQUIPMENT NOTES

Peripheral Interface Controllers - PICs

Kits with PIC control chips of application in Scottish school curricula are reviewed. Some potentially rewarding, educational applications are outlined.

BASIC Stamp

PIC control chips have been used in industry for some considerable time. Up till now they have been slow to find their way into schools. Since the chips themselves are relatively inexpensive, this educational reluctance would seem unconnected with costs. It has probably more to do with the assembly language needed to write a useful program. In offering use of a high level language and free software, the BASIC Stamp from Parallax was probably the first device to hurdle this apparent barrier.

Milford Instruments, TEP (Technology Enhancement Project) and Middlesex University together market boards which use BASIC Stamp. We have considered these boards in previous Bulletins [1,2]. Since then, a number of suppliers of educational equipment have woken up both to the popularity of PIC controllers in industry and their potential for educational use.

A number of firms have now introduced their own teaching packages. These generally come complete with hardware and high-level language software and are reasonably priced. Does this herald the demise of the BASIC Stamp? (But, see also page 10).

LEGO Mindstorms™

LEGO's Mindstorm Robotics was the first of the PIC based kits obtained for our trials. We chose this kit rather than ROBOLAB™ since it is slightly less expensive and the projects suggested are more in keeping with the educational stages (P7 - S1/S2) we had in mind.

This is an impressive package because it comes with a good selection of LEGO bricks and other components; some two hundred in all. The kit also includes plans for building a series of four projects. Most children with an average experience of using LEGO will find building the models quite straightforward. A CD-ROM is supplied which contains all the software needed.

A high level language is used which is not unlike *Prof* or *Control IT*, in its use of one word commands such as "SWITCH", "MOVE", "WAIT" etc. The presentational style of the software is very much 'games orientated'. Computer knowledgeable (nearly typed "literate") children should take readily to the format.

The heart of the equipment is the LEGO RCX™, which contains the PIC and the necessary electronics. Programs are downloaded from the computer to the RCX via an infra red link. The projects are then built around the RCX. Other components can be attached to it in the usual LEGO fashion (Figure 1).

PIC applications

The use of PIC controllers now permeates much of modern life. They are to be found in huge range of devices from mobile 'phones to satellites. Whilst this breadth of application may be within the ken of most children it is not within their experience. Classroom based applications should perhaps be a little more mundane. An instant thought for a starting point is of traffic lights or of pedestrian crossing controls. Boring and too familiar they well may be, but they certainly offer some progression - from the simple program for a light sequence to the use of inputs for the crossing. If the output to a lamp can be controlled, why not to a motor, an alarm, a solenoid or a pump? If a simple switch operates the lights for our crossing, can we not use a reed switch, a pressure pad, an LDR or a thermistor?

Think of a PIC as a shrunken version of the control facilities of the well-loved Acorn BEEB. Effectively, a PIC is a wee stand-alone computer. With a number of the educational kits now on the UK market you still need to build or design electronic circuitry for useful work to be carried out. Some of these kits are reviewed below.

This package will probably be of most use in small numbers for the last year of Primary or the first two years of Secondary. The kit form is good fun and is easy to use. Class sets however could be expensive in the secondary stages. For Standard Grade, or Higher, the PIC can only be programmed with LEGO software and it is not removeable from the RCX for use in other, DIY, devices or artefacts.

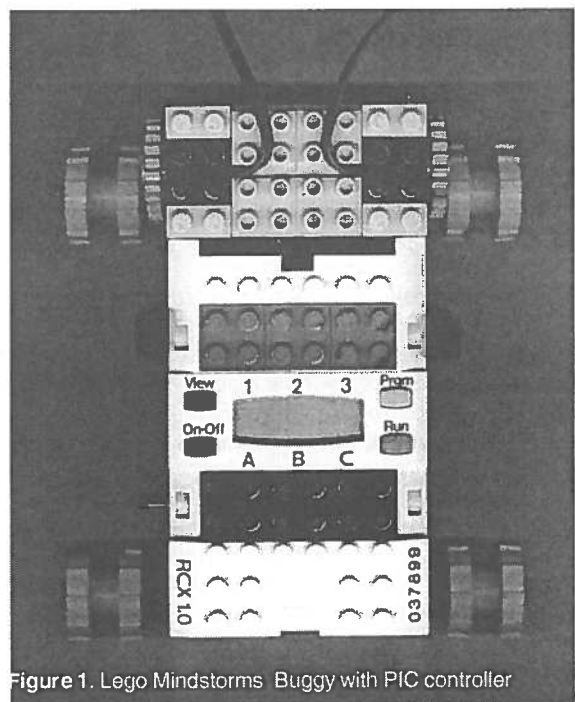

Figure 1. Lego Mindstorms Buggy with PIC controller

PIC Logicator™

Economatics have added a PIC Logicator Pack to their existing LOGICATOR range. This additional pack comprises of a programmer with serial lead (Figure 2), a power supply, and software for Windows based PCs. Said software includes a site licence. There is a single PIC16F84 chip (erase/write) included and you also get a PIC Logicator book. The pack does not, however, contain any parts for model building. Rather it is intended as an introduction to methods of programming the PIC chip for control applications. This can be done using PIC Logicator software with familiar high level commands such as: "FORWARD", "BACK", "WAIT" etc.

Software, to allow students to download machine code routines for more advanced applications, is included in the pack. There is also a facility to allow a teacher to configure the software to introduce simple commands before moving on to the more complex. A project board for the 16F84 is available but at additional cost (Figure 3).

The PIC Logicator is designed to support 5 different control chips, the first of these being the 16F84 with others to follow later in the year. These other chips are the 12F641 digital input, 12F675 (8-pin) with analogue/digital inputs, 16F716 (18 pin), and the 16F873 (28 pin).

Those familiar with a standard Logicator should have no problem with the graphical format of PIC Logicator. The program uses a flowchart to enter choices from a set of commands, of which there are 26 in all. The mouse is used to draw routes between commands (see Figure 4).



Figure 2 Economatics PIC Logicator programmer

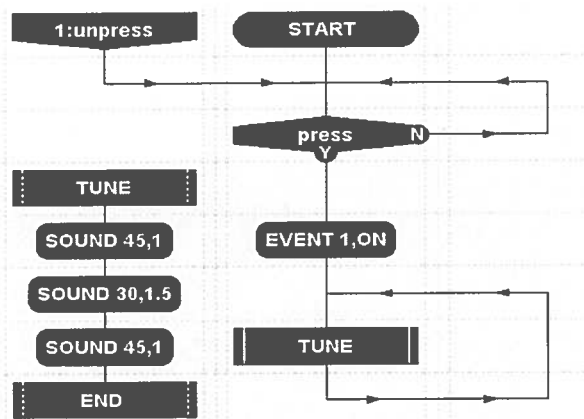

Figure 4 Control program using high level commands plus a macro called *TUNE*

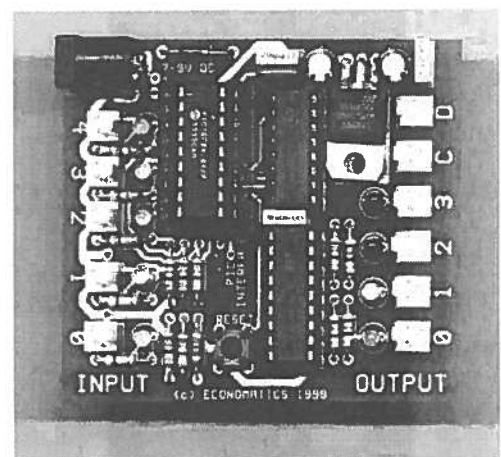

Figure 3 PIC Logicator 16F84 Project Board

It should be noted that programs written for control on the standard Economatics Logicator cannot be downloaded to this PIC chip.

The program shown in the screen dump as Figure 4 makes use of a macro called *TUNE*. If used with a toy teddy bear, a noise would be made when the toy was squeezed or pressed. You would of course need a micro switch to start proceedings. Programs can be fully tested before downloading and there is the additional on-screen facility of observing the state of both the inputs and outputs. Downloading could not be easier. The chosen chip is placed in the zero insertion force socket, the download icon is clicked, then - all being well - the program is loaded into the chip.

cont./over

PICSTART Plus

This system was developed by Microchip Technology and provides a professional system at a price well within a school department budget. The system is designed to operate on any PC compatible machine running under Windows 3.1 or higher. The pack contains all necessary cables, power supply, development programmer (Figure 5) with 40 pin zero insertion socket, documentation and a PIC chip sample; this device being a 16C54, which is one-time programmable (not erase/write).

The software is known as *MPLAB*. The system uses a form of assembler code to program the chip. This appears difficult at first sight but, like all such skills, becomes easier with practice. As with the PIC Logicator there are no models or kit parts supplied, but in any technology project the electronics needed to interface the chip with a model should be straightforward. We have used the *MPLAB* software to download a program to a 16F84 and found no problems.

Both the 16C54 and 16F84 need an external oscillator. We found a simple *RC* oscillator the least expensive, easy to build and it works well. Recommended resistance values are between 3 and 100 k Ω and a capacitor greater than 20 pF. Our circuit used what was to hand which was 4.7 k Ω and 20 pF.

Since the *MPLAB* software is being continually updated, we are confident it will support the new generation of 8 pin analogue/digital chips to be introduced later this year. The latest version of the software is free and it can be downloaded from the Microchip Technology website at:

<http://www.microchip.com>

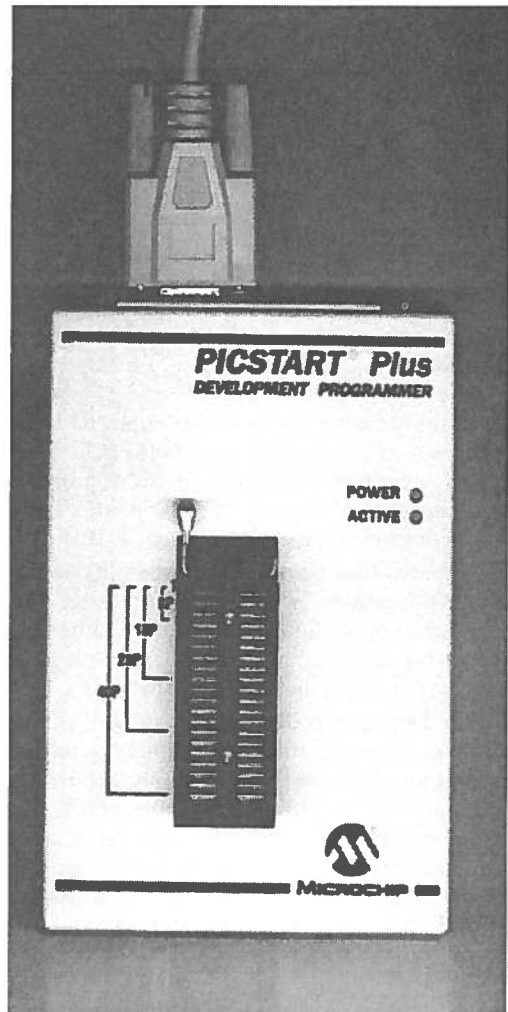

Figure 5 PICSTART Plus Development Programmer

The *MPLAB* software has a built in editor, assembler and simulator. Examples of typical instructions are shown in the Text Box opposite. Once the program has been built it is assembled and any errors are highlighted. These instructions can then be edited and retried until the routines are error free. The program can then be run through the simulation operation before downloading to the chip.

Typical instructions are shown in the Text Box opposite. *Note that these are examples only and that what is shown is not a working program.*

A useful publication to complement *MPLAB* is 'PIC Your Introductory Course' [3].

```
; Program function:
list          P=16C54 ;Number of PIC being used
include      "c:\pic\p16C54.inc" ;software file

;Declarations
porta equ    05      ;set up port A file register 5
portb equ    06      ;set up port B file register 6
org         1FFh     ;labels instruction start
goto       Start
org         0        ;instructions now start from 0

:Subroutines:
inif      porta     ;clears port A
cirf      portb     ;clears port B
movIw    b'0011     ;moves number into working
register
tris     porta     ;moves number to select bit as
input/output
movIw    b'00000001
tris     portb

;Program Start:
Start    bsf      porta 0      ;sets bit 0 file register 1
                                ;turns on buzzer or LED
```

Summary and Conclusions

Device/Kit	Supplier	Cost	Curricular Context
<i>LEGO Mindstorm</i>	Commotion	£160.00	P7/Standard Grade
<i>PIC LOGICATOR</i>	Economatics	£125.00	S/Grade/Higher
<i>PROJECT BOARD</i>	Economatics	£29.50	As above
<i>PIC16F84</i>	Economatics	£27.50 pk 10	As above
<i>PICSTART</i>	Rapid	£125.00	S/Grade/Higher

Table 1 Summary of the details of the various kits and add-ons together with approximate costs.

LEGO Mindstorm

Fun to use and easy to program but, like many other kits, is restricted in what can be built. It shares with the other kits tested the major advantage that a single computer can program any number of PIC controlled models. Mindstorms would cover most aspects of control technology from P5 (Year 5) to S2 (Year 9) and yet may still have a place in Standard Grade Technological Studies. Pupils at Higher Grade and Higher Still would not be best served using this kit.

PIC LOGICATOR

Simple to program and with the addition of a project board can be easily attached to models. Does lend itself to some progression and could be introduced at S1 (Year 8) using the high level language and yet still be useful at Higher using assembler code. The PIC chip provided can be interfaced as a stand-alone component by those with a basic knowledge of electronics.

PICSTART Plus

Uses a machine code to program but is perhaps the most versatile. The software enables a large variety of chips to be programmed and, as with the Logicator, those with basic electronic skills should be able to build models for control. Initially may only be of use at Higher but with experience could be used at Standard Grade.

Best Buy

Of those kits we have evaluated, including the *BASIC Stamp*, Economatics' *PIC Logicator* is probably the best buy for schools. As teachers' and students' experience with the chips builds up, *PICSTART* would be a good option for more advanced pupils.

References

1. *Programmable controllers - Part 1*, SSERC 1997, Bulletin 192, 12.
2. *Reaction timer with the BASIC Stamp*, SSERC 1998, Bulletin 193, 24.
3. *PIC Your Personal Introductory Course*, John Morton, 1998, Newnes, ISBN 07506 3932 6.

(Newnes is part of Butterworth Heinemann. Website - <http://www.bh.com>)

EQUIPMENT NOTES

PICs again - The BASIC Stamp

Applications of the BASIC Stamp to technology courses in the earlier secondary years are outlined.

S1/S2 Stamp?

In the preceding review it was hinted that applications of the BASIC Stamp type of programmable controller might soon be, or already has been, overtaken by events, at least in the later curricular stages. Here the BASIC Stamp is revisited in different curricular contexts. This is the first of a series of articles on control technology at the 5-14 level and on into Standard Grade Technological Studies.

Alan Whyte of Arbroath High School has been using the BASIC Stamp to develop learning and teaching activities on control applications for technology courses at the 5-14 level. He decided to work on a design for a model of disco lights. He knew that most, if not all, of his charges would have experienced them. And, it least it made a change from the ubiquitous traffic light sequence. Figure 1 (opposite) is a photograph of the finished board. Figure 2, below, shows the simple circuit diagram. A list of the parts required is tabulated as Table 1.

The cost of the finished board is around £3.

Figure 2 (Below) Circuit for disco lights BASIC Stamp not shown.

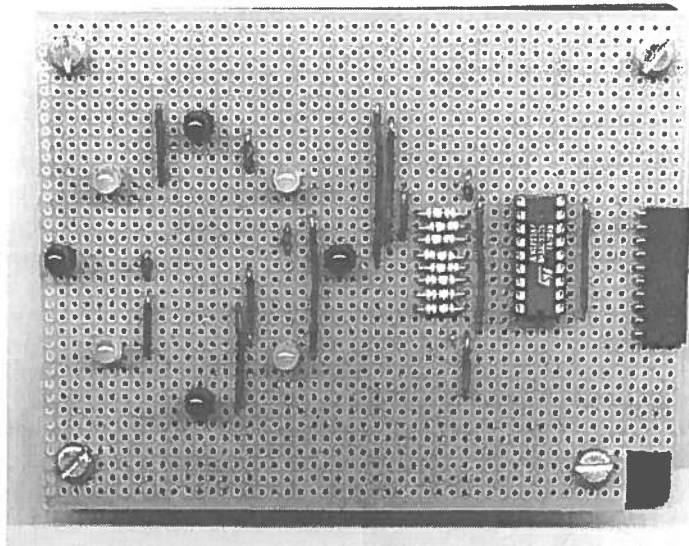
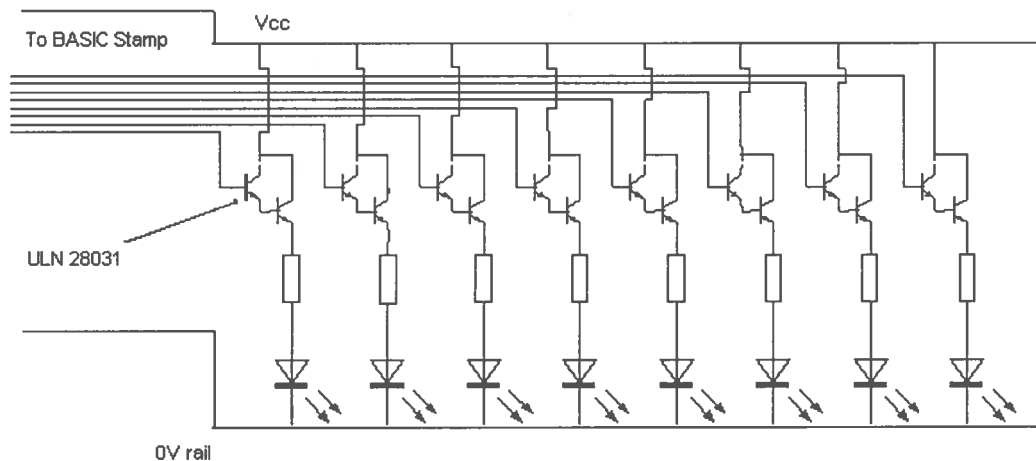

Figure 1 Disco lights project board

This was a highly successful set of activities. Alan has now produced other boards using the Stamp as a relatively inexpensive means to apply control technology. Some of these boards are to be introduced in S1/S2 (Years 8 and 9) or possibly P6/P7. (cont./opposite)



Quantity	Description	Rapid Part No.
1	10 way right angle PCB socket	22-4116
1	Darlington driver	ULN-28031
1	18 pin socket	22-0415
1	Stripboard	34-0515
8	1K Resistor	62-0556
4	Green LED	55-0120
4	Red LED	55-0115

Table 1 Parts list for disco lights project board

Stamp board

Following on from this initial success, Alan has now produced a teaching aid to be used with the BASIC Stamp in Standard Grade courses. Figure 3 in the right hand column, shows this board. It is intended to enable pupils to program both digital and analogue inputs as well as to reverse outputs. Power is derived from 4 AA cells positioned on the board. There is little or no danger of damaging components by applying too great a current or voltage. There is now a Mark II version which has the BASIC Stamp wired and mounted on the board itself.

Costing this teaching aid as a kit, we estimate that it could be built for around £50, which total includes the cost of one Stamp controller chip.

Future Bulletin issues may continue this PIC theme, with suggested lesson plans using BASIC Stamp at Standard Grade. Note also the offer to provide training set out on page 5 of this issue. In the meantime should you require further information on any of the learning and teaching aids for BASIC Stamp or you wish to swap information and ideas please contact Alan Whyte on e-mail at :

zahwhytea@arbroathhigh.angus.sch.uk.

Figure 3 (Opposite) Mark I teaching board for the BASIC Stamp. Has digital and analogue inputs/outputs reversing facility and on board battery supply.

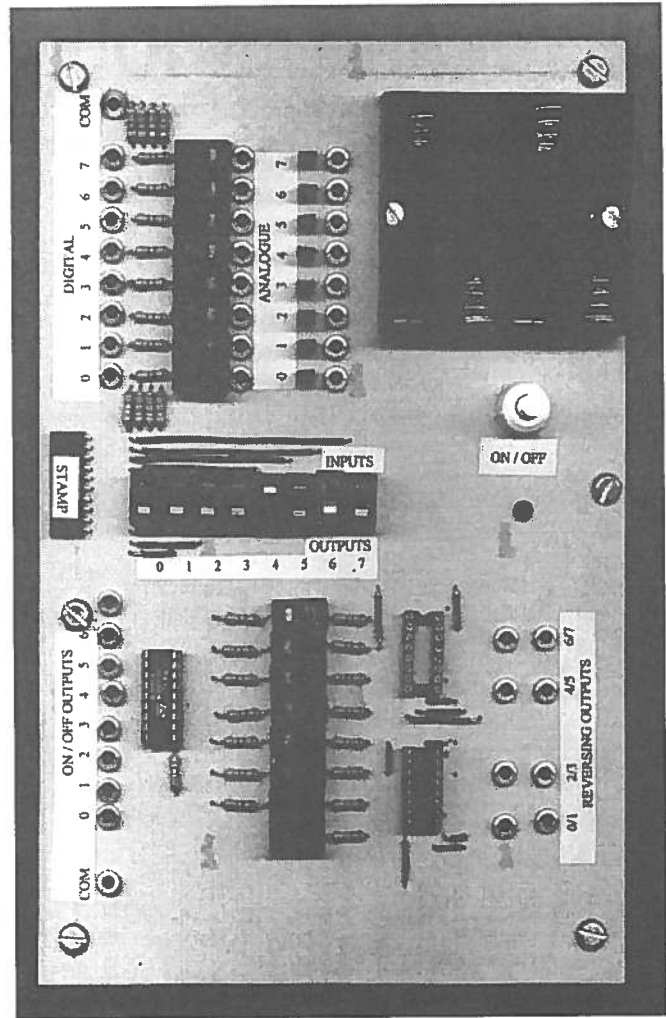

COMMENT

ICT issues

Thanks to the anomalies of desk top publishing on a PC network, this issue of the Bulletin has taken an inordinate time to put together. Not the least of the problems of DTPing with *Windows*TM based packages, is the frequently disproportionate amounts of memory used by PCs for most affordable forms of graphics handling software. Coming as we did from a *RISC* (Reduced Instruction Set Computer) background we have found the performance of our *Windows NT*TM system woeful, in comparison even to our Archimedes systems. In the end, we bought a secondhand RISC PC to do much of the graphical donkey work, only translating illustrations into PC acceptable formats at the last minute. Put it this way - we're now not at all surprised that others have found it necessary to found a "MicrosoftTM sucks!" club. Other applications on PCs are, however, more impressive. Packages such as Excel, Access and Explorer are more than okay. But, even they can irritate somewhat. What with all of the bells, whistles and *Help* menus bolted onto every package, there is the distinct impression that you are constantly being patronised by some spotty, anoraked, Herbert who thinks they know better.

Too often for comfort - they don't.

Our experience to date with a *Windows NT*TM network, reinforces the widely held educational view, ie from outside corporate ICTdom, that total reliance on a single platform in schools may well prove unwise. "*Horses for Courses*", like many cliches, carries a significant element of truth.

Concern has been expressed that hybrid networks are significantly more difficult to manage than those using a single platform. This is not borne out in SSERC's experience to date. Our network has two *Windows NT*TM servers with mainly PC workstations. But, we have an Acorn A5000, a RISC PC and an Apple iMac thrown in to do what they're good at. So far, this mixed network has not presented any problems which are not far outweighed by the benefits brought to the system as a whole by the non-PC machines. We know of schools with successful mixed networks of 300 or more machines - plus peripherals.

So, we are not at all convinced by the apparent current scramble to jump on the so-called '*industry standard*' bandwagon. In fact, having now seen RISCOS 4 running with the new versions of Draw, Vector and Image FS, and on hearing that PACE is building new RISC machines, we could be tempted to abandon *Windows*TM, bells, whistles counter-intuitive quirks and all.

Tailpiece

Just to reinforce the point about graphics and memory:

A friend of mine (I do have them), engaged in ICT support for twenty odd years, gave a presentation recently in which he showed a picture of the mainframe computer whereat he started his ICT career. His virtual computer - a PC generated graphic was 20 Kb bigger than the entire RAM of the real computer on which he had worked. Funny thing - progress.

NEWS AND ANNOUNCEMENTS

Some key events will mark the 1999-2000 Scottish science and technology education calendar. A selection of these is described below.

SSERC Conference

As indicated in the Introduction (page 1) SSERC's own Annual Conference will be held on Friday the 5th of November 1999 within the Scottish Natural Heritage Building at Battleby. This venue is adjacent to the northbound A9 just outside Perth. The theme of the Conference will be :

Information and Communications Technology in Science Education.

Mr Peter Peacock MSP, the Deputy Minister for Children and Education has very kindly agreed to be the opening keynote speaker. An outline programme is set out in the text box below.

Effective Implementation of ICT (Information Communications Technology) in Science Education and Health & Safety Management

9.30-10.00 Registration and coffee

10.00-10.10 **Welcome and introduction** : Councillor David McGrouther, BA, JP, Chairman SSERC Limited and of the Education Committee, West Lothian Council.

10.10-10.30 **The Role of ICT in Science Education**
The Scottish Executive Education Department's view. Peter Peacock, MSP for Highlands and Islands. The Deputy Minister for Children and Education.

10.30-11.00 **The Scottish Support Network for Science (SOLSN Project)**: Ian Birrell, Network Designer, STS/SSERC

11.30-12.30 **Implementation in Scottish schools and EAs**

a) Speakers from schools illustrating some successful applications of ICT in learning and teaching in science

b) Ian Helmsley Fife Council illustrating some successful applications of ICT in the administration and management of Health and Safety issues.

12.30 - 13.00 **ICT and Health and Safety** : ICT as both a resource for, and a source of problems in, safety management : Annette Hall, HM Inspector, Health and Safety Executive National Interest Group for Education.

13.00-13.45 Lunch followed by **Annual Business Meeting and Board Meeting of SSERC Limited.**

Places at the conference are limited and will be filled on a first-come, first served basis. The conference fee for members, including lunch and all refreshments, papers etc is £30 (Non-members £55). Enquiries to Anne White here at SSERC please.

New Frontiers in Science

The Royal Society of Edinburgh (RSE) will be hosting a Scottish version of this important exhibition. It will initially be staged by the Royal Society in London with a major part of the exhibition then coming to Edinburgh on the 28th and 29th of June 2000. The venue is to be the RSE's newly extended and refurbished premises in George Street. The Scottish New Frontiers exhibition will be linked with a thematic event on Information. This will draw parallels between biological events and the evolution of informatics. Although the exhibition will be staged only in the capital, there is to be a national competition for schools with significant prizes. We shall provide further information, on both the exhibition and the competition, as it becomes available.

School and University Links

The Faculty of Science and Engineering at Edinburgh University has an interdepartmental Advisory Board on the Public Understanding of Science, Engineering and Technology. Membership is drawn from both the academic staff in the faculty and external specialists and educational advisers. Recently the Board appointed some of its members to a Task Group to look at ways in which the University might better support science and technology education in schools. This group, just like the parent board, has a mixed membership of faculty personnel and others from outwith the University.

The task group has proposed and is to organise a Schools/University Conference. The aims of this conference are to :

- raise mutual awareness of contemporary issues in both schools and higher education establishments;
- examine the implications for learning and teaching for students in both sectors;
- identify possible subject-specific, collaborative projects for joint development and
- establish practical means by which to take the best of such ideas forward to eventual implementation.

The one day conference will be held in University premises and the provisional date is Wednesday 26th January 2000. The audience will be a balanced mix of university lecturers and school teachers. Their subject specialisms will cover the sciences, engineering, technology (including informatics), maths and geography. Schools within a fifty mile radius of the University will each be invited to send up to two delegates. This will either be by direct invitation or through an employing authority. Although this is an Edinburgh University initiative, staff of other universities will be invited to attend and, since such a conference could prove a model for similar initiatives elsewhere in Scotland, observers may well be invited from Higher Education institutions outwith the immediate area. As a national centre we should like to endorse both this Edinburgh University initiative and the idea that it might be extended to other Universities and neighbouring schools elsewhere in Scotland. A good start would be to stage similar events in the west and north of Scotland.

BIOLOGY NOTES

Higher Still - hints and tips

We've had a significant number of technical enquiries and other requests for information, all of which seem to have some connection with various biology courses forming part of the Higher Still development programme. We judge that teachers and technicians might find it useful if we collected edited versions of our responses to these and publish them in a specific section of the Bulletin.

Test papers for water, humidity etc.

The use of cobalt(II) chloride or cobalt(II) thiocyanate papers to test for water and for semi-quantitative measurement of humidity levels is described in a wide range of school science texts. Somewhat harder to find are recipes and methods for making such test papers. Either the chloride or thiocyanate versions may be used for such tests, although it is on the thiocyanate version that we have had recent enquiries. Both types of test papers are available commercially from the usual range of suppliers. But, if you are particularly keen to make your own there are recipes in Creedy [1] for the chloride version and for both in Archenhold, Jenkins et al [2]. Unfortunately, these references, we think, are now out of print and - they differ!

Creedy's recipe for cobalt chloride paper says 1g in 100 ml of water, dip paper and dry. Archenhold et al on the other hand, offer :

- 1 Cobalt chloride papers says 1 g of cobalt(II) chloride crystals in 20 ml of distilled or deionised water, soak filter paper in solution, remove and allow to dry. Cut into strips and complete drying in an oven at just over 100 °C. Once fully dry store in a plastic bag with anhydrous silica gel (preferably with the bag in a desiccator with more gel). It may be necessary to re-dry the papers immediately before use.
- 2 Cobalt thiocyanate - as above, but use 5 g of cobalt(II) thiocyanate in 20 ml of distilled or deionised water. Soak, dry and store as for cobalt chloride paper.

On balance we suggest you heed Archenhold et al. As to the hazards of cobalt compounds and the risks of usage for the test papers, see the relevant section of the SSERC Hazardous Chemicals Manual [3]. If human skin is to be tested for the presence of water then it's best not to apply the test paper directly to the skin. Place the hand in a glove or a plastic bag and test the condensate which will be produced.

References

1. *A Laboratory Manual for Schools and Colleges*, Creedy, J., Heinemann Educational, 1983 edition, ISBN 0 435 57130 3.
2. *School Science Laboratories ; A handbook of design, management and organisation*, Archenhold, W.F., et al., John Murray, 1978, ISBN 0 7195 3436 4.
3. *Hazardous Chemicals : A manual for science education*, SSERC, 1997, ISBN 0 9531776 0 2 (also published as an interactive manual on CD ROM).

Finger maze designs

The Genetics and Adaptation Unit for the new Higher Biology course retains a suggested learning activity entry on "The effect of practice on motor skills". When this kind of activity, related to the business of 'learning curves' was first introduced into Scottish biology courses, we used to exhibit a couple of DIY designs. Each of these owed their origin to Nuffield secondary science materials. One was a mirror maze, which on reflection (sorry!) was somewhat over-demanding even for the most dexterous of students. The other was a finger maze using raised, narrow wooden strips on a plywood base.

The idea behind a finger maze is that a blindfolded subject has to trace out a path along the narrow (ca. 1 cm wide) raised strips. A number of strips, obviously, stop blindly at dead ends, 'T' junctions etc, at which points the subject has then to retrace their path to find a continuous way through the 'maze'. Students usually work in pairs - one running the maze - the other doing the timing and watching out for cheating.

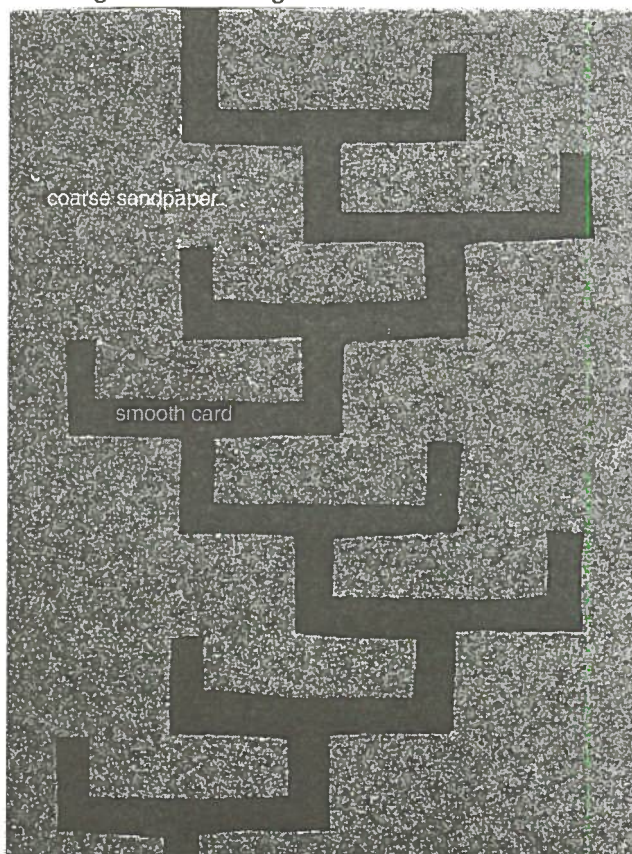

Figure 1 Scanned image of actual sample of maze reduced to ca. 50% of original image size, and 'optimised'.

Successive attempts, out of say a total of ten, are each timed to completion. Results for individual subjects are best aggregated (across a whole class, say) to obtain a large sample. Mean times per attempt are then plotted against the number of attempts which at that point had been made. What then emerges, with any luck, is a graph with a fairly convincing downward trend. This is a learning curve which demonstrates that facility with a given task based on motor skills improves with repetition or practice.

Although reliable and robust, wooden finger mazes of the Nuffield pattern are time consuming to make and may be awkward to store. In the Summer we received an idea for, and sample of, a simple yet elegant alternative design using sandpaper and card. The method of construction is straightforward (see Figure 1 previous column). A simple maze pattern is cut out of a roughly A4 sized sheet of fairly coarse sandpaper. That pattern is then backed up by glueing a sheet of smooth card (ca. 160 gsm) to the back of the sandpaper. Multiple copies of the maze can be made quite quickly.

Acknowledgement

We are most grateful to Sheila Innes of the Science Department Inverurie Academy for sending in this idea and a sample of the maze design.

* * *

Anaesthetising *Drosophila*

This note is based on a piece first published by our sister organisation CLEAPSS School Science Service in their own Bulletin. The appearance of this note by CLEAPSS is timely. We have had a number of enquiries on substitutes for ethoxyethane as an anaesthetic.

One use of ethoxyethane (diethyl ether) is to anaesthetise *Drosophila* fruit flies. This, however, is EXTREMELY FLAMMABLE and a narcotic - at higher concentrations its vapour may not just put the flies to sleep! Some EAs have placed restrictions on the use of ethoxyethane. This can pose difficulties when transferring fruit flies in setting up genetic crosses. For some time, there has been an alternative to ethoxyethane for such work: a product called *FlyNap*, but you had to purchase it from Carolina Biological in the USA. Now, however, it is being marketed in the UK by Blades Biological at £8.49 a kit. CLEAPSS have tested out a sample, courtesy of Blades.

The *FlyNap* kit consists of a 10 ml bottle of anaesthetic and 12 'wands' which are dipped in the anaesthetic and then inserted into the *Drosophila* culture bottle or tube by momentarily pushing aside the foam stopper. The wand is left in place for 4 minutes. The flies are anaesthetised inside their culture bottle (beware of dozy flies plunging into the food medium, from which they never escape!) and then tipped out for sexing etc. There is thus no need for that tricky operation of inverting the culture into a funnel attached to a flask (unless the food medium in the culture is sticky and fluid, in which case flies are best transferred to a clean tube before anaesthetising). Flies remain anaesthetised for at least 50 minutes and often for several hours. (This could be an advantage over the use of ethoxyethane as the anaesthetic. Fear of over-anaesthetising the animals, may mean exposure to the ether is too brief and flies may recover at an inconvenient moment! However, waiting for many hours while *Fly-*

Napped flies regain consciousness can become rather tedious.) *FlyNap* is not supposed to have any ill effect on the flies, so CLEAPSS staff tried exposing them to the anaesthetic for double or triple the recommended time. The majority of the flies did come round but it took well over 6 hours!

So, what is in this anaesthetic? Well, it contains 50% triethylamine (HIGHLY FLAMMABLE; CORROSIVE; HARMFUL to the eyes, in contact with the skin and if swallowed), 25% ethanol (HIGHLY FLAMMABLE) and 25% 'fragrant' (to mask the smell of the triethylamine!). This all sounds pretty horrendous but we are confident that *FlyNap* can be used safely. Students will be exposed to only a very small amount. However, *FlyNap* does have a distinctive odour. Gauging the 'offence rating' of an aroma will always be rather subjective but we found it decidedly unpleasant. Even a trace left on the fingers (easy to do when handling the wands) leaves a lingering smell that does not easily wash off, so we certainly recommend wearing gloves. Another problem arises when a wand is inserted into a culture tube: it is easy to contaminate the stopper with the anaesthetic, so flies may continue to receive a dose of *FlyNap* after the wand is removed.

Overall verdict : We do not consider that ethoxyethane is so dangerous that it should not be used; suitable precautions can usually be taken. *FlyNap* is, however, an effective and useful alternative which deserves consideration. Another possibility is the use of a freezer block as a DIY cryostat - of which more, anon.

Acknowledgement

We are most grateful to colleagues at CLEAPSS for permission to use their original article as a basis for this present piece.

* * *

Plant pathology - Koch's postulates

We've had a recent enquiry about a SAPS protocol for demonstrating these important microbiological principles. A student had downloaded a procedure from the SAPS website but was following up with an enquiry about some of the detail as to recipes for media, sources of cultures, ingredients and reagents. The purpose of this present note is to bring the attention of readers to a more recent and detailed account which has just been published in *Osmosis* - the SAPS Newsletter [1]. In addition we've ordered up the materials and intend trying out the procedures here in SSERC so as to be better placed to assist Scottish teachers and technicians with any further enquiries.

We know that the SAPS Newsletter does go into a lot of Scottish schools but there must still be a number without access to it. If your school does not receive *Osmosis* it's well worth getting onto the mailing list. For example, in addition to the material on Koch's postulates in the current edition there are notes on an ELISA (Enzyme Linked ImmunoSorbent Assay) kit to detect the fungal pathogen *Botrytis* and a number of other interesting bits of news and technical or other useful snippets. If you don't yet receive a copy of the newsletter then contact SAPS head office in Cambridge (see inside back cover for contact details).

Reference

1. *Osmosis*, SAPS Newsletter No 16 Autumn 1999 : Student Sheet 18

BIOLOGY NOTES

Colorimetry and Higher Still

An account of selected applications of a colorimeter in biology practicals included in the Higher Still Support Materials

A number of the practical schedules, provided as part of the Higher Still Support Materials for biology courses, recommend the use of a colorimeter for measuring enzyme activity, concentrations of reaction products and pigments etc. A significant number of school biology departments probably do not currently have suitable colorimeters for these particular applications, many of which are intended to generate results suitable as evidence for assessment of Outcome 3. These are, broadly, as follows:

- The chemical nature of the plasma membrane [1]
- Induction of the lac operon in *E coli* [2]
- The inhibition of catechol oxidase by lead [3]

(For more detailed curricular references see the end of this article).

Colour charts v. colorimeters

In these circumstances it was clearly important that schools and colleges have alternative means by which to carry out these measurements. As a stop-gap colleagues at the SAPS Scotland Biotechnology Education Project have designed colour standards charts for some of these activities. The Higher Still Development Unit (HSDU) has subsequently produced and distributed large numbers of these charts to schools and colleges. Whilst this is an acceptable way round the immediate problem the use of a colour chart is clearly a stopgap measure and a second best educationally when compared to the use of the proper instrumentation.

Recommended models of colorimeter will thus be entries in our new biology equipment list which is currently in preparation. At the moment one model which has performed acceptably for these biological applications is the latest version of WPA's Co75. Along with other makes and models this has been tested also for a number of chemistry applications. Full test reports are currently in preparation. After the suppliers and manufacturers have had an opportunity to comment on drafts, the final reports will be made available to SSERC members. In the interim, results from our biology trials with the Co75 are given here.

Hints and tips

The chemical nature of the plasma membrane

This demonstration relies on the fairly well known use of denaturation by increasing temperature, and a fat solvent, to show respectively that the membrane is made up of protein and lipids. The experimental procedures were carried out as set down in the HSDU documentation.

So as to address a number of reported minor snags, a few small amendments and additions were made to the procedure as originally published. A fourth experimental condition (water at 55°C) was added and filters of wavelengths other than 580/590 nm were trialed.

A number 11 cork borer was used to cut thin discs of red cabbage leaf tissue which were then thoroughly rinsed in water. Note that as originally published the instructions suggest using only three discs per tube and in our trials even six discs seemed insufficient. Therefore four batches each of 12 discs, selected at random, were placed in boiling tubes with: ethanol at 37°C, water at 37°C, 45°C and 55°C. Leakage of pigment through the membrane after fifteen minutes (observed as colour in the surrounding liquid) was measured by reading absorbance in the colorimeter with water as the blank.

A filter with maximum transmission at a wavelength of 550 nm gave a better absorbance reading than the filter recommended originally (580 or 590 nm) - see Table 1. Note however that the optimal filter wavelength may vary depending on the cultivar of red cabbage or even the individual specimen. Greater leakage of pigments was observed and measured at 55°C than at 45°C. The addition of the higher temperature condition better demonstrates the effect of increasing temperature on the proteins of the plasma membrane.

Wavelength	Absorbance for conditions shown			
	Ethanol	Water		
	37°C	37°C	45°C	55°C
550 nm	0.35	0.11	0.15	0.29
580 nm	0.29	0.10	0.12	0.25
590 nm	0.20	0.07	0.09	0.18

Table 1 Results of absorbance for three filter types and four experimental conditions

cont./

Induction of the lac operon in *E coli*

This experiment tests for the presence of the enzyme β -galactosidase under different conditions. ONPG (ortho-nitrophenyl- β -galactopyranoside) is used as a substitute substrate for lactose. The enzyme, β -galactosidase breaks down the colourless ONPG into galactose and o-nitrophenol. The latter is yellow in alkaline solution. The intensity of the yellow colour is proportional to the concentration of this product and can be measured by a colorimeter thus giving a reliable indication of the degree of enzyme action.

The experimental procedure was carried out as described in the HSDU published protocol. The practical guide recommends a filter of maximum transmission at a wavelength of 420 nm but the shortest wavelength available on the WPA Co75 colorimeter is 440 nm. Using this 440 nm filter gave satisfactory results (Table 2 and Figure 1).

Source of enzyme	Absorbance at 440nm at time in minutes				
	0	10	20	30	40
<i>E coli</i> without lactose	-0.06	0	0.04	0.04	0.02
<i>E coli</i> with lactose	0.04	0.5	0.97	1.36	1.6
β -galactosidase (proprietary)	1	1	1	1	1

Table 2 Absorbance (proportional to concentration) due to o-nitrophenol for different incubation periods and enzyme sources. Previously incubated in the absence of lactose *E coli* is at first incapable of producing the enzyme beta-galactosidase.

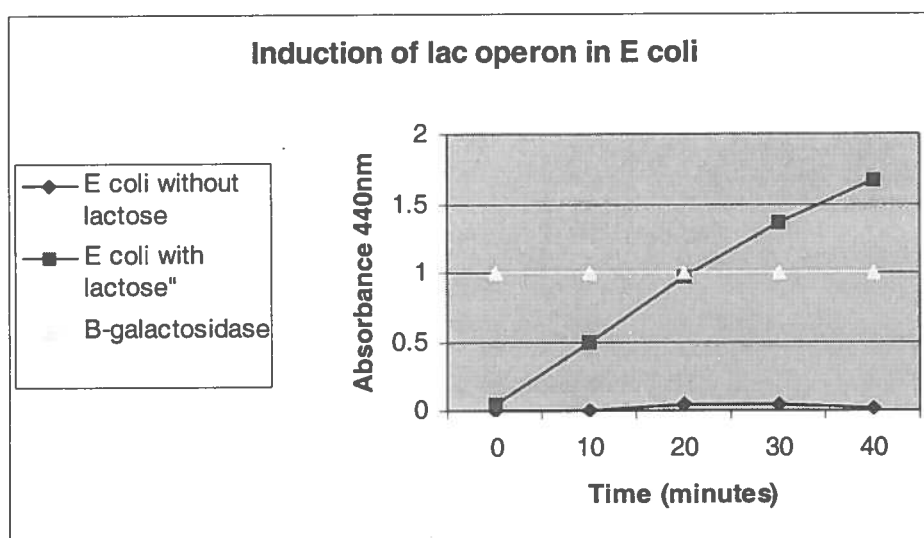

Figure 1 Absorbance versus incubation time for ONPG in presence of three potential sources of beta-galactosidase.

The inhibition of catechol oxidase by lead

Catechol oxidase is an enzyme which is responsible for turning the cut or damaged surfaces of fruits brown. It converts catechol (colourless) to quinone (yellow) which, in the presence of air, is oxidised and then auto-polymerises to give brown or black phenolic complexes.

The experiment investigates the inhibitory effects of lead ethanoate on catechol oxidase extracted from banana. The action of the catechol oxidase is followed by estimating the intensity of colour produced as measured with a colorimeter. The experimental procedure was carried out as per the protocol published by the HSDU.

The practical guide recommends that a colour filter be dispensed with. In our trials this gave poor results. We found that the use of a 440nm filter gave satisfactory results when the colorimeter was reset against the reference solution between measurements (Table 3).

Results

Absorbance at 440 nm	Vol. of lead ethanoate (ml)				
	0	1	2	5	8
	1.04	0.42	0.33	0.07	0

Table 3 Absorbance at 440 nm for catechol oxidase activity with varying amounts of lead ethanoate.

These results are also shown overleaf in graphical form as Figure 2. (Output from Excel. Note that the preferred HSDU format for graphical illustrations tends to be a full grid).

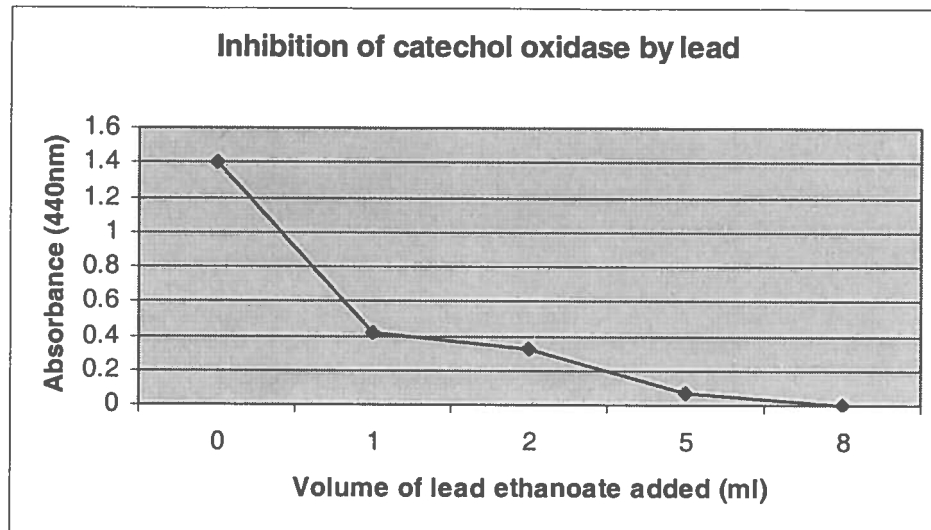

Figure 2 Absorbance at 440 nm for catechol oxidase activity with varying amounts of added lead ethanoate. (Graph output from Excel - spot the software generated 'errors').

Summary of amendments

The following changes should be made to the three sets of procedures :

1. Chemical nature of the plasma membrane :

- Increase the number of tissue discs from 3 to 12 per tube;
- Use a 550 nm filter rather than 580 or 590 nm;
- Add a third temperature - 55°C.

2. Induction of the lac operon :

- Use a 440 nm filter (or nearest value you have to that) if a 420 nm filter is not available.

3. Inhibition of catechol oxidase

- Ignore the suggestion not to use a filter.
- Use a 440 nm filter or the nearest value to that.

Acknowledgements

We are grateful to Mairi Wilson, who was employed in SSERC over the Summer, for carrying out the benchwork described here. Mairi is now a second year undergraduate at Dundee Medical School. We also acknowledge Kath Crawford of Stevenson College who drafted this article from Mairi's notes.

Curriculum references

1. *The chemical nature of the plasma membrane* : See Biology, Cell Biology Unit: 'Cell structure in relation to function' (Higher practical 7 in the Higher Still Development Unit {HSDU} support materials) and Human Biology, Cell Function and Inheritance Unit: 'Cell transport' (Higher practical 11 in HSDU support materials).
2. *Induction of the lac operon in E coli* : See Biology, Control and Regulation Unit: '*Genetic control*' (Higher practical 26 in HSDU support materials).
3. *The inhibition of catechol oxidase by lead* : Biology, Control and Regulation Unit: '*Control of Development, Environmental Influences*' (Higher practical 28 in HSDU support materials) and Human Biology, Cell Function and Inheritance Unit: '*The role of enzymes in cell metabolism*' (Higher practical 18 in the HSDU support materials).

SSERC website

We have taken our website in-house. The URL is :
www.sserc.org.uk

Over recent weeks we have designed a new homepage with members' and visitors' sections. As a temporary measure, we've assigned a generic member user name and password. As usage grows we shall issue schools or individual teachers and technicians with unique user names and passwords. Meantime recipients of the Bulletin may access the members' section by completing the on-screen dialogue box as follows:

User Name : [www/member](http://www.sserc.org.uk) Password : 1707

SAPS secondee

At the turn of this year, the Steering Group of the SAPS Biotechnology Education Project Scotland, will be advertising for a seconded biology teacher. The person appointed will succeed Rodger MacAndrew who will be returning to Queensferry High School. Teachers interested in applying for a two year secondment to the project, hosted by Edinburgh University, are advised to keep an eye out for the advert(s) which should appear in January 2000.

SAFETY NOTES

New fire precaution regulations

The Fire Precautions (Workplace) Regulations 1997 were introduced on the 1st of December 1997 so as to implement the 1989 EC Framework and Workplace Directives. The 1997 regulations applied to around one million workplaces which were not holding a valid Fire Certificate. This meant that employers in such premises needed to carry out a fire risk assessment. These 1997 Regulations, in turn, have now had to be amended.

The Amendment

The European Commission objected to the 1997 regulations on the grounds they did not apply to workplaces already holding a valid Fire Certificate. The UK Government responded to the EC's objections by publishing the Fire Precautions (Workplace) (Amendment) Regulations. These amended Regulations were laid before Parliament on the 7th of July this year and come into force on the 1st of December 1999.

The Impact of the Amendment

The Amendment makes it a requirement for *all workplaces* (other than Special Premises, which are regulated by the HSE) to carry out a fire risk assessment (for which written evidence is required). This is the case even if the premises already hold a valid Fire Certificate. If the findings of the fire risk assessment differ from the requirements of that certificate, a "legislative overlap" is created and advice from the enforcing authority will then be required. The local Fire Brigade is deemed to be the enforcing authority. Whilst brigade fire prevention officers may be willing to advise and assist it is our understanding that officers will not carry out fire risk assessments, which are a matter for employers.

Steps in a Fire Risk Assessment:

The process comprises of the, by now familiar, five steps :

- 1 Identify the Hazards.
- 2 Decide who could be harmed.
- 3 Evaluate the Risks - are existing measures adequate?
- 4 Record your findings.
- 5 Review and Revise.

Training and advice

Some of the specialist fire protection companies and other related suppliers have been offering reasonably priced training courses. A member of the centre staff has already attended one such briefing on the Regulations and we are currently looking again at the details of our own arrangements. We hope then to be in a position to offer further advice to member schools and colleges.

Reference

1. *The Fire Precautions (Workplace) (Amendment) Regulations*, 1999, HMSO.

Hydrogen-oxygen explosions

Some time ago we were asked to carry out a safety audit on some Higher Still Support Notes for Chemistry (Higher). These were entitled *The Hydrogen Economy* [1] and had been written by Dr Wilson Flood. We tried out some of the practical activities and provided safety advice for inclusion in the final published version of the booklet. We were somewhat disturbed to find an additional suggestion for the supply of a hydrogen-oxygen mixture. This suggests the use of a glass Winchester bottle as a reservoir for a two-to-one mixture of hydrogen and oxygen (last paragraph of text on page 12, Figures 6 and 7 on page 13 of the Support Notes).

This method seems to have been added after we last saw the text, it was not in Wilson Flood's original nor added by him at a later stage. We would stress that in our view the glass Winchester method is unsuitable for this type of school based activity. The scale is inappropriate: the risks accompanying the preparation and holding of such volumes of the two-to-one mixture in a glass vessel are significant and disproportionate to the educational benefits. The soap bubble or balloon methods, as originally described by ourselves and Dr Flood, more than adequately cover the need for a dramatic demonstration.

Reference

1. *The Hydrogen Economy*, Higher Still Chemistry Support Notes [Higher], Dr Wilson Flood, SCCS, 1999, ISBN 1 85955 838 0.

* * *

New safety management standard

The British Standards Institution (BSI) has published *OHSAS 18001* [1], a specification document in an Occupational Health and Safety Assessment Series. *OHSAS 18001* was developed to be compatible with both of the international standards intended to deal with Quality (ISO 9001 : 1994) and Environmental (ISO 14001 : 1996) management systems. It came into effect in April of this year.

BSI states that *OHSAS 18001* was developed as an urgent response to demand from its customers for a recognisable occupational health and safety management system standard against which their management systems can be assessed and certified. *OHSAS 18001* and the accompanying implementation guidelines (*OHSAS 18002*) should be of interest to anyone with responsibility in any of the relevant areas of management (environment, quality, health and safety). It is important to note that the *OHSAS* series are not in themselves British Standards and they will be withdrawn at such time as their content is published in either an International or British Standard proper.

Reference

1. *Occupational health and safety management systems Specification*, *OHSAS 18001:1999*. BSI, ISBN 0 580 28298 8.

EQUIPMENT NOTES

Gas law experiments : Part 1

A review of methods for showing the ideal gas laws $V - p$, $V - T$ and $p - T$, including test reports on gas law apparatus. There is a comparison of the relative efficacies of methods with and without computers. The review will be published in two or three parts. This first part looks at ways of showing Charles' Law.

This is a review of the gas law experiments and apparatus. Much of the stuff is old hat. Most of the experiments researched and apparatus tested are, if not quite as old as the hills, as old as anyone of us can remember. Nonetheless we have found difficulties with many methods. Unsurprisingly we found that if a rough and ready approach is taken, the results tend to be poor. However the results can be improved greatly by attending to detail. Much of this article consists then of information on good practice.

For instance there would seem to be a widespread misconception about where to place the thermometer in the pressure-temperature law experiment [1]. If it is sited badly, then the errors are gross.

Some of the methods for showing Charles' Law use mercury. Yes, mercury is hazardous! But tak tent! The risk of harm in these experiments is perhaps one thousand times lower than the risk of breaking your crown on descending a flight of stairs!

Unusually for Bulletin articles, apparatus test reports are incorporated into the experimental reports. We have, while researching the gas laws, examined and tested most of the gas law apparatus on sale from educational suppliers. The proof is in the pudding, as they say. By giving you the actual results from each piece of equipment, you should be able to see from direct comparison how each fares in practice.

Does the company STE mean anything to you? They are importers of inexpensive science apparatus, most of which comes from a South African manufacturer. STE do not sell direct to schools, but distribute their products to intermediary companies such as Griffin, Hogg, Commotion, Rapid and others. You are bound to have noticed STE products in catalogues, the characteristic mark being an uncommonly low price for science apparatus. For the first time we have tested some STE products. Some of our findings are reported below and other will follow in forthcoming issues.

Some of the apparatus under test was computer based. It is unusual to compare computer based methods with traditional ones. But why not? There is a topical debate as to what constitutes a good use of ICT in science teaching. It was one of the main themes at this year's Institute of Physics Education Group's annual conference.

The other side of this question is the exposure of poor practice. The litmus test must be that ICT is only worth using if it improves the quality of education. Does it demonstrably do so in this context? We shall see!

A question we have been asked of late is whether there exists, or could be built, a single piece of equipment with which the three ideal gas laws could be shown. Well there is already on the market an ideal heat engine which purports to do just that. Having tested it and thought about how it works we have concluded that it would not be practicable to design and build equipment to satisfy this request.

Analytical method

The following note describes how different experimental methods and apparatus were compared.

Ordinarily the gas laws are analysed by drawing graphs. Boyle's Law data is expected to give a straight line graph through the origin for p against $1/V$. The other two laws are expected to give straight line fits between either V or p versus T . When the line is extrapolated, it should cut the temperature axis at -273 °C, give or take a few degrees.

The data has been analysed with the LINEST facility in Excel to see whether a straight line fits comfortably through the points. If so, with Boyle's Law data, we have looked to see whether the line fits through the origin; with the temperature laws, through -273 °C. LINEST calculates the standard error in the intercept where the best fit, straight line cuts the axis. By multiplying the standard error by 2 we get the standard uncertainty expressed to a confidence limit of approximately 95%.

If we were stating a scientific result we would not be justified in applying uncertainties and confidence limits that apply for data fitting to a straight line to other data read off an extrapolated line. However because our metrological purpose is the comparison of procedures, and we have no interest in stating a scientific result, we are justified provided that we apply the same analytical method to every sample.

In analysing Boyle's Law results, if the uncertainty overlaps the origin, we have experimental agreement.

Similarly in the temperature laws, if the uncertainty overlaps -273 °C then we have found agreement with the accepted value of absolute zero.

If the results do not agree with the accepted values, or if they agree but the uncertainties are large, or if they only just agree, then there is an indication that the method has systematic errors (Figure 1 - facing page).

Furthermore by comparing the uncertainties of the results from different methods or apparatus we have quantified the doubt incurred by each method. By this means we are able to judge the performance of one method against the others.

cont./p.22

COMMENT : Measurement agrees with the accepted value. There would seem to be no significant systematic errors. Random errors are very small. Both method and apparatus would seem to be good.

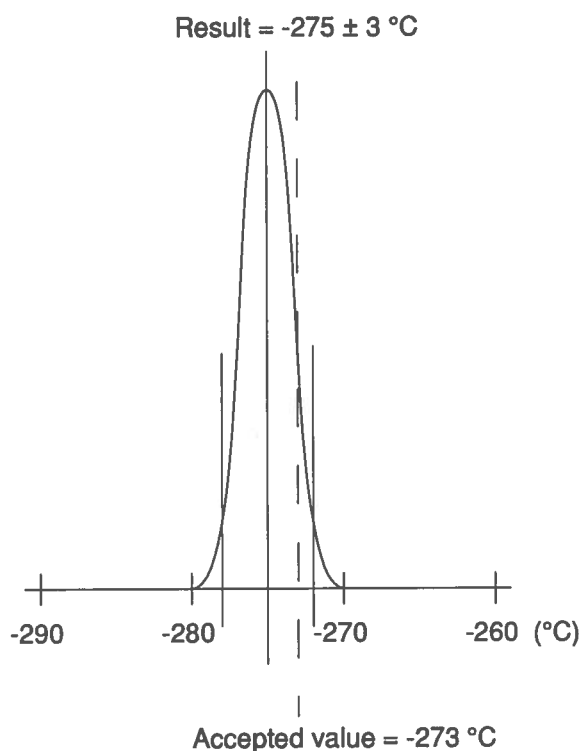

COMMENT : The result does not agree with the accepted value. There is a systematic error, but the random uncertainty is fairly small. The method or apparatus is unsatisfactory.

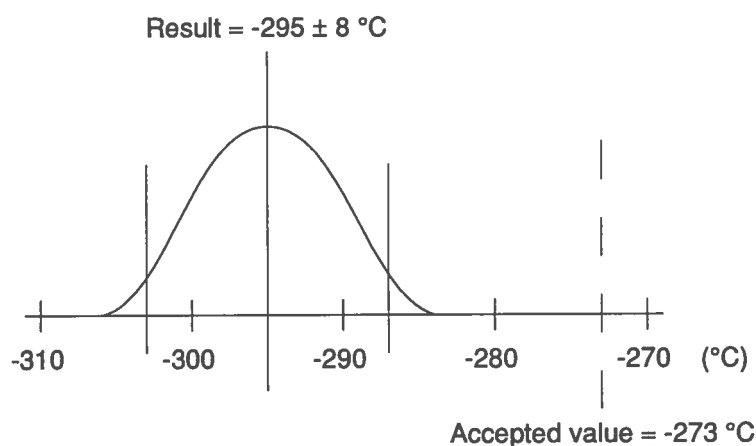

COMMENT : Measurement agrees with the accepted value but the large uncertainty indicates that there is a lot of doubt attached to the result. There is a high probability of systematic errors because of that uncertainty and the wide disparity between the measured and accepted values. The method and apparatus are tolerably satisfactory, but might be improved.

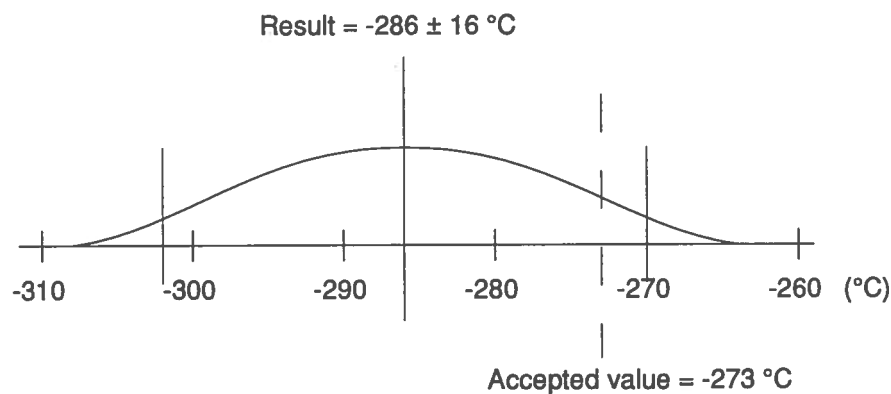

Figure 1 Comparison of methods depends on the distribution of measurements about the accepted value of absolute zero.

Charles' Law

General advice

- 1 The entire air chamber must be immersed in the water bath.
- 2 Minimize the water bath volume to avoid spending too much time heating. For most of the methods described here, a tall form, one litre beaker should be used.
- 3 Use a mercury in glass thermometer, 300 mm long, with a range 0-100 °C.
- 4 Start with the water bath cold and gradually warm it up. (We have seen a description which recommends starting with a hot bath and letting the water cool down. Have they tried it? It takes far too long!)
- 5 Maximize the range by starting at roughly 5 °C and finishing at about 99 °C. To get a litre of water at 5 °C, let the cold tap run until the water is as cold as it will get, then add ice. In summer, you may need a whole tray of ice. Otherwise leave bottled water in the fridge overnight to chill.
- 6 Heat the water bath to raise the temperature by amounts of at least 10 °C. By using steps of this size you will get ten or eleven data points, which is ample to establish collinearity. If you are pressed for time, steps of 20 °C will give you six data points, which is adequate.
- 7 After heating the water bath by roughly the set amount, remove the Bunsen and stir vigorously while the apparatus equilibrates. The waiting period should lie between one and two minutes at temperatures below 70 °C, but only one minute at 70 °C or above.
- 8 Stir well while reading the thermometer.
- 9 If the air chamber in the Charles' Law apparatus is tubular and ungraduated, end effects may cause a systematic error. This error does not affect the linearity or gradient of the V-T graph, but does alter the offset. It can result in the value of absolute zero obtained from the experiment to be in error by 30 °C or more.

Result label	Apparatus type	Additional specification	Result
1	Capillary tube	Mercury	-286 ± 16°C
2		Mercury	-280 ± 8°C
3	Capillary tube	Acid	-295 ± 8°C
4		Acid	-282 ± 6 °C
5		Acid	-281 ± 4°C
6	Griffin	Mercury	-274 ± 6 °C
7		Acid	-275 ± 3 °C
8	PASCO	Heat Engine	-466 ±32°C
9			-438 ± 70°C
10	Philip Harris	Uncorrected	-301 ± 24°C
11		Uncorrected	-298 ± 6 °C
12		Corrected	-262 ± 24 °C
13		Corrected	-259 ± 6 °C

TABLE 1 Summary of Charles' Law methods and results

The reported expanded uncertainties shown in Table 1 are based on a standard uncertainty multiplied by a coverage factor $k = 2$, providing a level of confidence of approximately 95%.

Capillary tube method

The simple method with a thread of mercury in a capillary tube works satisfactorily provided that attention is paid to detail.

The tubing is borosilicate glass with an overall diameter of 6 mm and a bore diameter of 0.8 mm. The end being sealed must be checked by examination under a microscope. Most of the tubes we had prepared were found to have a very fine passageway extending from the bore to the tip that had not been visible under a magnifying glass. Clearly if the seal is imperfect, the tip should be reworked in a hot Bunsen flame. After the tube is judged to be sealed, the glass should be annealed by playing the tip in a yellow flame for about a minute.

The optimum type of beaker is the one litre capacity tall form type. With the beaker depth being 175 mm and a water depth of 160 mm, the capillary tube length should be 190 mm. With these dimensions, the air column should be completely submerged when the water bath is boiling (Figure 2 opposite).

The two fluids used in our trials were mercury and concentrated sulphuric acid. Both gave satisfactory results, but because the acid column invariably split on cooling, the preferred fluid is mercury. (A split fluid thread does not affect the performance, but may confuse the users.) To get a thread of mercury into a tube, warm the tube in an oven whose temperature is set to around 200 °C. When suitably hot, place a small beaker of mercury on a workbench beside the oven. Wearing heat resistant gloves, open the oven and quickly dip the open end of the tube in the mercury. A thread of mercury will immediately enter and rise up the bore as the glassware quickly cools. When the thread is about 12 mm long, remove the tube from the mercury and leave to cool on a mat.

The only adequate ruler material we have found is stainless steel. Perspex rulers warp whereas the scales on wooden rules become unreadable after immersion in boiling water. A 150 mm steel rule is adequate for this method provided that it is attached by elastic bands to a supporting rod which is held in a clamp.

The bore tapers towards the sealed end, causing a systematic error. See Figure. 3, facing page, which shows a longitudinal section through the bore of the capillary tube. Having seen that the taper on a particular tube appeared to extend to about 10 mm, its apparent diameter was measured with a travelling microscope every millimetre from the end of the bore to the part where the diameter was unreduced. The extent of the taper was 16 mm overall. Analysing its effect, the volume of this tapered section would occupy a tube of uniform bore diameter of 9 mm length. Thus if the end of the taper had been set to the zero mark on the ruler, readings of volume would be systematically in error by 7 mm times the cross-sectional area. Uncorrected, its effect would be to depress the estimated value of absolute zero by 18 °C. Having looked at a small number of capillary tubes, the one analysed was the worst. It may then set a bound for the effect of this error on the capillary tube method. It also explains why the value of absolute zero from this method is usually on the low side.

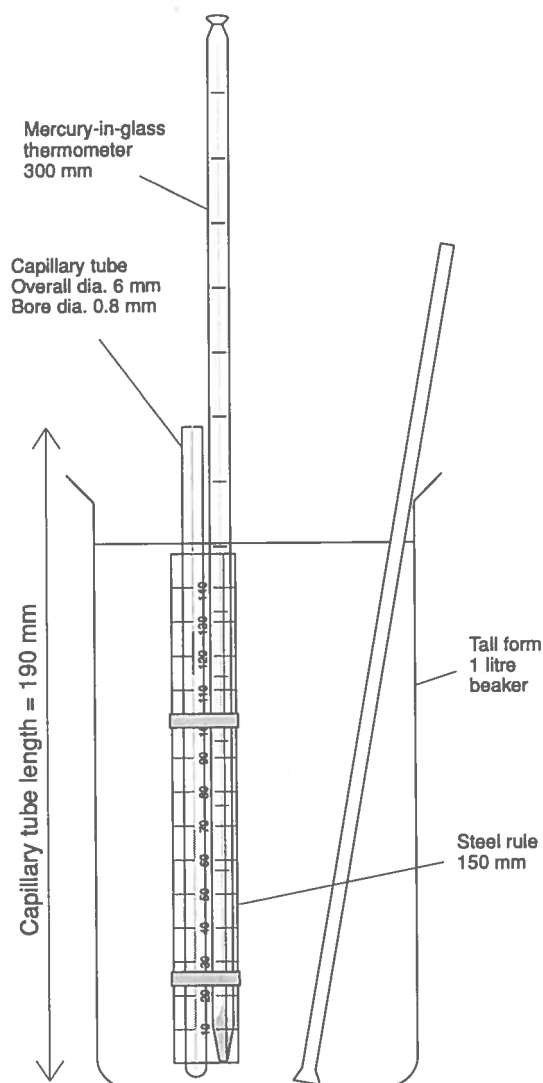

Figure 2 Capillary tube with mercury thread and thermometer, mounted on a steel rule.

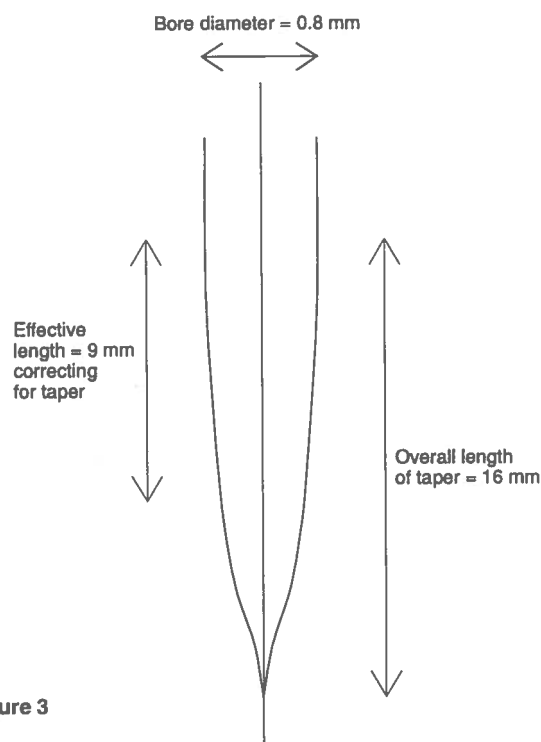

Figure 3

Commenting on the results (Table 1 page 22), they are all affected by the systematic error caused by the bore constricting gradually at its foot. Result 3 is the only one that has been analysed and was in error by 18 °C. If result 3 is corrected, its value becomes -277 ± 8 °C, in comfortable agreement with the accepted value.

That the uncertainties are smallish is indicative that the data points fit quite closely to the best fit straight line. In other words, they show convincingly that there is a linear relationship between volume and temperature. The capillary tube method is thus shown to be satisfactory.

Mercury risk

To assess the release of mercury into the atmosphere from a capillary tube, the length of thread was measured with a travelling microscope before and after immersing the tube in boiling water for one hour. With the volatility of mercury at 100 °C being 280 times greater than it is at room temperature, this was considered to be a worst case test.

There was no discernible loss of mercury under such conditions. The uncertainty in our measurement to a 95% confidence limit was ± 0.3 µg. From this value, if ten tubes were to be immersed in boiling water for one hour, and presuming that the laboratory were to be ventilated by opening windows to give four air changes an hour - a fair assumption with ten Bunsens and beakers of boiling water - the average concentration of mercury vapour in air resulting from this practice would not exceed 0.003 µg per cubic metre of air. Such a concentration would be about 10,000 times lower than the OES. For comparison, the average daily intake of mercury from all sources is between 5 and 10 µg.

Griffin Charles' Law Apparatus

The specialised apparatus from Griffin (Cat. number XHF-550-R : £29.65) gives excellent results with mercury or concentrated sulphuric acid as the fluid trapping the air. The respective values for absolute zero with 95% confidence limit uncertainties are -274 ± 6 °C and -275 ± 3 °C. Both are in staggeringly close agreement with the accepted value. Along with the small uncertainties, they indicate that there are no significant, systematic errors.

The method relies on a high quality, graduated, glass vessel containing the air under test (Tube C - see Figure 4 overleaf). Markings range from 25 ml to 35 ml with divisions of 0.2 ml. One observer read volume to one quarter of a division, or 0.05 ml. Another read to half divisions, or 0.1 ml. At worst, the resolution is one part in 250 of the total air volume.

The fluid which traps the air in Tube C also rises up Tubes A and B. Since Tube B is open to the atmosphere, the fluid height in B must be kept equal to the height in C. This is achieved by adjusting the air pressure in Tube A by means of the rubber tubing with pinch clips, either by releasing a little air out of Tube A, or pumping a little more into it. Because the operator may require a little time practising the technique, it is recommended that the method is tested before the start of a lesson.

We found that the levels of Tubes B and C do not have to be exactly equal. Provided that they are within 5 mm of each other, the error in C is insignificant.

Allow for an hour, at least, to obtain a set of readings.

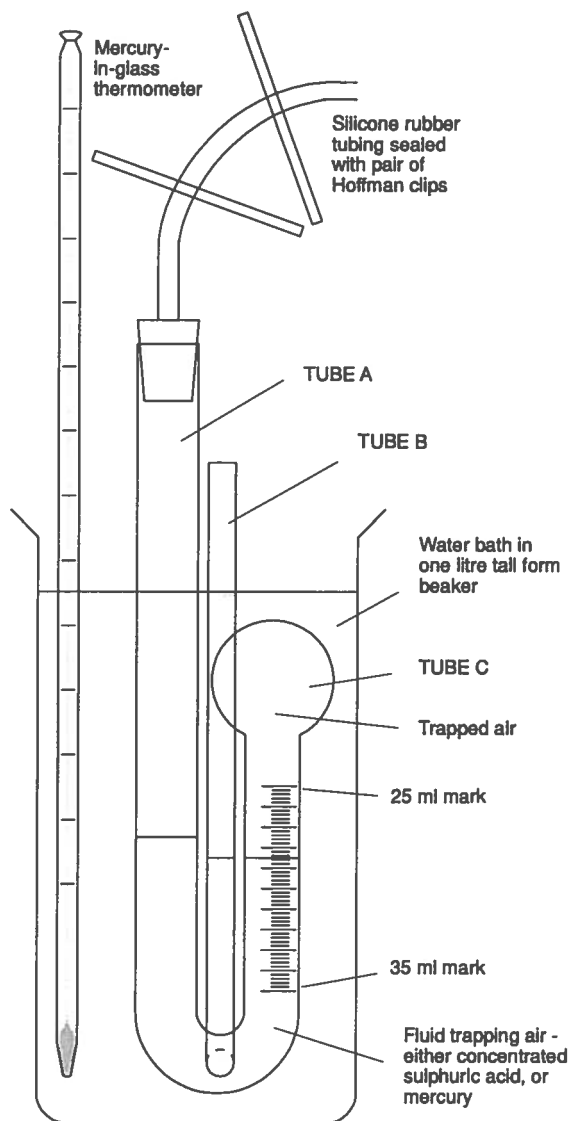

Figure 4 Griffin Charles' Law Apparatus in water bath

Risk assessment

Regarding the risks, it is Hobson's choice as to working with acid or mercury. To take a reading, the observer has to view the gradations from close range. At some stage in the procedure, the water bath should contain water just below the boiling point. Because the water bath is a tall form, one litre beaker, its high centre of mass does put it at risk of being knocked over accidentally. The main risk to the experimenter is that of being scalded. There may also be a risk of acid burns.

If acid were being used and the specialised glassware broke while immersed in the beaker, much heat would be generated which may cause acidified water to spurt from the beaker. If mercury were being used and the glassware broke or couped, the impact of mercury falling from a height would probably scatter it outwith the bounds of a mercury tray.

With either type of fluid the experimenter must wear eye protection to protect against splashing and spurting. The apparatus should be set up on a mercury tray if mercury is being used. Also the room should be well ventilated. With most S5 classes, the experiment should be demonstrated by the teacher, but not performed by children. However it is tolerably safe for pupil use in project work in S6.

PASCO Heat Engine

This apparatus (Cat. Number TD-8572 : £278) can show all three gas laws, but does not meet with our first criterion for Charles' Law apparatus that the entire air chamber must be immersed in the water bath. With this apparatus, there are two connected air chambers (see Figure 5, facing page). The fixed volume canister of 90 ml is immersed in a water bath whereas the variable volume cylinder with low friction piston is not. The cylinder has an internal diameter of 32.5 mm and length of 100 mm, making its maximum volume to be 83 ml. The interconnecting tubing, which also is not in the water bath, has a volume of 3 ml.

Although well engineered to have low friction, air can leak past the piston either into or out of the system. This may not be significant in a Charles' Law demonstration because the enclosed air should remain at atmospheric pressure throughout.

Results 8 and 9 (Table 1 page 22) show that the Heat Engine is unsuitable for a quantitative exposition of this law.

Harris Charles' Law Kit

The apparatus is referenced as Q32480/4 and costs £38.98. It comprises of a glass J-tube connected by rubber tubing to an oil reservoir (Fig. 6). The enclosed air is trapped within the shorter arm of the J-tube by oil. It is kept at atmospheric pressure by maintaining the oil level in the J-tube at the same level as the level in the beaker. The J-tube is immersed in a tall form, 3 l beaker of water. Because the air chamber is ungraduated, a steel rule was attached by elastic bands acting as a scale.

The apparatus was found to be awkward to prepare. Initially a pipette pump was used to draw air into the tube. Finding this to be impracticable, oil was then drawn in with a 100 ml gas syringe. The task took two people a half day to accomplish, which was unreasonably long. Moreover, on completing our tests, while trying to remove the rubber tube, the glass tube was broken, indicating that the apparatus is fragile.

Because of the height of the apparatus, to immerse totally the air column in a water bath, the size of beaker needed is three litres, of the tall form variety. The thermal inertia of this volume of water is such as to take about 90 min to heat from 5 °C to 100 °C, leaving time to interrupt heating to take readings. Thus it would be scarcely practicable to undertake a full set of readings with the Charles' Law Kit in a normal, school science, double period.

Results with the apparatus (10 and 11 Table 1 p.22) did not agree with the accepted value, showing there there seemed to be one or more large systematic errors. Two sources of systematic error were considered :

- tapering of the tube below the stop cock;
- vapour pressure of water and oil in trapped air.

Because the tube was ungraduated, we had initially presumed that the air column volume was proportional to its height. Over most of its length, the tube diameter is 7 mm approximately. About 23 mm beneath the tap, the diameter reduces to about 5 mm. Just beneath the tap it reduces further.

cont./page 27

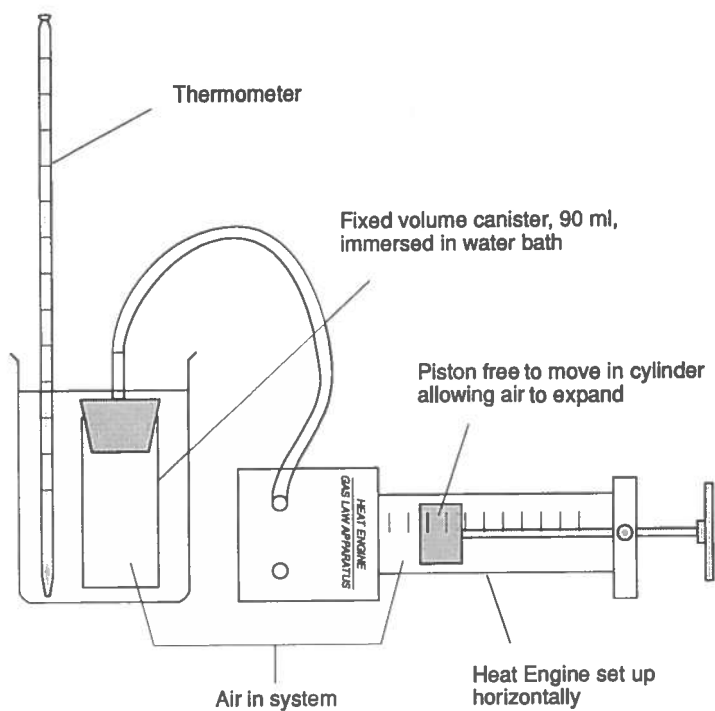

Figure 5 PASCO Heat Engine set up to show Charles' Law

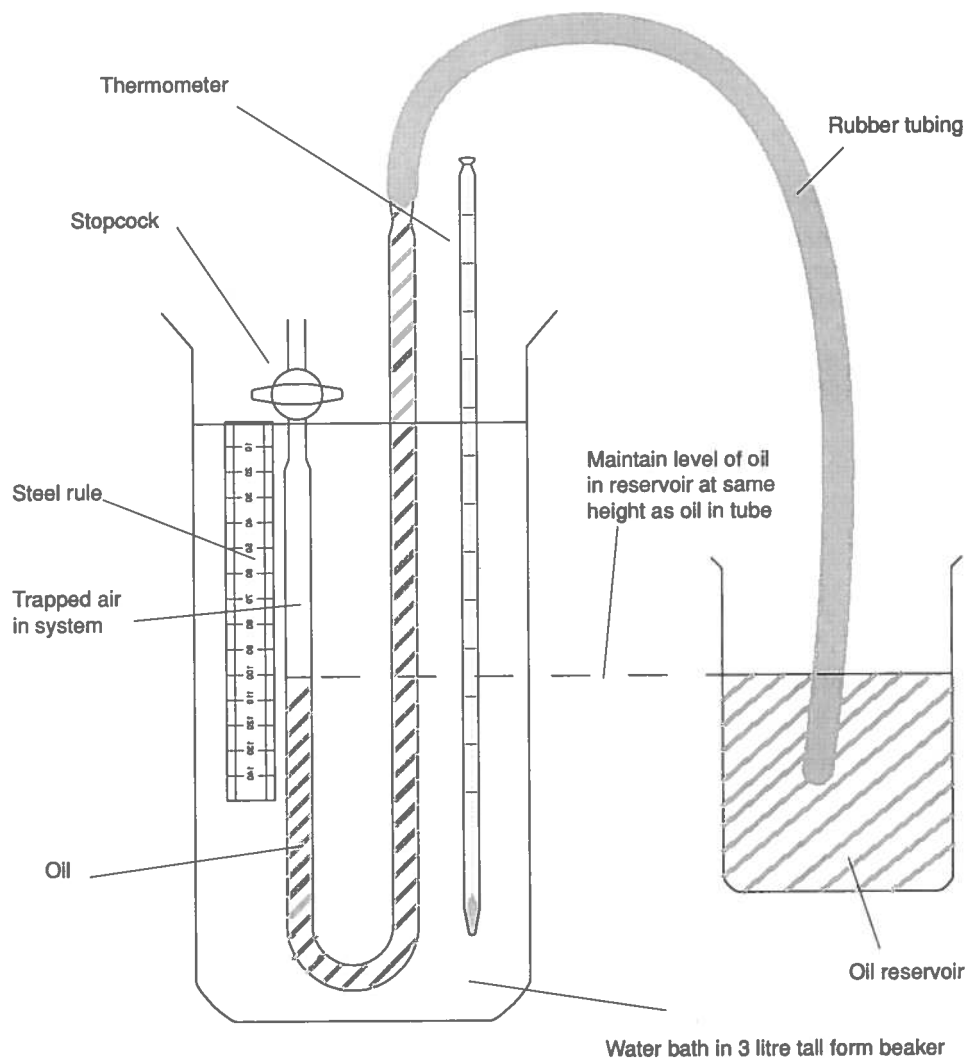
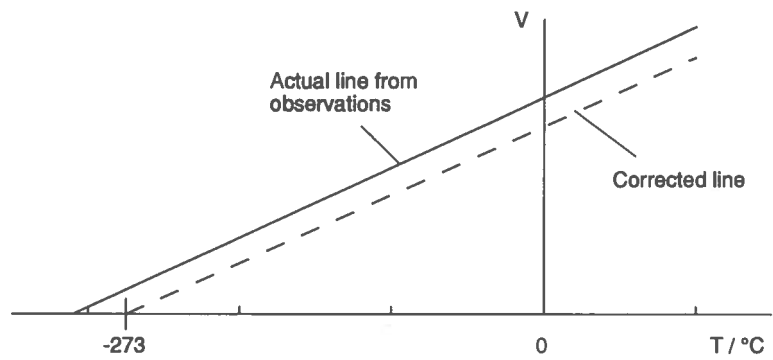

Figure 6 Experimental arrangement with Harris Charles' Law Kit

CAUSE OF ERROR : End effects

EFFECT : Values of volume are offset by an error. Results in the value of absolute zero being too low.



CAUSE OF ERROR : Incomplete immersion

EFFECT : At high temperatures, air expands less than would happen if the entire air chamber were immersed in the water bath. Results in the value of absolute zero being too low.

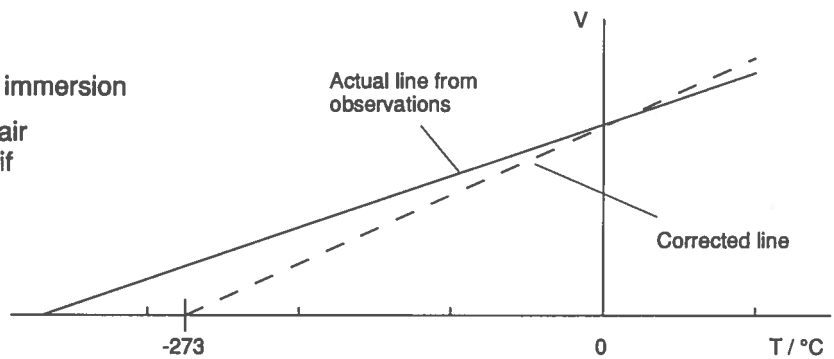

CAUSE OF ERROR : Vapour pressure

EFFECT : If air not dry, or if there is oil vapour, then at high temperatures the vapour pressure causes the air to expand a little further. Results in the value of absolute zero being a little too high.

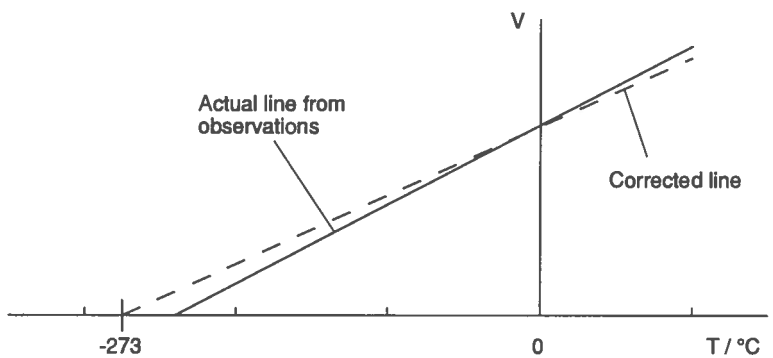

CAUSE OF UNCERTAINTY : Random and systematic effects

EFFECT : Creates doubt in the value of absolute zero.

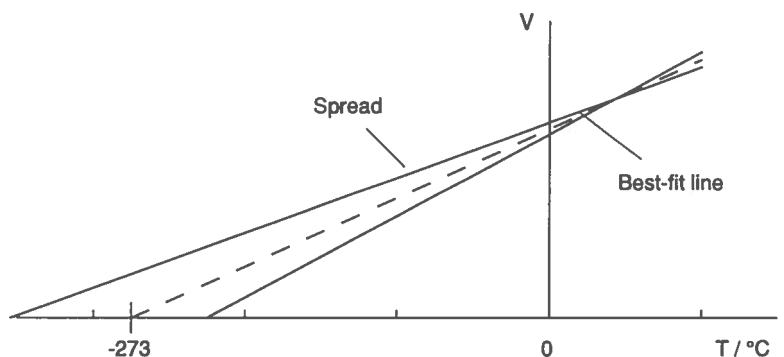

Figure 7 Effects of errors and uncertainties on the Charles' Law experiments

Considering these effects, measurements of column height are systematically too large by 12.2 mm. Correcting for this error shifts the place where the V - T line cuts the $V = 0$ axis by about 40 °C. Results 12 and 13 have been corrected for this error.

However the fact that the corrected results are too high now indicates that there may be an error caused by vapour pressure. Because such an error would be more extreme with high temperatures, that would make the actual gradient through the data to be steeper that it would be for dry air. Since the corrected results (12 and 13) lie about 12 °C above the accepted value (-273 °C), it would seem that the results had been affected by vapour pressure.

Because it is awkward to fill, fragile and performs poorly, we do not recommend the Harris Charles' Law Kit.

We understand that Harris have removed their other Charles' Law apparatus (Q32500/6) from their product range.

STE Charles' Law Apparatus

This apparatus is available from Hogg (Cat. Number XPG040.10 : £125). The apparatus consists of a *Jolly Bulb* connected by about a metre of flexible tubing to an open glass tube. The tubing is filled with mercury trapping air in the bulb. The bulb is immersed in a water bath. The open tube is raised or lowered to maintain the air pressure at atmospheric.

We have not been able to test this apparatus because the Jolly Bulb was found to be broken on delivery. However we would not expect it to perform well because a considerable part of the enclosed air is in tubing which is outside the water bath. On theoretical grounds, the design would seem to be poor.

Schools' Laboratory Equipment

This Charles' Law apparatus is referenced as 400/10 and priced at £10. It consists of a capillary tube 190 mm long with mercury bead as per SSERC's specification above. The tube is mounted on a plastic back-plate to which is attached a 150 mm plastic ruler. Because the ruler has a softening point at about 90 °C, the water temperature should not be taken above 80 °C. The back-plate has holding clips for a 150 mm thermometer.

The apparatus can be supplied with an unfilled capillary tube (400/11 at £9.50 a unit) for filling at school with mercury or sulphuric acid. SSERC has not tested this equipment because it appeared on the market after this review had been prepared.

Errors and uncertainties

Some of the more common sources of error are summarized in the set of hypothetical graphs in Figure 7 opposite.

It is presumed with the first three graphs that only one error is acting. The effect of such an error on the resulting value of absolute zero is shown. With many of the methods outlined above, two or more errors were acting, either in unison, or opposition.

The fourth graph depicts the effect of uncertainties in the readings. Sources of uncertainty, as well as consisting of random effects, may also include other systematic effects not hitherto identified. For some sets of readings, the uncertainty can be reduced by taking more measurements, improving the measuring instrument, waiting for the item being measured to stabilize, or improving the skill of the operator.

Conclusion

This Bulletin issue has carried a review of methods and apparatus for showing just one of the ideal gas laws, Charles' Law. The analytical method used in the evaluation has been explained.

Future issues will review methods and apparatus for showing the pressure-temperature law and Boyle's Law. They will include a critical examination of the use of ICT in experiments, comparing computer-based methods with traditional ones. Finally, there will be comment on the ideal apparatus concept with which, if it existed, all three gas laws might be shown.

Acknowledgement

We are grateful to Nicola Jones, now a final year physics undergraduate at Edinburgh University, who was employed in SSERC over the Summer. Nicola carried out much of the benchwork for the evaluation and processed many of the results described here.

Reference

1. *Activities 20A and 20B : Relationship between pressure and temperature of a fixed mass of gas at a fixed volume* : Physics Higher : Higher Still Support Materials, HSDU, 1998.

* * *

ODDS AND ENDS

Trade News

Air Compressors

Many of the businesses that were originally supplying the educational market with pneumatics equipment and services have now left the market place. A lot of the personalities and 'characters' associated with those companies have moved on and changed jobs. This has left not a few schools without any contact with educational pneumatics suppliers for spares or servicing. However there are still one or two companies who will undertake inspection and servicing of all types of air compressors. Bob Thomson, lately of compressor manufacturer Amprotech, recently visited us, he is now with Cable Pressure Systems.

Those schools still involved with pneumatics in Standard Grade Technological Studies may have compressors well past their 10th anniversary. Although those with receivers under 250 bar/litres are deemed exempt from full inspections, there may be problems with pressure regulators, pressure gauges and airlines. After a decade of oil-filled air flowing through them, they may well be, to use a technical term, gunged up. Their performance could be then impaired. Receivers could probably benefit from an internal clean and inspection to ensure there are no signs of corrosion.

The exempt models (less than 250 bar/litres) most commonly found in technical departments are:

Amprotech75/25/VSS; Bambi72/250 and Junair 6-X

The problems highlighted in the preceding paragraph also apply to non-exempt compressors. But they will perhaps have had regular inspections every 2 years or so by the local authority's insurers and should have had internal examination of the receivers.

Models with receivers operating at greater than 250 bar litres and commonly found in schools are:

Amprotech75/50/HMS; Bambi 150/500; Junair 12-50

* * *

Microscope servicing

"With regard to your (Trade News) article in Issue 195, Autumn 1998, on microscope servicing I would like to inform you of a company in Glasgow (Microscope Sales and Servicing) which offers a microscope maintenance service. They also supply new and second-hand microscopes. We have been using them for many years and feel that others in the area may wish to use a local service".

We have in the past also recommended this Glasgow firm for consideration. We are grateful to the school for confirmation that they offer a quality service.

* * *

Technical tip

Sodium flames - again

We keep getting enquiries about sodium flame pencils. These, we suspect, stem partly from fairly recent publications which mention flame pencils even though for some time they have been nigh on impossible to source. They remain a demand therefore for simple methods of getting a sodium flame. Previous issues [1,2] have described methods for producing flame coloration from sodium and other sources, with the throwaway suggestion of heating filter paper soaked in a salt solution. This note expands on using soaked paper.

If a 12.5 cm diameter piece of filter paper is folded in half four times making a 12.5 cm taper, soaked in brine and held in a hot Bunsen flame with tongs, the paper burns with a sodium flame for a little over 7 minutes. When the last of the ash falls out of the tongs, the tongs themselves continue to colour the flame yellow for several more minutes.

Better performance was found by rolling two circles of filter paper into a tight cylinder. When this was soaked in brine and held in a retort stand with the spill at an elevation of ten degrees it burned with a 13 cm to 15 cm tall flame for a period of 80 minutes. The sodium D emission lines were picked up with a hand spectroscope at a range of 10 metres, indicating the strong, luminous intensity of the source. After burning brilliantly for 40 minutes, the brightness slowly diminished during the second 40 minute period.

This simple method is recommended as a satisfactory substitute for the pencil, now obsolete and unavailable.

References

1. *Methods for producing flame coloration*, SSERC, Bulletin 129, 1981, 6-7.
2. *Sodium flame pencil substitute*, SSERC, Bulletin 175, 1992, 38.

* * *

Quick reviews

Safe and Exciting Science : A Pack of Training Activities on Health and Safety for Science Departments in Secondary Schools and Colleges and for Initial Teacher Training. A collection prepared by a Task Group of ASE's Safeguards in Science Committee. This pack has been designed for maximum flexibility in delivery within the institution itself. Useful for short sessions in departmental meetings, PAT activities, tutorials half day courses etc. Intended for delivery by staff based in the establishment itself. From ASE Booksales at £12.50 per pack of masters. Recommended.

Effective Teaching of Science : A Review of Research. This is a super wee book and more of its kind could go a long way toward getting teachers interested in applying some results of action research in their labs and classrooms. It's a mercifully slim volume, written with great economy and elegance by Professor Wynne Harlen. It's also a suitable valedictory effort - marking her recent retirement from SCRE. The distillation of such a huge spread of recent research in science education is remarkable. The booklet covers : practical work; using ICT; changing pupils' ideas; reflection and metacognition; assessment as an aid to learning; planning, questioning and language; the curriculum and improving teachers' own understanding. Buy it - SCRE publication 142, ISBN 1 860003 048 3, £9.50.

EQUIPMENT NOTES

Robot wars - gearboxes

A visit from grandchildren made me aware of a television programme named *Robot Wars*. This is probably less violent than Tom and Jerry but only marginally so. The idea of a remotely controlled machine which can enthuse young children seems a good idea, however, particularly as an introduction to Technological Studies in S1/S2. *Robot Wars* could even exert a motivational influence, yea even unto Standard Grade and maybe even on into Higher Still and applications of the BASIC Stamp.

Apart from being good fun (always one of our primary aims) robotics does enable a teacher to introduce concepts such as, torque, centre of gravity, simple and compound gearboxes, the choice and use of materials, and

application of design criteria, to name but a few of a host of possibilities. Rather than pupils attempting to destroy each other's robot buggies, a tug of war could be organised or an obstacle course designed to evaluate agreed criteria.

All of the foregoing is but a long-winded way of introducing a note on recent evaluations of a number of inexpensive gearboxes, all under £5.00, which could be incorporated into the design of a robot buggy.

Gearboxes presently on offer, range from a simple worm and gear to multi ratio boxes. We have tried a variety of the inexpensive models; and our findings are set out in the table below.

TYPE	RATIO	SUPPLIER PART NO.	COMMENTS	COST
worm & gear	42:1	JPR 450-044	Inexpensive but needs a little fitting and tweaking	0.95 (no motor)
multi-ratio kit with motor	5:1 to 1125:1	Rapid 37-1220	Full instructions with mounting plates but fiddly	£3.90 each
multi-ratio kit with motor	5:1 to 1125:1	Opitec 224.105	As above	£2.10 each £19.50 10pk
solar-drive kit dual ratio	9:1 or 27:1	Opitec 124.166	Full instructions, simple to assemble but only for light duty. Will drive a buggy/crane from solar cell(s).	£1.45 each
ring system with motor	4:1 to 256:1	Teaching Resources TG1 020	Full instructions with novel design. Pivot holes have to be reamed before assembly.	£28.80 per box of 10
Universal gearbox with motor	See comments	Teaching Resources PAC 1501	Full instructions with mounting plates. Needs some care during assembly. Output shaft can be positioned to change gear ratio. Should only be operated on 3 V else torque at higher voltages may result in stripped nylon gears.	£1.70 each or £16.00 per 10

Each of the gearboxes has some form of frame to enable it to be easily mounted onto a model. If we were to choose a best buy the ring gearbox would just be ahead, namely for ease of assembly. The solar drive is compact; providing good torque for a solar buggy but the motor supply should not exceed 3V.

Should you have need for a specific output speed then the universal is the next best. However pupils in S1/S2 may have difficulty in both assembling this gearbox and tweaking the assembly to make it run smoothly. A little light grease in the gearboxes helps in smooth running.

Equipment Offers

Items are arranged by similarity of application, or for other reasons, and not by stock number sequence. Often the item number serves only for stock identification by us in making up orders. Newer stock items are underlined, so as to be more easily seen.

VAT : The prices quoted do not include VAT. However it is added to every customer's order. Local authority establishments will be able to reclaim this input VAT.

Postage : Postage and, where necessary, packing, will be charged for. It is therefore best not to send cash with an order, but wait for us to bill you. Official orders may be used.

Please try and ask for at least £10 worth of goods because the administrative costs of handling orders are significant.

Don't send cash with orders We repeat, please do not send payment with your order. Wait until you receive our advice note upon which payment may be made. This saves unnecessary complications, e.g. when items are out of stock, failure to make provision for VAT, or if a delivery charge needs to be made. Items of equivalent value may be deducted from your order to balance any shortfall.

Motors

- 778** Stepper motor, Philips MB11, been stored in damp conditions but unused and retested. 4 phase, 12 V d.c., 100mA per coil, 120W coil per phase, stepangle 7.5°, with 7 mm x 2mm dia. output shaft. Dimensions 21mm x 46mm dia. on oval mounting plate with 2 fixing holes, diam. 3 mm, pitch 42 mm, at 56mm centres. Circuit diagram supplied. £2.50
- 755** Pulley wheel kit comprising: - plastic pulley wheel, 30mm dia., with deep V-notch to fit 4mm dia. shaft, - two M4 grub screws to secure pulley wheel, - Allen key for grub screws, and - 3mm to 4mm axle adaptor. The whole making up a kit devised for SSERC tachogenerators with 3mm shafts. Specially supplied to SSERC by Unilab. £1.25
- 848** Motor, 12 V d.c., no load current 2 A at 12 V and 1.5 A at 5 V. Min. no load starting voltage, 2 V, min no load running voltage 0.8 V. 64 X 37 mm dia., shaft, 11 X 3 mm dia. £2.50
- 614** Miniature motor, 3V to 6V d.c., no load current 220mA at 9600 r.p.m. and 3V, stall torque 110mNm, dims. 30mm x 24mm dia., shaft 10mm x 2mm dia. 45p
- 593** Miniature motor, 1.5V to 3V d.c., no load current 350mA at 14800 r.p.m. and 3V, stall torque 50mNm, dims. 25mm x 21mm dia., shaft 8mm x 2 mm. 30p
- 739** Miniature motor, 1.5V d.c., dimensions 23mm x 15mm dia., shaft 8 mm x 1.7 mm dia. 25p
- 621** Miniature motor, 1.5V to 3V d.c., open construction, ideal for demonstration, dimensions 19 x 9 x 18 mm, eight tooth pinion on output shaft. 25p
- 839** Motor, solar, 12 mm long by 25 mm dia., shaft 6 x 2mm dia. (see also Item 838 - solar cell). £1.70
- 773** Tachometer (ex equipment) £2.25
- 811** Worm and gear for use with miniature motors, 34 : 1 reduction ratio plastic worm and gear wheel. 35p
- 378** Encoder disk, 15 slots, stainless steel, 30 mm dia. with 4 mm dia. fixing hole. 80p
- 642** Encoder disk, 30 slots, stainless steel, 30 mm dia. with 4 mm dia. fixing hole. 80p
- 772** Encoder disk, 4-bit Gray code, stainless steel, 81.28 mm dia., 3 mm fixing hole, slots sized to register with components mounted on 0.1" stripboard. Applications: shaft position sensing, wind direction indicator. For related electronic circuitry see Bulletin 146. £3.00

Precision motor stock

- 785** Precision motor with optical shaft encoder, 0.25 to 24 V d.c., no load current and speed 9 mA and 6,600 r.p.m. at 24 V, stall torque 23 mNm, 9 segments. Overall body length including shaft encoder 59 mm, dia. 23 mm with output shaft 20 x 3 mm dia. Back EMF constant 3.6 V/1000 r.p.m. Suggested application - tachogenerator. Data on shaft encoder section available on application. £15
- 787** Precision motor with attached gearbox, 0.15 to 12 V d.c. With a supply of 3 V, the no load current is 25 mA and the output shaft turns at ca. 20 r.p.m. Gearbox ratio 1 : 365. Overall body length including gearbox 43.5 mm and diameter 16 mm. Output shaft 6 x 3 mm dia. with flat side to maximum depth of 0.3 mm along outer 5 mm length of shaft. Application - any system where a very slow angular velocity is required. £15
- 836** Motor mounts, plastic push-fit with self adhesive base pad, suitable for SSERC motors 593 & 614, pk of 10 £1.95
- 801** Propeller, 3 blade, to fit 2 mm shaft, 62 long. 35p
(Replaces Item 791 at lower cost).
- 792** Propeller kit with 10 hubs and 20 blades for making 2 or 3 bladed propellers. 130 mm diameter. Accepts either 2 mm or 3 mm shafts. £3.40
- 790** Buzzer, 3 V. 55p
- 827** Buzzer, 6 V. 55p
- 821** Reducer, 3 mm to 2 mm, enables gears, pulleys and wheels to be fitted to motor shaft, per 5 25p
- 867** Reducers, as above but 4mm to 2mm, pack of 5 25p
- 868** Ditto, 4 to 3mm 25p
- 846** Sound module, includes 'melody' chip and Piezo transducer. £1.00
- 710** Sonic switch and motor assembly. First sound starts the motor, a second reverses the direction of rotation, a third sound stops the motor needs 4 AA cells (not supplied) 85p
- 715** Pressure gauge, ca. 40 mm o.d. case, 25 mm deep and 33 mm dia. dial reading 0 to 4 bar (i.e. above atmospheric). With rear fitting for 1/8" BSP. Suitable for use as indicator for pneumatic circuits in Technological Studies. 75p

cont./over

Components - semiconductors

807 Schools' Chip Set, Designed by Edinburgh University. The 4 chip set comprises: Resistors; MOSFETs; Diodes and Optoelectronics, and ring oscillator. £6.00

Single replacement chips £2.00 per chip:

871 Chip 1 - Resistors

872 Chip 2 - MOSFETS

873 Chip 3 - Diodes & Optoelectronics

874 Chip 4 - Ring oscillator

322 Germanium diodes 8p

701 Transistor, BC184, NPN Si, low power. 4p

702 Transistor, BC214, PNP Si, low power. 4p

717 Triac, Z0105DT, 0.8 A, low power. 5p

725 MC74HC139N dual 2 to 4 line decoders/multiplexers 5p

699 MC14015BCP dual 4-stage shift register. 5p

711 Voltage regulator, 6.2 V, 100 mA, pre-cut leads. 10p

Sensors

615 Thermocouple wire, Type K, 0.5 mm dia., 1 m of each type supplied: Chromel (Ni Cr) and Alumel (Ni Al); for making thermocouples, see Bulletins 158 and 165. £3.10

640 Disk thermistor, (substitute type) resistance of 15 k Ω at 25°C, b = 4200 K. Means of accurate usage described in Bulletin 162. 30p

641 Precision R-T curve matched thermistor, resistance of 3000 Ω at 25°C, tolerance $\pm 0.2^\circ\text{C}$, R-T characteristics supplied. Means of accurate usage described in Bulletin 162. £3.00

718 Pyroelectric infrared sensor, single element, Philips RPY101, spectral response 6.5 μm to >14 μm , recommended blanking frequency range of 0.1 Hz to 20 Hz. The sensor is sealed in a low profile TO39 can with a window optically coated to filter out wavelengths below 6.5 μm . Data sheet supplied. For application see SG Physics Technical Guide, Vol.2, pp 34-5. 50p

503 Kynar film, unscreened, 28 μm thick, surface area 12 x 30 mm, no connecting leads. £1.00

504 Copper foil with conductive adhesive backing, makes pads for unscreened Kynar film to which connecting leads may be soldered. Priced per inch. 15p

506 Resistor, 1 gigohm, $\frac{1}{4}$ W. £1.40 Optical and opto-electronic devices
838 Solar cell, 100 x 60 mm, 3.75 V per cell max. £2.10

507 Optical fibre, plastic, single strand, 1 mm dia. Applications described in Bulletin 140 and SG Physics Technical Guide Vol.1. Priced per metre. 50p

508 LEDs, 3 mm, red. Price per 10. 50p

761 Ditto, yellow. Per 10. 60p

762 Ditto, green. Per 10. 60p

858 Flash bulb older type (getting difficult to source) for UV triggered reactions in chemistry. Pack of 5. 85p

Economy variable volume micropipettors

Of slimline profile, these micropipettors are fully autoclavable (121°C max.). They have a nominal accuracy of $\pm 1.75\%$. Supplied with spare O-ring and lubricant. Tip ejector swivels, thus pipettors are suitable for either left- or right handed users. Colour coded bodies for ease of identification. Supplied with two tips and stocks of spare tips available. Three sizes :

849 micropipettor, 1 cm³, range 100 to 1000 μl £16.00

850 micropipettor, 5 cm³, range 500 to 5000 μl £16.00

851 micropipettor, 10 cm³, range 1000 to 10,000 μl £16.00

Replacement tips in packs of 25 tips :

852 replacement tips for 1 cm³ micropipettor, pack. £1.50

853 replacement tips for 5 cm³ micropipettor, pack. £1.70

854 replacement tips for 10 cm³ micropipettor, pack. £2.15

Other items for Higher Practicals:

859 Eppendorf tubes, 1.5 cm³, for use in TEP/SAPS/NCBE microcentrifuge, pack of 50 85p

860 Nylon mesh for protoplast isolation/fusion protocol, 70 μm pore size, per 305 mm square. £7-00

Pipette fillers

863 0-2 cm³ pipette filler (Pi pump type), each £5.75

864 0-10 cm³ as above £5.75

865 0-25 cm³ as above £5.75

Items not for posting

The following items are only available to callers because of our difficulties in packing and posting glass items and chemicals. We will of course hold items for a reasonable period of time to enable you to arrange an uplift.

768 Sodium lamp, low pressure, 35 W. Notes on method of control available on application. 85p

810 Watch glasses, assorted sizes 20p

712 Smoke pellets. For testing local exhaust ventilation (LEV) - fume cupboards and extractor fans : large, 50p, small, 40p

* * *

SSERC, St Mary's Building, 23 Holyrood Road, Edinburgh, EH8 8AE. Tel: 0131 558 8180, Fax: 0131 558 8191,
Email: sts@sserc.org.uk

SSERC Website: www.sserc.org.uk Members' site : Current user name: www/member Password: 1707

ASE (UK,HQ), College Lane, Hatfield, Hertfordshire, AL10 9AA. Tel: 01707 283000, Fax: 01707 266532, Website: www.ase.org.uk

ASE Booksales, College Lane, Hatfield, Hertfordshire, AL10 9AA. Tel: 01707 283000, Fax: 01707 266532,
Email: timbarrett@ase.org.uk Website: www.ase.org.uk

ASE Scotland, Dr Susan Burr (Secretary), Newbarns, 18 Holding, Mainholm, Ayr, KA6 5HE. Website: www.asescotland.org.uk

Blades Biological Supplies, Cowden, Edenbridge, Kent, TN8 7DX. Tel: 01342 850242, Fax: 01342 850924,
Email: info@blades-bio.co.uk

BSI Standards, 389 Chiswick High Road, London, W4 4AL. Tel: 0181 996 9001, Fax: 0181 996 7001.
Email: info@bsi.org.uk Website: www.bsi.org.uk

Cable Pressure Systems Limited, Barrowmeadow Road, Springkerse Estate, Stirling, FK7 7UW. Tel: 01786 449292, Fax: 01786 449393.

Commotion, Unit 11, Tannery Road, Tonbridge, Kent TN9 1RF Tel: 01732 773399, Fax: 01732 773390.

Economatics (Education) Ltd., Epic House, Darnall Road, Attercliffe, Sheffield, S9 5AA. Tel: 0114 281 3311, Fax: 0114 243 9306.

Griffin & George, Bishop Meadow Road, Loughborough, Leicestershire, LE11 5RG. Tel: 01509 233344, Fax: 01509 231893,
Email: griffin@fisher.co.uk

Philip Harris Education:

2 North Avenue, Clydebank Business Park, Clydebank, Glasgow, G51 2DR. Tel: 0141 952 9538.

Novara House, Excelsior Road, Ashby Business Park, Ashby-de-la-Zouch, Leicestershire, LE65 1NG.

Tel: 01530 418000, Fax: 01530 418016, Website: www.philipharris.co.uk/education

Higher Still Development Unit, Ladywell House, Ladywell Road, Edinburgh, EH12 7YH. Tel: 0131 314 4620, Fax: 0131 314 4621.

HMSO: The Stationery Office Limited, 51 Nine Elms Lane, Vauxhall, London, SW8 5DR. Tel: 0171 873 0011, Fax: 0171 873 8247.

Hogg Laboratory Supplies: listed under Scientific & Chemical Supplies Limited.

JPR Electronics, Unit M, Kingsway Industrial Estate, Luton, Bedfordshire, LU1 1LP.

Tel: 01582 410055, Fax: 01582 458674, Email: sales@jprelec.co.uk Website: www.jprelec.co.uk

Microscope Sales and Servicing, Netherton House, Anniesland Village Business Park, Netherton Road, Glasgow, G13 1EU.
Tel/Fax: 0141 954 8844.

Milford Instruments, 120 High Street, South Milford, Leeds, LS25 5AQ. Tel: 01977 683665, Fax: 01977 681465.

OPITEC Education Materials Limited, 7 West Road, Woolston, Southampton, SO19 9AH. Tel: 01703 446515, Fax: 01703 446991.

PASCO Scientific, PO Box 619011, 10101 Foothills Boulevard, Roseville, California, USA, 95661-9011.

Fax: 001 916 786 8905, Email: (Technical support) techsupp@pasco.com Website: www.pasco.com

UK distributor: Instruments Direct Limited, Unit 4, Brentford Business Centre, Commerce Road, Brentford, TW8 8LG.

Tel: 0181 560 5678, Fax: 0181 232 8669.

Rapid Electronics, Heckworth Close, Severalls Industrial Estate, Colchester, CO4 4TB. Tel: 01206 751166, Fax: 01206 751188,
Email: sales@rapidelec.co.uk

SAPS, Homerton College, Cambridge, CB2 2PH. Tel: 01233 507168, Fax: 01223 215004, Website: www.saps.plantsci.cam.ac.uk

Schools' Laboratory Equipment, 1 Loch Place, South Queensferry, EH30 9NG. Tel/Fax: 0131 331 1955,

Email: Schools_Lab@compuserve.com

Scientific & Chemical Supplies Limited, Carlton House, Livingstone Road, Bilston, West Midlands, WV14 0QZ.

Tel: (Scotland) 01236 449669, Tel: (England & Wales) 01902 402402, Fax: 01902 402343, Email: scs@scichem.co.uk

Scottish Council for Research in Education (SCRE), 15 St John Street, Edinburgh, EH8 8JR.

Tel: 0131 557 2944, Fax: 0131 556 9454, Website: www.scre.ac.uk

STE UK Limited, 137 John Wilson Business Park, Whitstable, Kent, CT5 3QY. Tel: 01227 263636, Fax: 01227 273363.

Teaching Resources, Middlesex University, Trent Park, Oakwood, London, N14 4YZ. Tel: 0181 447 0342, Fax: 0181 447 0340.

Technology Teachers' Association: Lorna Nicolson (Secretary), 3 Conifer Place, Lenzie, Glasgow, G66 4EG.

WPA, The Old Station, Linton, Cambridge, CB1 6NW. Tel: 01223 892688, Fax: 01223 894118.

