

SCOTTISH SCHOOLS EQUIPMENT RESEARCH CENTRE

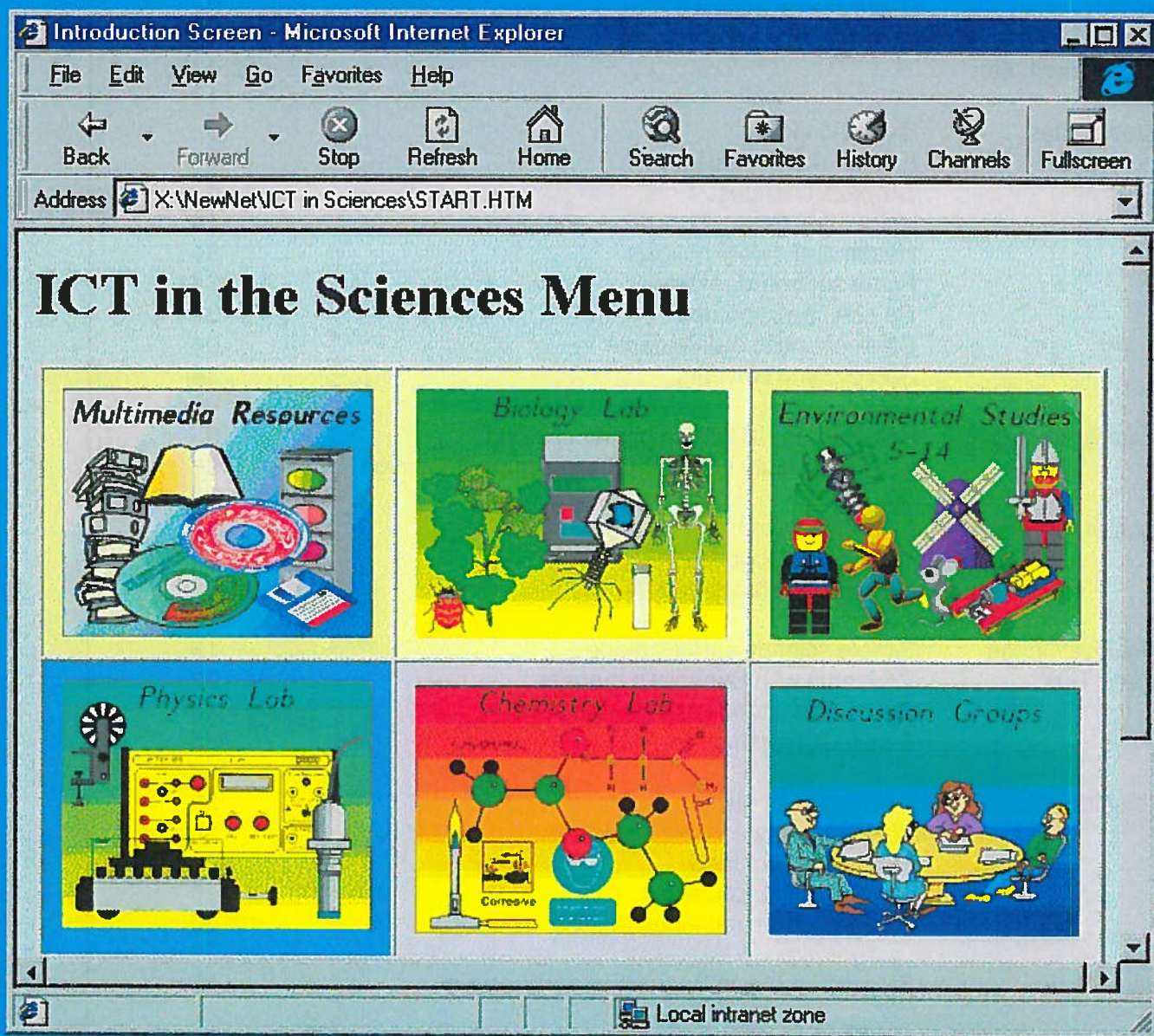

Science & Technology Bulletin

For: Teachers and Technicians in Technical Subjects and the Sciences

ISSN 0267-7474
Number 196

Spring 1999

Science and Technology Bulletin

Number 196 Spring 1999

Introduction		1
Opinion	IT butters no turnips?	2
No comment, etc		2,33
Safety Notes	Extension leads	3
	Lasers, more misuse	4
	<i>Six pack</i> changes	4
	Solder flux fume	26
	Health and safety policies	34
	Fume cupboard testing	34
	<i>Be safe!</i> (re)reprinted	34
	Clear phenolic disinfectants	34
	Snorers and solvents	34
Feature Articles	SSERCNet - ICT Development News	5
	SSAG Advisory Notes - ICT in Science Education	9
Equipment Notes	Projectile launcher	14
	New pupil oscilloscope	20
	PASCO interfaces and the iMac	33
Technical Notes and Tips	Simple science surfer's guide	13
	Problems with Benedict's reagent	22
	MOSFETs, diodes and photodiodes	30
	Simple light gates	36
Biological bits	Development officer	25
	Sixth year tips	25
	- effects of lead	
	- ideas for projects	
	POST report summaries (again)	25
Trade News	Stop press : Irwin Desman in receivership	37
Equipment Offers		38

© SSERC 1999

ISSN 0267-7474

Copyright is held to be waived only for bona-fide educational uses within current Scottish member EAs, schools and colleges.

The *Science and Technology Bulletin* is published by SSERC, St Mary's Land, 23 Holyrood Road, Edinburgh, EH8 8AE. Telephone: 0131 558 8180, Fax: 0131 558 8191, Email: sserc@mhie.ac.uk Web site: <http://www.vtc.scet.com/links/sserc/>

Managing Editor: John Richardson. **Cover illustrations :** Front - ICT in the Sciences menu, part of the STS/SSERC Website currently under development. Rear cover - Fire fighting (nothing new there then) technician members at the ASE Scotland Annual Meeting : © SSERC 1999.

INTRODUCTION

Whoops - missed it!

Remember all that nonsense in Bulletin 195 about issue number 200 being published at or about the millennium. Forget it. We typed too soon. We are now born-again fans of Arthur C. Clarke and shall not be celebrating until 2001. For reasons, rather than excuses, see *Cyber Swans* below.

SSERCyber-swans

Meantime, a major event for us has been the securing of funding for a collaborative project with SOEID to develop a Science on-line Centre. It is to grow out of a feasibility study with which SSERC was earlier involved. This has meant that we have had to upgrade our own ICT equipment and install a PC (Windows NT) network. As you might imagine, not all has gone (is going?) smoothly. It's a learning curve and a half alright this networking business. It is only of some slight consolation that this stuff of nightmares may yield useful advice to schools and others on snares, delusions and technical traps for the unwary.

One such delusion leads to unqualified claims that information technology improves productivity and saves on paper. Not straight-off it don't. While we are guddling about in network (mis)management it's odds-on that there will be short to medium term disruption of some aspects the service. To begin with, enquiries may take a wee while longer to turn round and paper based publications are already being delayed.

The other ICT initiative with which we've more recently got involved is *SETNET* (Science, Engineering, Technology and Maths Network). There are now three SETPoints in Scotland - the Scots founder member was Setpoint North in Aberdeen, a more recent one Setpoint West based in Glasgow and now, latest of the lot, Setpoint East based here in the Lothian Education Business Partnership in Edinburgh. With the support and active encouragement of the Royal Society of Edinburgh, ASE Scotland, the Scottish Science Advisory Group and other interested parties, the three Setpoints are already actively collaborating in the setting up of a national, ie Scottish, SET Network. If you add to all of that activity the SSERC Director's recent appointment to the Steering group of the Scottish Virtual Teachers' Centre you may understand why there was no Winter issue of the Bulletin.

Stay serene, please. Remember, as for teachers with the weans and technicians with teachers (same thing, the latter might claim) - however outwardly calm we look - we're all paddling like hell underneath.

No comment

One to add to the "*I tellt ye. I tellt ye*" quote on all that which is bad in "Scotch Education" [SSERC Science and Technology Equipment News, No.16]?

"We were taught always to expect the worst"

SSERC News - membership etc

We are pleased to announce that, three years or so after Local Government reorganisation, all bar one of the Scottish Local Authorities are now members of SSERC. The Board of SSERC Limited (a Company Limited by Guarantee) which governs our affairs and the staff are particularly grateful to the core of authorities which stood by the Centre, both in the run up to and throughout the early difficulties of reorganisation. We would also like to thank all those teacher and technician clients who argued so strongly for continuation of the service or who have persuaded new councils to join or rejoin the consortium.

The Board and the Company as a whole also owe an enormous debt to the Senior Associates of SSERC. These are staff who left direct local government employment at reorganisation and have worked effectively full-time for SSERC but on part-time salaries. The Centre could not have survived without their dedication and unique contribution.

It's certainly been a tricky three years or so but now that nearly all of the Councils are on board, the first strategic objective of the Board has been achieved. This was first to stabilise and then improve the financial position. The next objective was to recruit some new staff to serve alongside experienced, part-time (so called) senior officers of the Centre. The aim is to achieve some measure of overlap so that new staff have the opportunity to learn from an appropriate Senior Associate before these expert staff enter retirement 'proper'.

New appointment

The first such appointment was made recently. Fred Young, until lately of Lochgilphead High School, Argyll and Bute, has been appointed as Development Officer for Chemical Education at SSERC. Fred hails originally from Perth and is qualified in geology as well as to teach chemistry. He had extensive commercial and professional experience as a geological engineer before training as a teacher. He also spent some time teaching south of the border before returning to Scotland, Fred joined the staff team at SSERC at the beginning of March 1999.

Diary updates

The *Institute of Biology's* fourth annual education day is set for Thursday the 13th of May with the venue again Stirling University.

The *Royal Society of Chemistry's* equivalent shindig for chemists at St Andrews University is to be on Thursday the 20th of May 1999.

The *Institute of Physics* 25th educational huddle gathers also in Stirling University on the 20th of May 1999.

The Annual General Meeting of the *Technology Teachers' Association* (TTA) is set for sometime in October 1999, venue to be announced.

OPINION

Back in the early 'eighties, first learning how to measure accelerations with a Commodore Pet computer, this skill was applied with mixed effect in my own teaching of mechanics in physics courses. On the debit side were : the cumbersome apparatus; lengthy set-up time; teething problems with home-built circuits; the unreliability of low quality, multiway connectors; the capriciousness of the Pet tape cassette reader and the awfulness of the assembly language programs, which were first coded in hexadecimal and then transcribed into decimal.

Like all software, these programs were only ever 99% finished, being in a state of perpetual improvement¹. Physics lessons had an air of espionage - there was always a code book to hand to sort out another muddle.

On the credit side were fun, thrills, spills and the satisfaction at getting direct measurements of acceleration of an accuracy comparable to that which ticker tape might have given. And so this microelectronic wizardry was applied in natural contexts to the syllabus. When this cycled round to dynamics, I remember still my first bash at Newton 2. This was tried out during a free period before the actual lesson. With the usual arrangement of a trolley on a friction compensated slope, the accelerations for one, two and three stretched elastics were 0.17 m s^{-2} , 0.33 m s^{-2} and 0.51 m s^{-2} .

Jubilant at this success of the new technology, I began my computer assisted lesson on dynamics with an air of confidence which, as events were to prove, was sadly unwarranted. The first set of results with the class went something like 0.17 m s^{-2} , 0.23 m s^{-2} and 0.34 m s^{-2} . Suffice to say that no matter how many hooks and crooks were resorted to, we failed to get a series of acceleration readings in the simple ratio of 1:2:3, corresponding with numbers of elastics. There are of course many factors which contrive to make this a difficult experiment. Looking back, the main defect was the use of trolley elastics. Not only is it difficult to extend elastics by the same amount while a trolley is moving, they have such a wide range of sensitivities as to be of little use in quantitative work.

Well some things have improved since the early 80s. With contemporary ICT equipment, we are now able to measure accelerations reliably to a tolerance of 1%. Equipment specifications have improved. 8-bit systems have been replaced by 12 or 16-bit ones working at higher speeds. There is now better software. Systems are generally plug and play, which is to say that you just follow your nose without formal instruction or training.

There are, however, some things which just haven't improved. I'm thinking of trolley elastics. We may have, or are about to obtain, state of the art computers, but do we have state of the art apparatus? How many schools are still using trolley elastics? Why? They are quite awful, except for the most primitive, qualitative exercises. How many schools, for that matter are still using traditional trolleys, Serviscope Minor Oscilloscopes, a Panax scaler, Russian demountable transformers, Jordanhill Circular Motion Apparatus, or a linear air track that fails to give friction free motion and runs off an air blower with an 80 dB noise level preventing oral communication by any means other than shouting?

There is presently quite a buzz about acquiring new equipment. We know of schools where scores of PCs or IMacs have just been delivered. Our enquiry line has lots of teachers asking what to buy or bid for. Ever thought of superseding your trolley elastics? What instruments does your department - even in its chronically under-resourced state - hold? Very probably you have instruments already for measuring time to an uncertainty of $\pm 0.1\%$, velocity to $\pm 0.5\%$, acceleration to $\pm 1\%$, mass to $\pm 0.1\%$, voltage to $\pm 0.5\%$, current to $\pm 1\%$ What you probably don't have is good, basic apparatus with which to apply your instruments! It's no use having accurate instruments unless you also have apparatus with which to make worthwhile measurements - I'm thinking for instance of trolleys which are relatively friction free, a runway which is perfectly linear and means of precisely controlling the accelerating force, with the capacity to get repeatable results.

My other specialist colleagues tell me that things are little different in the other sciences. Many biology and chemistry departments don't have a decent demonstration microscope, a modern autoclave, centrifuge or spectrophotometer or hold even one colorimeter never mind a class set. Serviceable pH or conductivity meters each with a properly responding electrode are similarly like hens' teeth, as are modern, digital instruments generally. It's always worth remembering that computers are not the only 'intelligent' contemporary devices based on microelectronics and microprocessors.

If I had the choice of what to buy, I'd plump for apparatus as well as ICT kit. If I didn't have the choice, but was aware that the purse strings were being untied to bestow equipment on my department, I'd fight for better apparatus. In any event, with every pound of butter, I would ask for several loaves of bread (Oh, - nearly forgot - and the odd turnip or two!).

[Signed : *Baldrick*]

¹ Bob Sparkes, Datalogging Guru at the time, promulgated the 1st Law of Program Debugging which states that "*The time taken to remove any given bug is inversely proportional to the number of bugs which then remain*".

Query : Apropos of very little : Is - "*Scottish Professional Development Programmes for Education*" - an oxymoron?

SAFETY NOTES

In recent weeks we have fielded a large number of relatively minor, yet intriguing, enquiries on health and safety matters. Some of these are judged likely to be of more general interest and our replies are summarised below.

Extension leads

We have had a number of questions raised on the topic of best practice in the use of such leads. In particular we've had enquiries on lengths, ratings and inspection or test procedures. In their code of practice for in-service inspection and testing of electrical equipment published in 1994 the IEE state :

"Where extension leads are fitted with a standard 3-pin socket outlet these should be tested as Class I appliances. Any such extension leads that are found to be without an earth wire should be marked as defective and removed from service.

The length of an extension lead should be checked to ensure that it is not so great that the appliance performance is affected by voltage drop. Additionally the length should not exceed the following :

<i>Core area</i>	<i>Maximum length</i>
<i>1.25 mm²</i>	<i>12 metres</i>
<i>1.5 mm²</i>	<i>15 metres</i>
<i>2.5 mm²</i>	<i>25 metres</i>

Cable reels must be used within their reeled or unreeled ratings as appropriate.

2.5 mm² extension leads are too large for standard 13 A plugs although they may be used with BS 4343 (BS EN 60309-2) industrial plugs. Extension leads exceeding the above lengths should be fitted with a 30 mA residual current device (r.c.d.) manufactured to BS 7071.

Commenting on this IEE guidance :

1. Extension leads with a core area less than 1.25 mm² should be withdrawn from service as soon as may be practicable. They should have the cord replaced with one having an appropriate core area. A check through trade catalogues indicates that most types of extension lead or multiway adaptor are fitted with 1.25 mm² core area cord. It may well be that sub-standard sizes are relatively uncommon.
2. The earth continuity test pass condition for an extension lead is the sum of the nominal cord resistance R plus 0.1 Ω . The IEE have published a table of nominal resistances (TABLE VI) against length for different core areas. An extract is tabulated in the next column. By way of an example, a 12 metre extension lead with a core area of 1.25 mm² has a nominal resistance of 187 m Ω . The pass condition for insulation resistance between the 13 A plug and any 13 A socket-outlet on a multiway adaptor connected to

Length (m)	Resistance (milliohms) (For a given core area)		
	(1.25 mm ²)	(1.5 mm ²)	(2.5 mm ²)
1.0	15.6	13.3	8.0
1.5	23.4	20.0	12.0
2.0	31.2	26.6	16.0
2.5	39.0	33.3	20.0
3.0	46.8	39.9	24.0
4.0	62.4	53.2	32.0
5.0	78.0	66.5	40.0

Table 1 - range of resistance values for cables of a given length and core area

the extension lead should be any value less than 287 m Ω , or 0.29 Ω . Many PAT instrument meters are able to resolve to 0.01 Ω .

3. Cable reels would seem somewhat anomalous. Were we to apply the same rules to them as we do to extension leads, then the minimum core area would be 1.25 mm². However cable reels with smaller core areas, either 0.75 mm² or 1.0 mm², are in widespread use. By not specifically referring to this, the IEE would seem to tolerate their usage. Additional to the caution from IEE to keep within their reeled or unreeled ratings, it would be prudent to restrict their usage as far as possible. Wherever possible use an extension lead rather than a cable reel with an undersized core area.

The earth continuity pass condition is similar to the one given for extension leads. For instance the nominal resistance of 18 metres of 0.75 mm² cable is 281 m Ω , giving a pass value of 380 m Ω .

Summary advice on extension cable usage

1. They should never be installed on a semi-permanent basis as a substitute for fixed-installation socket-outlets, for instance by tacking an extension lead to a wall.
2. They may however be used in temporary installations such as temporary lighting, or an exhibition stand, or powering laboratory equipment where there is a shortage of socket outlets.
3. They may also be used in some circumstances on a semi-permanent basis to provide power to ICT equipment. If used in this type of installation, the manner of usage of the extension lead should be checked periodically to ensure that it is not subject to undue tension, compression, bending, heating, or tampering by children.
4. If an extension lead is taken across a passageway, it should be protected with a walkover device.

* * *

Lasers, more misuse

We have had a report of an incident, in a school in England, wherein a laser had been misused by a group of children who had been left unsupervised in a physics laboratory. We understand that laser radiation was deliberately directed into a staffroom adjacent to the lab exposing a teacher to radiation. The victim suffered temporary loss of vision in the affected eye, with after images persisting for some days. He was medically examined, the results of which indicated that the eye had not been permanently damaged.

Quite astonishingly the class teacher dismissed the incident with a flippant remark to the effect that:

"It was only a Class 2 laser. These are not capable of causing harm."

Commenting on this incident, the very low incidence of laboratory accidents is due largely to a recognition amongst teachers that practical work must be supervised - especially so for special hazards such as working with lasers. There is a specific requirement never to deliberately expose any person to laser radiation. This applies for Class 2 radiation, just as it does for lasers of higher power. There is also a general requirement that if an exposure cannot be avoided, steps must be taken to reduce the radiation intensity to as low a level as may be achievable and this level must be well below the limit for causing harm. Physics teachers need to be aware of these basic safety rules and to heed them.

Laser pointers

Further misuse of laser pointers in general, non specialist, applications should be curbed by guidance issued this year by NRPB. This guidance can be summarized as follows :

1. Laser pointers may be used as a training aid by professional staff in the workplace. However such usage is restricted to Class 1 or Class 2 laser pointers.
2. The use of Class 3B laser pointers up to 5 mW may be justified for some applications in the workplace where the user has received adequate training.
3. The sale of laser products to the general public should be restricted to Class 1 or Class 2 devices and should be sold with instructions to enable the user to operate the product in a safe manner.
4. The DTI has urged Trading Standards Authorities to remove laser pointers of a class higher than Class 2 from the general market.

This guidance from NRPB should have little effect on schools other than to reduce the likelihood of children acquiring dangerously powerful laser pointers.

The current Scottish Office guidance to schools in Circular 7/95 remains in force. Because none of its provisions have been countermanded by this recent NRPB guidance, existing arrangements continue to apply.

* * *

Six-pack changes

The sets of Regulations which make up the so called *Six Pack*, together with the HSE Guidance thereon were first published in 1992. We reported on them in Bulletin 174 [1]. Unusually, at that time, the Regulations and either the Approved Code of Practice (ACoP) or the HSE Guidance were conveniently bound in the same volume. We have carried a number of articles on the *Six Pack* since our first report in August 1992. Nonetheless, on our own health and safety courses and audits - even those held during this current school session - it has been a too common experience to meet teachers, technicians and senior management teams who have never heard anything of this very important legislation. Now, two components of the pack have been revised and re-published in new editions. The individual components of the *Six Pack* are affectionately (?) known by their short form titles. Not uncommonly "Regulations" is truncated to "Regs" :

The Management Regulations;
Workplace (Health, Safety & Welfare) Regulations;
PPE (Personal Protective Equipment) Regulations;
Display Screen Equipment Regulations;
Manual Handling Regulations;
Work Equipment Regulations (PUWER).

It is the last two sets of regulations which have recently been reissued in new editions with revised guidance. Their full, Sunday, names are the *The Manual Handling Operations Regulations, 1992* [2] and *The Provision and Use of Work Equipment Regulations, 1998* [3] respectively. Note that, in the case of the latter legislation, the previous relevant 1992 Regulations have been withdrawn in their entirety. New ones were promulgated with a number of additional requirements to do with mobile work equipment and for work equipment inspection. These new PUWER regulations were needed to implement European Directive 95/63/EC. They came into effect on 5th December 1998. We intend reporting more fully on the changes to PUWER in the next Bulletin issue. Also new is a set of *Lifting Operations and Lifting Equipment Regulations (LOLER'98)*. This last named legislation is unlikely to impinge greatly on mainstream educational practice.

In contrast, it is our belief that the Manual Handling legislation may not be treated as seriously as it deserves in education. HSE figures show that over 36% of all accidents involving injury at work are connected with manual handling operations. We also know that in the educational sector, manual handling accounts for just over 30% of all incidents causing injury.

References

1. *New regulations*, Safety Notes, Bulletin 174, SSERC, August 1992.
2. *Manual Handling, (Manual Handling Operations Regulations, 1992), Guidance on Regulations*, L23, HSE Books, 1998, ISBN 0 7176 2415 3.
3. *Safe use of work equipment (Provision and Use of Work Equipment Regulations 1998)*, L22, HSE Books, 1998, ISBN 0 7176 1626 6.

* * *

SSERCNet - ICT Development News

Centre staff have had to cope recently with major changes in SSERC's information and communications technology. These developments are already leading to new products and have potential for improving SSERC services. Some of that recent development work is reviewed and illustrated. Further possibilities for the future are outlined.

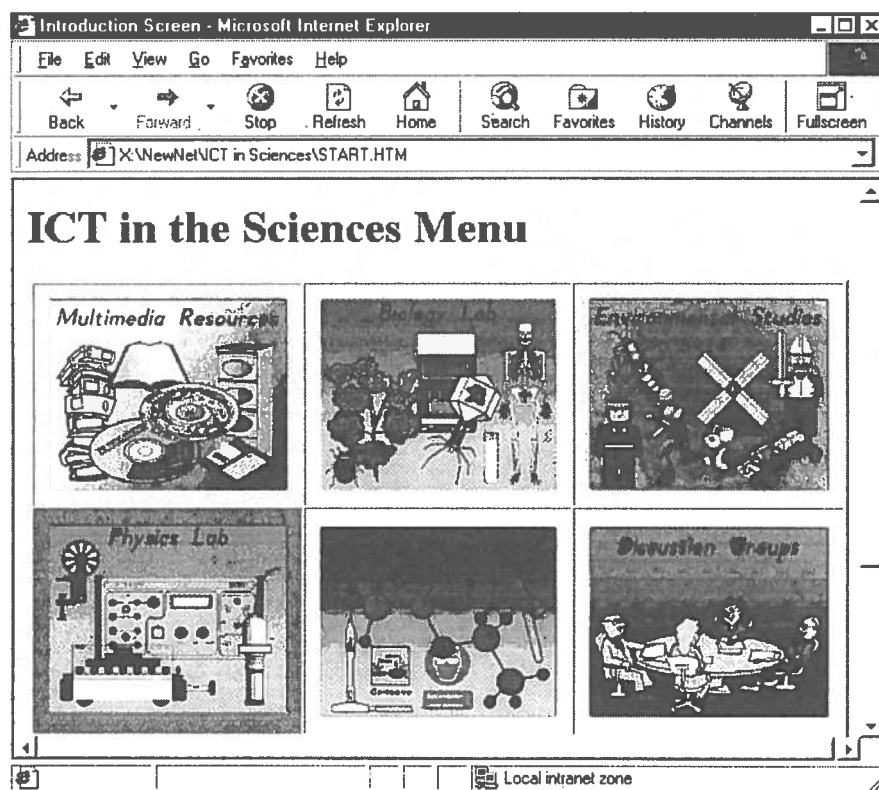

As indicated in the *Introduction* to this issue, much of our effort over recent months has been inwardly directed. We're sorry about that, since it goes against our natural, service-based philosophy. Only in recent weeks did we finally become convinced that all the effort might yet prove worthwhile. That is just as well, given that the current high educational priority given by Central Government to ICT is likely to continue into the Scottish Parliament. Like them or loathe them, ICT networks are the in-things. To surf or swerve? That is the question. Some time ago we decided on a sceptically enthusiastic approach.

Many Scottish schools, both primary and secondary, are either taking delivery of new ICT equipment or are about to do so. Between now and the end of the first term of next session, a lot of them will be connected to some kind of network. Once the attention shifts from kit to content then trustfully teachers will start looking for useful things to do with these new, and relatively expensive, toys.

The use of ICT is not an end in itself. There has to be a significant payback in effectiveness or efficiency, preferably both, if the cost in teachers' time and effort is not to outweigh any benefit in terms of learning and teaching or even in saving on administration. The sincere hope has to be that we won't all simply repeat the ('C-less') cock-ups of the IT initiatives of the '80s. Any chance there is for preserving what little sanity remains for teachers and technicians, may lie with that new bit - the 'C' for "communication". In our own, limited, experience, the effective use of facilities such as Email or the Web is rooted in need. On the one hand is a real demand for some useful information and on the other, someone or some group, with something useful to say. The technology of the medium thus doesn't change the basics of professional engagement. It merely sets them in new contexts. This is the aspect which chiefly has interested us. There is a potential for synergy between existing, people based, educational networks and the new means by which they may communicate and interact. "*The World's your Lobster*" as Arfer Daly was wont to say. (cont./over)

Network projects

SSERC is currently involved in a number of initiatives, either as project manager, or a partner, in collaborative ventures intended to assist in building support networks for science, engineering and technology education. Some of these initiatives are briefly described below.



SOLSN

This is the *Science On-line Support Network*, a joint SSERC and SOEID initiative in collaboration with a small number of Scottish Education Authorities (The City of Edinburgh, Fife and West Lothian Councils). Renfrewshire Council also now have an interest in SOLSN following on their provision of some support material for use in the project. After a feasibility study, managed by the Scottish Interactive Technology Centre and evaluated by the Scottish Council for Research in Education (SCRE), the project is now well into the pilot stage. So as to limit the variables under scrutiny, the pilot project is still relatively small scale in terms of the numbers of schools with only ten primary schools and one secondary being actively involved. An interesting feature of the study is that the secondary and some of the primaries form a *cluster group*.

The aim of the project is to explore the potential of ICT to raise standards in the learning and teaching of science within the overall context of Environmental Studies 5-14. A second area of interest is in the potential of electronic communication to improve primary-secondary liaison. At present, the SOLSN team and Steering Group are looking at the use of web browser technologies to access relatively complex, cross referenced, collections of resources for the purposes of supporting and improving the planning of learning and teaching science at 5-14. Because of technical and operational difficulties (trustfully temporary) in accessing SOLSN on-line, the resource collections are being trialled

in CD ROM format for use off-line. The redesigned site pivots about a curricular planning tool from Renfrewshire derived from the science elements of the 5-14 Guidelines. Should the evaluation results for the pilot be positive, then other parts of the site will be re-introduced. These shall be the bits which were valued by teachers at the feasibility stages (ie the *Cafe* with its on-line *Helpers*, and the *Prep Room* with examples of schools' and pupils' work). At that stage it is hoped that other partners will join (in some cases rejoin) the project, notably ASE Scotland and Initial Teacher Training lecturers and some of their students.

SETPOINT

Single access to comprehensive information about science, engineering, technology and mathematics

SETNET Scotland

Some readers may be familiar with one or other of the twenty-eight or so *SetPoints* around the UK. They make up *SetNet* (Science, Engineering, Technology and Mathematics Network). Until recently there was only one such local network north of the border. This is *SetPoint North Scotland* in Aberdeen which is associated with the North of Scotland SATRO. Now there another two Scottish sites - *SetPoints West* and *East Scotland*.

SetPoint West is based in the Glasgow Education Business Partnership premises and is a collaborative venture. In addition to the local EBP, amongst *SetPoint West's* other partners are: Scottish Engineering; the West of Scotland SATRO; and Glasgow University Science and Technology Outreach (GUSTO) team. *SetPoint East* is based in the Lothian Education Business Partnership and was set up with the support and encouragement of the Royal Society of Edinburgh, the Science and Technology Adviser for the City of Edinburgh Council and SSERC.

Even before formal approval for the East of Scotland *SetPoint*, the three Scottish *SetPoints* had already met to discuss closer collaboration on a Scotland wide basis. That meeting also had representation from *ASE Scotland* (which now also has its own excellent web site - see below). It is possible that *SetNet Scotland* may end up with a single entry point, or gateway out, from the Scottish Virtual Teachers' Centre. It would then come closer to meeting one of the UK *SetNet's* declared objectives - that of providing a one-stop shop for information, advice and other support for science, engineering and technology education.



Welcome to ASE Scotland

Association for Science Education
Scotland

Interactive training materials

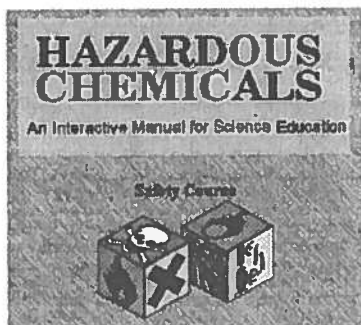

Health and safety training

Many readers will know that we have published a CDROM version of our paper-based publication entitled: *Hazardous Chemicals - A manual for Science Education*. Quite a few now actually have a copy or have access to it on a local authority server. This electronic version covers over 260 chemicals or groups of chemicals and has more than 15,000 cross referencing links.

Fewer will know of the trialled, interactive training material which SSERC has based upon the HazMan CD. Earlier paper based training materials (for SSERC COSHH courses and other purposes) have been converted into HTML¹ format. Thus quizzes, other sets of questions, and various workshop exercises have all been linked into the hazardous chemicals manual. In order to answer questions and solve problems participants surf the body of the manual, its introductory sections or the varied explanatory material in the appendices and glossaries.

Similarly, background material from bulletin articles has also been integrated with sections of the course and linked in with the manual. The electronic HazMan in this mode therefore acts as a large, yet highly accessible, *expert system*. This training model has the added benefit of providing practice in using a web browser but in an obviously useful and practical context. The concept is obviously transferable to other training both within and outwith the context of health and safety.

¹ HTML - *Hypertext Mark-up Language* the basis of the Internet and Web.

We have used the same techniques for training courses in ICT in the Sciences (see below) and on the CD we are currently evaluating as part of the SOLSN project.

ICT in science course

Ian Birrell, SSERC's Network Designer, has also produced an interactive training course on ICT in the sciences. This has been trialled in Fife and is to be run again both there and for other Scottish EAs. This one-day course looks at the uses of ICT in handling words, pictures, number and effects such as animation and sound to enhance and enliven learning and teaching in science. The menu page used for the course CD is shown at the top of the opening page of this article.

SSERCNet

In an attempt to improve our own productivity (and we're still holding our collective breath) Centre staff have been developing our own intranet for internal communication and management purposes. This is still under development but already we can see that it has considerable potential, and not only for our own use. At some point we intend going public with parts of it and opening it up to teachers, technicians and officers in client authorities or subscribing schools and colleges. (The top two thirds or so of our internal home page are shown at the foot of this one).

Generic material

Parts of the SSERC intranet are dedicated to generally useful ICT material. For example there is a collection of useful Search Engine logos. Clicking on a logo takes us straight to that search engine site. There is also useful background information on each search engine and where relevant, its particular strengths or weaknesses. We are also slowly compiling interactive or 'browseable' versions of back issues of our serial publications and of the address lists therein.

cont./over

<p>HAZARDOUS CHEMICALS An Interactive Manual for Science Education</p> <p>Safety Course</p> <p>Lots of Science Sites The Cyclic's Definitions</p>	<p>SOLS Net</p> <p>SOLS Net Disc Guide</p>	<p>Higher Still Arrangements Documents:</p> <p>Chemistry - Physics - Biology Technological Studies - Graphic Communication</p> <p>NEW WMF Graphics</p> <p>NEW Excel Spreadsheets</p> <ul style="list-style-type: none">• Hazardous Chemicals• HazChem Uses & Control Measures• SSERC Chemical Stock 99• Chemical Stock Control (blank)• Standard/Higher Grade Chemicals List• SG/HG Chemistry Equipment List• CHIP List sorted by Name• Bulletins sorted by Articles	<p>Search Engines</p> <p>Schools</p> <p>Web Sites & Email</p> <p>Assorted Links</p>
---	--	---	---

Curricular and management materials

We've also mounted the Higher Still Arrangements Documents on our internal network. Some staff are now busy setting up databases and spreadsheets based on analysing equipment and other resource needs against the Higher Still arrangements and related support materials (see graphic at the foot of this and a list of spreadsheets to the left of the graphic at the bottom of page 7).

We are fairly confident that these spreadsheets will be useful in departmental management and development planning. They also provide an objective and rational basis from which to argue cases for adequate funding. Since the strongest and most successful of such cases seem to be those drawn up co-operatively by the whole science department, then eventually all the science subject spreadsheets will be made available as one linked set of spreadsheets (or - in Microsoft Excel - as an integrated *workbook*). Not to neglect Apple users we are looking to produce compatible versions for that platform or for potential partners to translate our Excel versions into Claris Works.

Miscellaneous

Also on the site are: a collection of useful links to external third party sites; address details for Scottish schools; our stock control systems and a searchable, cumulative list of Bulletin articles. One interesting and useful application of web technique was suggested by

Fife technicians who have already set it up on their EA's intranet. This was to link any chemical in their stock lists or inventory into the relevant entries of the SSERC electronic HazChem manual. The latter is already licensed to Fife and is mounted on its intranet server. As a result, clicking on a hot-linked chemical in the school's inventory takes a technician straight to the relevant entry in the SSERC manual. Once there they can check storage advice, hazard data, uses and control measures or how to handle spillage etc.

Further development

We are wary of saying too much here. This is not because we're afraid others might steal a march. In this sphere we have definitely signed up to the "here, you have this bit" school of collaboration. If a teacher or technician is willing to shoulder some of this sort of development work - on yer go pal! Rather, are we chary of promising much that we shan't be able to deliver. For a national centre, SSERC still only has a relatively small staff team. We have about 8.5 FTE and that includes all of the administrative and technical support staff.

So, please don't badger us but, work is ongoing to convert the Acorn and Apple based SSERC Graphics Libraries to PC format (Windows metafiles). Similarly, although we started with equipment databases for chemistry other subjects will eventually also be covered.

	Name	Supplier	Model/Code	Number per Chemistry Laboratory	Special Chemistry Items per School	Unit Cost £	Cost per Chemistry Lab £	Special Chemistry Items per school £	Cost (£ total £)
21	Desktop PC/Mac with 3.5" floppy drive and CD ROM drive			2		900.00	1800.00	0.00	3600.00
22	Inkjet printer			2		150.00	300.00	0.00	600.00
23	Datalogging software	Griffin	Insight 2 CRD-141-010C		1	79.00	0.00	79.00	79.00
24	Datalogging software 5 user extension	Griffin	Insight 2 CRD-141-040Q		1	89.00	0.00	89.00	89.00
25	Interface	Philip Harris	Chemistry Curriculum Pack(DL plus 128 datalogger, temperature, conductivity, & pH SensorMeters & probes Datadisc PRO, leads, power adaptors, junction box and 15	2		990.00	1980.00	0.00	3960.00
26	Light Level Sensor	Philip Harris	Light SensorMeter E30280/1	2		110.00	220.00	0.00	440.00
27	Position sensor	Philip Harris	Position SensorMeter E30420/2	2		110.00	220.00	0.00	440.00
28	Colorimeter	Philip Harris	S-Range R61010/9		1	378.38	0.00	378.38	378.38
29	Balance and serial adaptor				1	1300.00	0.00	1300.00	1300.00
30	Balance software	Philip Harris	Datamass Pro E50950/9		1	125.00	0.00	125.00	125.00

ICT in Science Education

An article developed from a paper originally drawn up by a working party of the Scottish Science Advisory Group (SSAG).

The Scottish Science Advisory Group has a membership drawn from most of the thirty two Scottish unitary authorities; SCCC, SSERC and HMI. This article is based on a policy paper drawn up by a working group of SSAG. At its most recent meeting in March, SSAG approved an amended version of the ICT sub-group's report and agreed that it be circulated to Education Directors. It was also agreed that SSERC be requested to publish it in an amended form for the direct benefit of teachers, technicians and management personnel in schools. That we are very pleased to do, since it also sets our own efforts against a wider educational and operational backdrop.

Section 1: Background and Rationale

Science and technology education have a key role to play in accessing Information and Communications Technology (ICT) resources so as to grasp opportunities to update, and improve learning and teaching within the curriculum from 5 to 18. As a consequence, a number of needs, and points for action which flow from these, have been identified and categorised. There is a clear need to:

- 1.1. *Further raise awareness and aspirations linked to ICT so as to avoid acceptance by too many science and technology departments of yet more hand-me downs from computing and business studies. We might expect - very probably need - practical empiricists, like science and technology teachers, in the vanguard of current ICT provision not trailing behind merely picking up the crumbs.*
- 1.2. *Begin to update computers and software to improve capabilities for manipulating, analysing and displaying data.*
- 1.3. *Provide more access to advanced communications facilities. This is for a host of reasons, including better sourcing and co-ordinating of educational activities both in and outwith the formal school and college environment.*
- 1.4. *Meet requirements of data logging and interfacing for investigative practical work and control. This provides an imperative to update some more conventional apparatus, so as to enable and expedite such work. There is an associated need for more systems, each with a much smaller footprint, for pupil or student based practical activities.*
- 1.5. *Recognise in practical ways the criticality of training, the lack of which has seen major failures and inefficiency in some past provision, leading to equipment gathering dust or even lying unused in its original boxes.*

2. Hardware Requirements

- 2.1 *Each teaching room should have a minimum of one PC system with CD Drive; Zip Drive; Modem; Internet or Intranet Link; IR Port and Printer.*

The specifications for the chip speed and memory requirements are constantly improving, hence it is more appropriate not to specify minimum values at this time.

- 2.2 *There should be linkage between the PC systems of labs and with a central server to allow appropriate exchange of data both within the department and across the school.*
- 2.3 *Each classroom should have available to it a set of six palmtop or laptop PC computers capable of accepting sensor inputs, and of some initial processing of data, as well as connecting remotely to the main lab PC system to allow more complex data analysis.*

For example, a recent development of NTS laptop computer systems (targeted at the education market and available in charging racks of six) may provide a useful start in this area. The IR ports of such computers can use an overhead link to connect to a desktop PC for both transmission of data and Internet connection.

3. Curricular requirements

General issues: The application of ICT to the science or technology curricula will not change the fundamental scientific ideas nor the technological principles which are taught. However the use of ICT may well provide educational experiences not otherwise available. Such opportunities must inform decisions about what should be included in the curriculum. These decisions, in turn, are always to be based on human understanding of the science itself, the ways by which society benefits from science and in which learning science takes place.

One use of ICT within the science or technology curriculum is directly in its delivery. Specifically, learners and teachers should apply the technology to communicate scientific information. In such a context, the term *communication* means a two-way flow of information; either between users or a similar flow between a user and the environment. The term *information* refers in this context to scientific knowledge and methodology as well as to environmental data measured by sensors or control data transmitted to influence or control environments. Such activities capture the core of science and technology. Both are collaborative and often international in scope. Both are to do with understanding or influencing our natural or built environments.

(cont./)

Specific issues

3.1 Interfacing and datalogging

- 3.1.1 Interfacing is a core application of ICT. It is somewhat peculiar to science and technology and has become the standard term describing the use of a computer, or other microprocessor based device, to make measurements of physical quantities or to control devices. Much scientific study involves the collection of data sets from measurements. The subsequent analysis and interpretation of that data encourages students to draw conclusions and so develop their understanding of scientific principles. Although this process pre-existed recent developments in ICT, and will continue regardless of such developments, the nature of the measurements which can be taken has been changed profoundly. Events which last fractions of a second are no longer impossible to analyse or study. Events which stretch over days or weeks are no longer intolerable to observe in detail.*
- 3.1.2 The application of ICT through interfacing has the potential to extend experiential boundaries for learners. Whereas previously, teachers might describe an investigative process and its results through talk and perhaps by video, learners can now perform that same experiment and analyse the results for themselves. This may accelerate the process by which contemporary contexts and applications come to illustrate fundamental scientific or technological principles. Latterly, curricular inertia has put a drag on this updating process.*
- 3.1.3 Investigative approaches can allow learners to confront new knowledge from personal experience and which challenges their previously held ideas or understanding. This is recognised as a powerful learning process. The use of ICT in such approaches may well mean that students learn more and learn better.*
- 3.1.4 Interfacing has not only allowed new experiments and extended learners' experiences to events outwith direct human perception. In appropriate circumstances it may even change how learners approach more conventional ideas and events. For example, in physics, the teaching of motion has been radically changed through the use of computers interfaced to motion sensors improving the clarity for the learner of the underlying physical principles. The ability to use ICT to measure and control quantities such as temperature, pH and other ion concentrations in biology and chemistry, has made it possible for learners to alter parameters and then immediately to study the effects. This is two way communication with the environment. Such experiences can offer real science and real learning.*

3.2 Datahandling

Science and technology are part only of one of several major curricular components. They by no means offer unique opportunities for handling and analysing data. Nonetheless, this is a particularly rich curricular seam and deserves to be resourced accordingly.

(cont/next col.)

- 3.2.1 Organising and interpreting data are amongst the first applications of ICT to science met by learners. They then continue into later school years, and on into further and higher education and life in general. In primary and early secondary, the science curriculum is described in the 5-14 Guidelines and the subsequent SCCC Content Exemplification: Teachers Guides. These documents highlight where and how ICT is best applied.*
- 3.2.2 Spreadsheets allow children to key-in, or load, data from direct measurements or other sources and also to enter suggested formulae. As the data is entered, the results of the formulae show immediately. This allows for rapid comparison of the data with possible relationships. It can lead children into making decisions about patterns, drawing conclusions and making generalisations. This type of high-level experience is only possible because the spreadsheet performs the low level number crunching. Learners may process data and then compare trends using a variety of graphs and charts. Empirical approaches to such processes can be used to allow development of a feel for data types. Eventually this can develop the learner's ability to accurately predict likely numerical relationships in given data sets.*
- 3.2.3 Databases enable children to organise gathered data into structured formats. Such skills are of widespread scientific and technological application. They are particularly important - for example in subjects like biology, or engineering - where study requires development of thought processes capable of simultaneous juggling of hierarchical structures with multiple sets of variables. Databases can help by mirroring such structures. They are also of direct application to scientific and technological studies of the environment.*
- 3.2.4 Throughout their studies, children are given targets where they need to organise their gathered data using databases, even to the point of building up their own databases with user-defined fields and records. Further use is made of databases when students at any level need to obtain information by searching other databases. This involves some sophisticated information handling skills such as selecting the appropriate, and discarding inappropriate, information. This skill is particularly necessary when searching for information from databases within the Internet.*
- 3.2.5 Once data has been organised and analysed using spreadsheets and/or databases, learners can more effectively record and present their findings using word processors or DTP software. Practising science requires learners to communicate findings after the data capture and analysis phases. This can provide further insight into any acquired knowledge or skills. It reinforces learning. The use of suitable software allows the generation of reports with the ability to draft and redraft as necessary. Learners can produce reports incorporating textual and graphic elements. This can lead to greater satisfaction, increased clarity or sophistication and a greater sense of achievement.*

3.3 Learning and Teaching

3.3.1 *Learning in science can be enabled and enriched through experimental, investigative, activities. Applications of ICT to this area through interfacing and datalogging have been discussed. Learners' experiences may also be enriched through the usage of a much wider range of ICT applications. Appropriate software, using graphics and animation, allows effective modelling of structures and processes. Such modelling has, hitherto, been unsatisfactory, very difficult or even impracticable by other means. Models and displays using colour, movement, pictures, music, text, audio and user interaction may allow access to complex ideas and concepts in ways which suit a wide variety of preferred learning modes. They can access a variety of routes for learning : auditory, visual and spatial and kinaesthetic. At their best, such multimedia packages allow maximum linkage with the brain's multiple intelligences¹.*

3.3.2 *Some kinds of scientific or technological knowledge may only be effectively conveyed through models, graphical representations or animation. For example:*

- *in biology and chemistry the structure of DNA,*
- *in chemistry the structure and vibrational modes of a molecule and*
- *in physics the macroscopic effects due to the motion of large numbers of molecules.*

Graphics databases (eg Chimè and RASMOL for molecular models and animations) can be used both for direct learning and for presentational purposes. Such databases can be accessed also to view photographs or diagrams, video and, or, animation sequences. Through the use of suitable digital image capture equipment, learners can obtain, manipulate and edit graphics and other visual materials.

3.3.3 *When such potentially rich learning experiences are directed and co-ordinated by an effective and competent teacher, they become even more powerful. Further, the use of ICT by some particularly talented teachers can ease the development of quality learning and teaching materials. These in turn may address more appropriately the specific needs of individual learner and make the whole process more interesting and appealing. Teachers' competent and effective use of databases, spreadsheets and DTP for administration offers the prospect of more time for, and emphasis on, the learning and teaching process.*

3.4 Communication

3.4.1 *Communication is at the heart of good teaching. Thus improvements in communication should lead to improvements in learning. Through communication, knowledge is shared, questions asked and answers given. Where there is true dialogue, learning is maximised. In dialogue the learner best exerts influence over the flow of information. This has always been the case. Now, with electronic communications, that circle of sharing has expanded beyond anything imaginable a few years ago.*

3.4.2 *Electronic mail and video conferencing allow the learner to enter dialogue not only with their peers but with additional teachers in other parts of the world. There are sites on the Internet offering both the very latest scientific information and new insights into more established bodies of knowledge. This ability, appropriately managed by the teacher, expands the laboratory and classroom to a limitless learning environment reaching to every corner of the planet.*

3.4.3 *Already established, throughout Scotland, are a number of Higher Education/Further Education learning and teaching networks. Schools could benefit considerably if their Education Authority became an active partner in such networks. Schools would be able to access dedicated teaching materials for a variety of subjects to complement existing programmes (particularly for Advanced Higher).*

4. The Future

Currently ICT is used in many science and technology departments and, as a result, learners have probably benefitted. It must be stressed that high quality learning and teaching still may, and does, take place in departments with little or no up to date ICT activity. Nevertheless, this situation cannot continue. In the next decade and further on into the new century, it will not be possible to address learning needs nor deliver effectively the types of knowledge or skills required of future scientists without the use of ICT. The use of ICT in the science or technology curriculum, is moving rapidly from desirable to the essential. It is becoming critical that equipment provision and training issues be addressed, and that as soon as possible, to ensure the necessary state of readiness and capability in our schools and colleges.

5. Training issues

5.1. What kinds of training?

5.1.1 *Initially there is a need to inform all science staff of the potential educational benefits to be gained through the use of the technologies. They also need to know about the pitfalls and traps for the unwary. Through the development planning process, departments should be encouraged to develop an overall ICT policy and action plan.*

5.1.2 *Training is needed on data capture and data manipulation. This should incorporate advice and training with new hardware and software for PCs or Apple Macintosh. Some of the more novel applications such as video capture and digital image manipulation will have to be included.*

5.1.3 *Training is required for both generic (content-free) and application specific, software packages to allow students to become involved with processing data and then presenting their findings. Such packages include the use of spreadsheets, databases and word processing. There will also need to be advice and support on the integration of this data manipulation and presentation with ongoing coursework. This will inevitably be linked to issues associated with appropriate hardware.*

1. As defined by Howard Gardner.

5.1.4 *Many more learning and teaching, assessment and support materials are becoming available in CDROM format. Unfortunately, the materials all too frequently are not linked specifically to the Scottish curriculum. Exemplification of how to integrate such material into classwork is required. This is also a need to consider some electronic means of sharing ideas or news of good resources that could be used in specific courses.*

5.1.5 *Similar issues to those identified in 5.1.4 are to be found in considering uses of the Internet. Teachers and technicians need to be trained first of all in how to navigate the Web. It is then vital to train them in how to cope with the amount of information which is available.*

5.1.6 *Strategies for integrating Internet information into classroom practice have to continue to be developed and then disseminated. Some specific advice in the identification of useful URLs¹ for teaching science should be given. This information will date quickly and so a strategy will be needed for updating on a regular basis.*

5.1.7 *Training will also be required for the effective use of E-mail.*

5.1.8 *The outcomes from the SOLSN study and its expansion should be beneficial in informing the detailed provisions of much of this training.*

5.2 How can such training be provided?

5.2.1 *There is no one method, nor single agency, capable of meeting all training needs. Both scope and depth of the training required will necessitate a variety of approaches.*

5.2.2 *Local Authorities should be key players in this training. Each will have a variety of departments or agencies which could deliver generic training on use of software packages, on accessing both the Internet and any local Intranet as well as in using e-mail. The National scheme for training in ICT will provide the backdrop for much of this activity.*

5.2.3 *Authorities may need to enlist the help of appropriate outside agencies for specific training associated with science education such as data capture, data processing, relevant control technologies etc.*

5.2.4 *Science teachers could attend school based courses of cross curricular relevance. These might well be delivered by business studies or computing departments. Following such training, subject departments could develop the curricular links for science and technology. Teachers with well developed ICT skills should be both encouraged and enabled to share their expertise and train their colleagues.*

5.2.5 *So called cascading is largely discredited and should be strictly limited to one phase. That is, a teacher may be trained as a trainer and then be resourced to themselves directly train colleagues. Colleagues so trained should not however be expected, in any formal sense, in turn to train others.*

5.2.6 *Science teachers may choose to enhance their own skills on a self-taught basis, using either a home computer or a school machine. As well as providing opportunities to acquire and consolidate new skills, this also allows staff to assess their personal needs for more formal training.*

5.2.7 *It is well known that should new skills not be used, then they are soon forgotten. Following a course it may be necessary to give some form of back-up training and support. This may be provided by the school, the Local Authority or an outside agency. It may take the form of back-up visit(s) or a helpline.*

5.3 Where do we go from here?

The following suggestions are offered as contributions to the debate on appropriate short and medium term strategies on the use of ICT in science teaching. Some have relevance also to technological education. All are suggested as practical action points.

1. In consultation with, and the assistance of, teachers and technical support staff - establish clear, pragmatic and practicable guidelines for the effective use of ICT in the learning and teaching of Science.
2. Keep such guidelines under review and amend them in the light of developing practice. Actively involve practitioners in the review process.
3. Encourage the incorporation of such guidelines into whole-school ICT policies.
4. Publicise good practice to stimulate interest in the effective use of new technology for learning and teaching.
5. Encourage and support emerging Scottish science, engineering and technology networks (eg Scottish SetNet, SSERCNet, ASE Scotland's Website (and eventually those networks which may be based on Science Centres and promoted through the Scottish Science Trust) .
6. Actively support teachers in accessing such networks for the provision of advice and support.
7. Develop a properly integrated Scottish Science and Technology Training Programme for ICT.

Footnote : ¹ URL - Uniform Resource Locator

Membership of the ICT Task Group : Peter Anderson, Fife (Chair); Ian Birrell, SSERC; Bill Fleming, Renfrewshire (Secretary); David Lawson, Glasgow City.

TECHNICAL TIPS

Simple science surfer's guide

One of several useful handouts picked up at the ASE Conference "ICT and Science Education" (which preceded the 1999 UK Annual Meeting) was a single piece of A4 entitled : *Topical Tips - Using the Internet*¹. We have adapted this for our own use here in the Centre. We judge that some of our readers may also find it a useful beginner's guide. Here, therefore for what it's worth, it is. (All of this and more will be accessible on SSERCNet or SETNet Scotland - soon!?).

1. When browsing, turn images off. This will download text data much more quickly. You can turn the images back on when you find what looks like a useful page.
2. Save a *bookmark* in the browser's Bookmark or Favourites list for sites found to be particularly useful; this will save on-line time in future and avoid the frustration of not being able to find a site again at a later date!
3. Keep an up to date address book of Email contacts to speed message composition; not all e-mail addresses are available using Internet Email search tools.
4. Use Email and Email lists to ask advice from colleagues and consider joining Email discussion or information lists such as those run by ASE (SciEdnet) or NCBE.
5. Save or convert documents to be sent as Email attachments to rich text format (rtf) to ensure the recipient's software will be able to open the file. This should also make it more difficult for nasty nerds or horrid hackers to attach viruses and so *infect* your mail.
6. Save or convert image (graphics) files to be sent as attachments to jpg or gif format. This reduces the file size, allows quicker transport over the Internet and is less likely to clog up hard disks at the other end.
7. Save a copy of frequently accessed pages, individual images, or the text to your computer for use locally. If you cannot download the image(s) on a page try clicking with the right hand button of your mouse.
8. Consider using proprietary software (for example - *WebWhacker* or *Teleport-Pro*) to download entire sites where appropriate, eg where access on-line cannot be guaranteed or is unreliable (and copyright is not an issue). This is called cacheing (no accent and thus not to be confused . . .)
9. Where you do download websites, make sure that you revisit them, and update your versions, regularly or the resource will become static and progressively less useful.
10. Work off-line whenever possible to reduce costs and Internet traffic. Go on-line only when really necessary.
11. Where possible, surf and download pages during the morning (in the UK) when Internet traffic is reportedly lighter, to decrease time on-line.
12. To locate resources produced in the UK more rapidly, use UK specific search engines eg *Mirago* (<http://www.mirago.co.uk>)



13. Use multiple search engines eg. *Dogpile* or *Copernic* (<http://www.copernic.com/>)
14. When checking search results on a PC, use right click on the mouse to open a new browser window. This retains the search results page and saves time in using the *back* button.
15. Buy a copy of the *Rough Guide to the Internet*. (Even if you never use it, think what it will do for your combined Street and Tech Cred).
16. Time spent familiarising yourself with your chosen Internet software package - Email, news, web-browser - will be well spent. Don't keep swapping applications just so as to get the latest gizmos.
17. Try out some of the on-line learning sites (eg <http://www.zdu.com.>). If you have on-line access then the best of these sites provide cheap ways to increase your skill levels.
18. Locate or, on the recommendation of professional peers, collect some good web sites from reputable sources. Get used to applying these in your own work to their maximum effect. It is otherwise all too easy to waste time trying to use lots of dubious sites less efficiently and effectively. You could do a lot worse than make the ASE your first port of call (see <http://www.ase.org.uk>) and they will lead you to some super stuff from practitioners and on to good third party sites. Better still - join.
19. Get yourself and your pupils engaged in on-line projects. You'll increase competence and confidence with ICT and hardly feel the pain. This can also greatly increase pupil motivation. Check out the *European Schoolnet* pages for useful information (<http://www.eun.org>). ASE is involved also in a *Science across the World* initiative.
20. Visit, or encourage pupils to visit, science websites in other languages. For example, no biologist looking to brush up their French and get some super ideas for exciting practical work, should be without the URL of Prof. Didier le Pol (<http://www.users.imagnet.fr~pol/>)
21. Set up and develop a school Intranet. You can use this to develop expertise in Internet technologies, to produce in-house, on-line, materials and to work collaboratively in multi-disciplinary teams. With an intranet you can use web techniques but avoid on-line costs or significant risk of exposure to *bad* content or dodgy *Cagouards*².

That makes twenty one tips.
Three times seven = magic! Not that I believe any of that superstitious stuff. But then, most of us Gemini are like that - cynical twosomes.



¹ Issued jointly by *Educating for an Open Society* and the *Cyberskills Movement*. ² Wilson Flood's alternate term for 'Anoraks'. Between the wars *Les Cagouards* (literally - the 'hooded ones') were a shadowy, extremist, french political group.

EQUIPMENT NOTES

Projectile Launcher

Physics is fun! Or it certainly should be with apparatus like this. Once you have aimed, it can reliably lob projectiles into a coffee cup at five metres.

"Nobody can be uncheered with a balloon". You could substitute a projectile launcher for the balloon and few would disagree. In fact our test report need say no more than this suggested alteration to Eeyore's comment on a balloon - *nobody can be uncheered with a projectile launcher* - and that sums it up!

But we would be in delict of our duty as apparatus eviscerators by not giving you a scientific account of the performance of this PASCO apparatus (ME6800). On what criteria do you decide whether it is any good? If it's fun, do we really need to look any further?

Let me explain to you how I decide on what criteria to set. I'll tell you a wee story. I was in a school last week testing another piece of apparatus - the PASCO *Kinesthetics Cart Number 1*, which is basically a bogie or cart on which a pupil sits to experience effects of Newton's Laws of Motion. I was working with a teacher and about half a dozen CSYS Physics students. We had been using the Cart for about an hour when I brought out the Projectile Launcher - apparatus which was new to everyone else present. It was initially mounted on a benchtop and fired. They saw that a ball projected at an elevation of 90° returned to strike the bench close to where the Launcher was sitting.

The Launcher was then mounted on the Cart, being secured with a large G clamp. (I had never seen it used on a Cart before.) The students were asked to predict what would happen. Clearly understanding the physics behind this question, they began to discuss the effects of friction. The opening statement was, "Air resistance will cause the ball to fall behind the Cart". "But the Cart will also be affected by friction", another pointed out.

Wanting to keep the discussion simple, I said, "Forget second order effects and concentrate on the primary ones. What do you expect will happen?"

"The Cart will travel at constant velocity. The projectile will have a horizontal velocity component of the same value and will keep up with the Cart. Therefore it will hit the Launcher", it was asserted.

We ran the experiment three times (Fig. 1). On the first try, the ball hit the Cart alongside the Launcher. On the second, it hit the muzzle. And on the third, it hit the base supporting the muzzle. We were able to see that the second order effects of drag and friction are trivial compared with the primary effect - that in the absence of a horizontal force, the two bodies travel with constant velocity in the horizontal sense.

From this wee story you should be able to tease out what to expect of well designed, educational apparatus. Firstly you should be able to repeat the action and get consistently similar effects. Secondly, the performance should manifest the primary physical effects you are trying to show and these should not be obscured by second order complications, such as friction in this instance.

The Launcher (and Cart) patently meet these criteria in so far as this demonstration is concerned.

Description

- The Projectile Launcher (Fig. 2) fires 25 mm diameter balls. There are two types of ball. The standard one is solid nylon, in fluorescent yellow, weighing 10 g. The other is a steel ball bearing and weighs 66 g.
- Balls can be launched at any upward angle from 0° to 90° from the horizontal.
- The angle of elevation of the barrel is shown by a plumb line hanging against a protractor scale marked in divisions of one degree. The resolution is $\frac{1}{2}^\circ$.

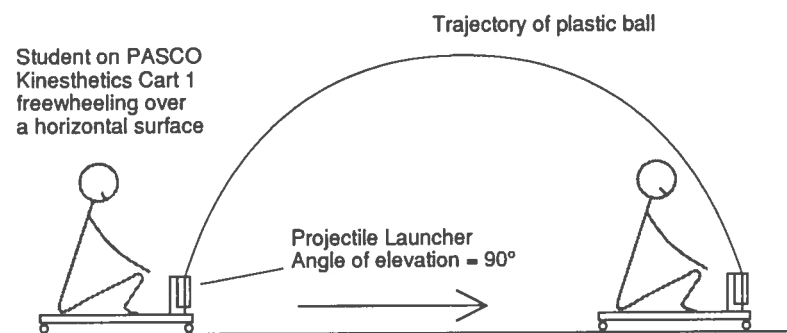

Figure 1 Projectile Launcher on Kinesthetics Cart demonstrating independence of motion of projectile.

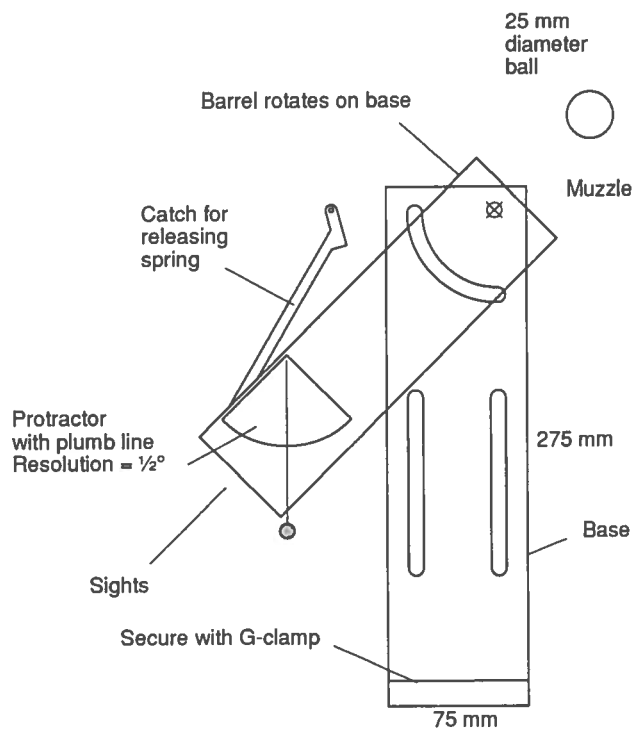

Figure 2 Projectile Launcher (side elevation).

- The barrel swivels on a base which is quite massive, being composed of 12 mm thick aluminium. The barrel elevation is set by tightening thumbscrews.
- The base should be clamped to a sturdy benchtop. If it is not so clamped, then the barrel may shake during firing. This impairs the repeatability of results and shows up as a sizeable scatter in the range and direction.
- The system is energized by compressing a spring. A ball is placed in the muzzle and pushed down the barrel with a ramrod. There are three spring settings, giving the plastic ball ranges of 1.2 m, 3 m and 5 m when the elevation is 45°.
- The barrel has viewing slots through which you can see the position of an energized ball and to what range it has been set. Students should be instructed to use the viewing slots and not look directly down the barrel to see where the ball is.
- The spring is cocked by a catch on a long lever. It reliably prevents accidental release, but yields to a slight tug on a lanyard causing minimal disturbance to the Launcher.
- The ball sits on a vibration damping ring mounted on the piston at the end of the spring. Because of the damping ring, for all angles of elevation, the ball does not touch the inner barrel wall during firing, thus preventing spin.
- The pivot about which the barrel rotates coincides with the centre of the ball at its point of projection. This ensures that the ball is fired from the same position in space whatever the launch angle.

- Because the position of launch is about 26 cm above the base, if you want to find the range where the landing site is on the same horizontal plane, you may need to set up a landing pad above the workbench. This can be the *Time-of-Flight Accessory* (see below) mounted on a lab jack.
- Before a ball is inserted into the muzzle, the experimenter can aim the Launcher by aligning a set of sights within the barrel on a target. This lets you carry out a Monkey and Hunter demonstration.

Ancillary equipment used by us in testing the Projectile Launcher included :

- *Accessory Bracket ME-6821* with two *Photogate Heads ME-9498A* connected to a Unilab digital timer to measure the muzzle velocity and, along with the next item, time of flight.
- *Time-of-Flight Accessory ME-6810* : This is a flat pad with a piezoelectric transducer. When the projectile lands on the pad, an electrical signal is sent to the timer to stop the timing.
- *Shoot the Target Accessory ME-6805* : Apparatus for showing the Monkey and Hunter experiment including a magnetic target which clings to a Drop Box which is de-activated with a signal from a photogate mounted by the muzzle.

Performance tests

The PASCO Projectile Launcher was assessed by comparing its performance with theoretical models. The factors considered are range, time of flight and muzzle velocity.

Theoretical model

This model considers an ideal system. It ignores friction.

The horizontal and vertical displacements are given by,

$$x(t) = v_m \cdot \cos \theta \cdot t$$

$$\text{and } y(t) = v_m \cdot \sin \theta \cdot t - \frac{1}{2}gt^2$$

respectively, where θ is the angle of elevation and v_m is the muzzle velocity (i.e. the instantaneous velocity at $t = 0$) (Fig. 3). Differentiating with respect to time this gives the instantaneous velocity components as,

$$v_x = v_m \cdot \cos \theta \quad (\text{time independent})$$

$$\text{and } v_y = v_m \cdot \sin \theta - gt \quad (\text{time variable})$$

When fired at angle θ , the spring and ball experience a retarding gravitational force. The total energy exerted by the spring in pushing the ball over a constant contracted distance d will be the same for all angles (Fig. 4). At $\theta = 0^\circ$, the gravitational retardation will be zero - spring potential will convert entirely into kinetic energy. At $\theta = 90^\circ$ it will be a maximum - spring potential will convert into kinetic and gravitational energy.

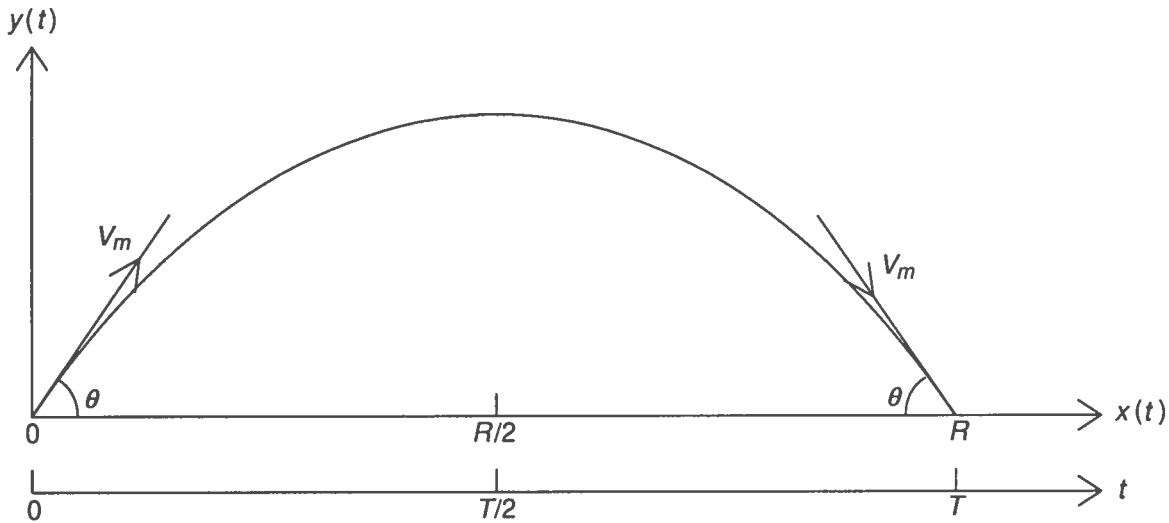

Figure 3 Variables related to projectile's trajectory.

By energy conservation,

$$\frac{1}{2} m v_o^2 = \frac{1}{2} m v_m^2 + mgh$$

$$\Rightarrow v_m = (v_o^2 - 2gd \sin \theta)^{1/2}$$

where v_o is muzzle velocity at $\theta = 0^\circ$ and $h = d \sin \theta$.

The time of flight is T . At $t = T/2$, the ball is at maximum height and vertical velocity is zero,

$$\text{i.e. } y'(T/2) = v_m \sin \theta - g(T/2) = 0$$

$$\Rightarrow T = (2/g) v_m \sin \theta$$

The range is R . At $t = T$, $x(T) = R$,

$$\text{i.e. } x(T) = v_m \cos \theta T = R$$

$$\Rightarrow R = v_m^2 2 \sin \theta \cos \theta \cdot (1/g)$$

$$\Rightarrow R = (1/g) v_m^2 \sin (2\theta)$$

Time of flight T and range R are defined (for a trajectory where the landing spot is on the horizontal plane of the muzzle) in Figure 3.

In summary, expressions for muzzle velocity, time of flight and range where the muzzle and landing site are in the same horizontal plane have been derived as follows,

$$v_m = (v_o^2 - 2gd \sin \theta)^{1/2} \quad 1$$

$$T = (2/g) v_m \sin \theta \quad 2$$

$$R = (1/g) v_m^2 \sin (2\theta) \quad 3$$

A value for v_o was determined by measurement with a nylon ball. Using this, calculated values for muzzle velocity v_m , flight time T and range R are given in Tables 1 and 2.

Muzzle velocity measurement

To measure muzzle velocity, two PASCO light gates were attached to the launcher with the accessory bracket. The outputs from the gates went to a Unilab digital timer. Twelve measurements of time were taken for each angle of elevation at 15° increments, starting at 0° , finishing at 90° .

Velocity values (Table 1) were derived using the distance between the light gates and the mean of the set of 12 time measurements. The velocity uncertainties are the combination of the random uncertainties in time measurements, light gate parallax, non-linear trajectory and light gate separation measurement. This gives an uncertainty in velocity of 2%, to a 95% confidence limit.

From the comparison of the theoretical and measured muzzle velocity values (Table 1) it is apparent that there is less agreement at lower velocities than at higher velocities. The main reason is that the theoretical value is a value of the velocity at the muzzle, whereas the

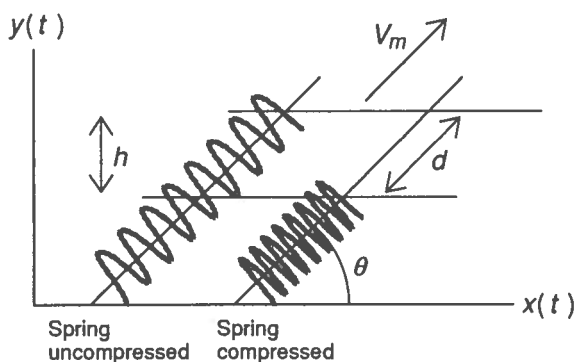

Figure 4 Variables related to compressed spring.

Set range	Elevation						
	0° (m s ⁻¹)	15° (m s ⁻¹)	30° (m s ⁻¹)	45° (m s ⁻¹)	60° (m s ⁻¹)	75° (m s ⁻¹)	90° (m s ⁻¹)
Short (theoretical)	-	3.23 ± 0.07	3.21 ± 0.07	3.19 ± 0.07	3.17 ± 0.07	3.16 ± 0.07	3.16 ± 0.07
(measured)	3.26 ± 0.07	3.14 ± 0.06	3.06 ± 0.06	2.96 ± 0.06	2.91 ± 0.06	2.86 ± 0.06	2.83 ± 0.06
AGREEMENT	-	YES	NO	NO	NO	NO	NO
Medium (theoretical)	-	5.08 ± 0.10	5.06 ± 0.10	5.04 ± 0.10	5.02 ± 0.10	5.01 ± 0.10	5.01 ± 0.10
(measured)	5.11 ± 0.10	5.06 ± 0.10	4.97 ± 0.10	4.89 ± 0.10	4.81 ± 0.10	4.76 ± 0.10	4.77 ± 0.10
AGREEMENT	-	YES	YES	YES	NO	NO	NO
Long (theoretical)	-	6.93 ± 0.14	6.91 ± 0.14	6.89 ± 0.14	6.87 ± 0.14	6.86 ± 0.14	6.86 ± 0.14
(measured)	6.96 ± 0.14	6.87 ± 0.13	6.74 ± 0.13	6.71 ± 0.13	6.68 ± 0.13	6.64 ± 0.13	6.62 ± 0.13
AGREEMENT	-	YES	YES	YES	YES	YES	YES

Table 1 Muzzle velocities v_0 and v_m . Comparison of theoretical and measured values for a nylon ball showing where there is agreement.

Measured values are calculated from measurements of the time to pass a pair of photogates mounted at the muzzle. Theoretical values are derived from Equation 1.

measured value is one of the average velocity over the 10 cm gap between light gates in front of the muzzle.

If the ball has a vertical velocity component, then it decelerates between the light gates. The resulting drop in velocity is less significant at higher velocities since the time taken to pass between the gates is less. Thus the differences are greater for short range settings and higher angles of elevation.

There is no simple mathematical expression for finding the velocity at the muzzle from the measured velocity. To obtain measurements closest to the theoretical values, the long range setting should be used.

Range and time of flight measurements

These measurements were carried out simultaneously. The launcher and sensor pad were positioned carefully in such a way that the points of projection and landing were in the same horizontal plane. Although it is simple enough to do this with a good spirit level for the short range projections (where the range is no more than a metre), it is quite tricky for the medium and long range projections.

Our method for obtaining a good horizontal level between the points of projection and landing made use of an air track to get a horizontal, and a laser for extending the level over the total, five metre, firing range.

Flight times were measured using a light gate mounted on the muzzle, the sensor pad and a Unilab digital timer. A scatter of landing points was made by placing on the landing sensor a sheet of white paper and a sheet of carbon paper. On the white paper, a line at a known distance from the projectile launcher was drawn. The distances of each point from that line were measured to calculate the range (Fig. 5).

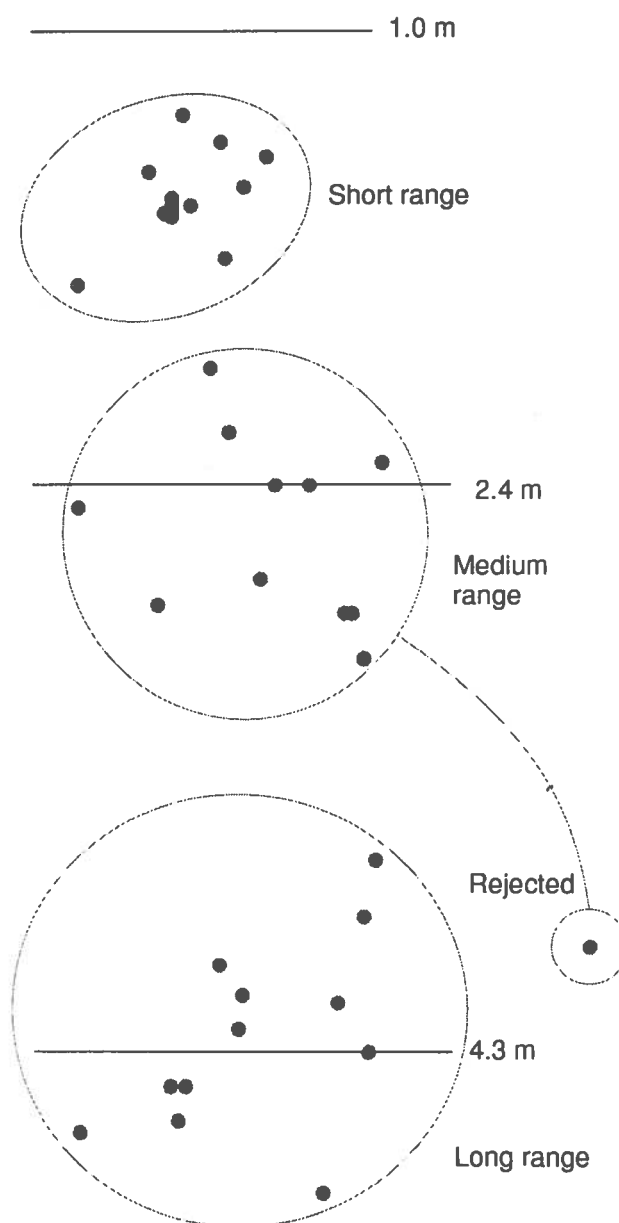

Figure 5 Relative points of impact with a nylon ball (drawn to actual size).

Set range		Flight time (ms)	Range (mm)
Short	(Theoretical)	460 ± 9	1037 ± 21
	(Measured)	435 ± 2	986 ± 16
	<i>DISCREPANCY</i>	5%	5%
Medium	(Theoretical)	729 ± 15	2589 ± 52
	(Measured)	704 ± 2	2389 ± 17
	<i>DISCREPANCY</i>	3%	8%
Long	(Theoretical)	993 ± 20	4839 ± 97
	(Measured)	951 ± 2	4302 ± 18
	<i>DISCREPANCY</i>	4%	11%

Table 2 Comparison of measured and theoretical values of range R and flight time T for projecting a nylon ball at elevations of 45° .

Causes for uncertainties in measured values are listed below, with 95% confidence limits :

Sources contributing to uncertainty in the value of range:

Tape measurement	± 15 mm
Levelling	± 5 mm
Random scatter (Short range)	± 4 mm
(Medium range)	± 7 mm
(Long range)	± 8 mm

Sources contributing to uncertainty in the value of flight time :

Digital timing measurement	± 1 ms
Random uncertainty	± 2 ms

The range uncertainty is largely due to the type of tape measure used - a flexible plastic tape. There were uncertainties due to end point positioning and sag.

The levelling uncertainty was calculated as follows. When the ball is landing, it falls at the same velocity that it is projected at. For a small distance around its landing area, it has almost linear motion. Then a small vertical displacement y corresponds to a small horizontal displacement x where $y = x \tan \theta$. Because the vertical uncertainty in aligning the laser is ± 5 mm, the horizontal uncertainty at $\theta = 45^\circ$ is also ± 5 mm.

Twelve values were taken for each of the range settings at an angle of 45° . This angle was chosen because it would give the projectiles their longest flight path where the effect of drag would be at a maximum. This will indicate the worst case performance due to second order causes. The mean values of the results are shown (Table 2), along with the combined uncertainties with 95% confidence limits.

There was one rogue point in the scatter diagram for the medium setting. The main reason for considering it as a rogue point is that it is significantly separate from the other points (it is at least five standard deviations from the mean). This point is rejected from the analysis.

There is no agreement between any set of theoretical and actual values. The main reason for this will be air friction. Drag factors can be calculated by considering the difference between theoretical and actual values as a percentage of the theoretical value.

Because of drag, the short range is foreshortened by 5%, the long by 11%. The flight times lie between 3% and 5% below the ideal values. There are two points to note.

Firstly, the discrepancies between the values in range rise with greater spring strengths because drag increases with speed.

Secondly, discrepancies in flight times are less than in range. This is due to drag acting in different ways in the two parts of vertical motion (upward and downward). When the ball is travelling upwards, its deceleration will be greater than the ideal model, reducing the maximum height it can reach and also the time it takes to do so. On the downward journey, the ball does not have as great an acceleration as it theoretically should do, so takes a longer time to descend. The effect is that the downward section of motion is slower than the upward. Moreover as its maximum height attained is less than the theoretical model predicts, the total time taken is less also.

Repeatability

Repeatability of results, as claimed, is reasonably true. Out of at least 200 measurements taken, there was only one rogue point. For the short range setting, all the points on the scatter diagram were within a circle of 15 mm radius. For the medium range it was 23 mm (excluding the rogue point), and for the long it was 30 mm. These values indicate that the scattering angle is less than half a degree. The main factor in causing the scatter is vibrations during launch; when the spring fires it causes the apparatus to shake.

Video analysis

The effects of drag on the nylon and steel balls were investigated by filming trajectories with a Connectix *Quickcam* digital camera. The camera was set up 4 m from the firing range. The movies were analysed using *VideoPoint* and *Excel '97*.

We had hoped to be able to plot velocity - time graphs for the two components of motion. By recording at 20 samples a second, flights produced 10 points for analysis. However the uncertainties were very great, and no worthwhile quantitative results were obtained.

From comparing graphs of the horizontal velocity component versus time, we were able to see that the steel ball was decelerating at roughly -0.05 m s^{-2} whereas the nylon ball's deceleration was roughly -0.4 m s^{-2} and increasing with time.

Summary

1. The Projectile apparatus gives repeatable results. The uncertainty in range is only 8 mm at 4 metres.
2. With the nylon ball, actual flight times are about 4% less than theoretical predictions which ignore air resistance.
3. With the nylon ball, the worst case discrepancy for range is 11% between actual values and theoretical predictions that ignore air resistance.
4. Discrepancies with the steel ball are less than with the nylon ball.
5. The ancillary equipment to measure time of flight and perform the Monkey and Hunter experiment operates well.
6. There are other versions of Projectile Launchers and other ancillary equipment available which we have not reviewed (Tables 3 and 4). Please consult PASCO's catalogue for details.
7. Eye protection must be worn when operating the Launcher. Eye protection should conform to the requirements of BS EN 166 for increased robustness and should be marked with symbol *S*. The eye protectors included with the kit are not so marked. They are presumably designed to a US standard and may not conform with UK safety standards.

Acknowledgement

The tests, measurements and analysis were carried out by our student assistant, Stevaan Hall, now on industrial placement at DERA in the Malvern Hills and sadly, from our point of view, no longer working at SSERC.

Type of launcher	Reference	Price (£)	Range (m)	Launch angles	Notes
Tabletop Mini Launcher	ME-6825	124	0.5, 1, 2	0 to +90°, 0 to -45°	
Projectile Launcher (Short Range)	ME-6800	278	1.2, 3, 5	0 to +90°	Reviewed in this article
Projectile Launcher (Long Range)	ME-6801	278	2.5, 5, 8	0 to +90°	
Demo Launcher	ME-6823	362	7.5, 10.75, 12.25, 14	0 to +90°	

Table 3 Summary of PASCO's four projectile launchers. The Short Range Launcher ME-6800 is reviewed in this article.

Launcher accessories	Reference	Price (£)	For use with	Notes
Time of Flight Accessory	ME-6810	58	All Launchers	Receptor pad with piezoelectric sensor signalling timer to stop on impact.
Photogate Head	ME-9498A	41	All Launchers	Light gate that fits on muzzle signalling timer to start timing.
Photogate Mounting Bracket	ME-6821	17	All Launchers	For attaching Photogate to Launcher.
Shoot-the-Target Accessory	ME-6805	217	ME-6800, ME-6801	Monkey and Hunter demonstration (includes ME-9498A and ME-6821).
Shoot the Target II	ME-6826	120	ME-6825	Miniature Monkey and Hunter Apparatus.
Projectile Catcher Accessory	ME-6815	87	ME-6800, ME-6801	For ballistic pendulum, energy and momentum experiments.
Mini Catcher	ME-6814	76	ME-6825	As above.

Table 4 Some of the accessories for the projectile launchers.

EQUIPMENT NOTES

New pupil oscilloscope

We review a "user friendly" dual trace oscilloscope recently designed for schools by Waugh Instruments.

Recent Equipment Notes on oscilloscopes have bewailed the lack of the so-called pupil oscilloscope [1, 2]. Apart from a few single trace machines [2], there had been for many years no dual trace model until this recent development.

Who are Waugh Instruments? They specialise in the repair and calibration of oscilloscopes, design and make a small range of laboratory instruments and have a lot of experience in fixing equipment sent to them by schools. Having found that many of the dual trace oscilloscopes sent for repair were not faulty at all, they came to the conclusion that some teachers and technicians are unsure on how to set up the controls. A common problem has been to find that the CRO had been set for component testing with the timebase disabled. Bearing this in mind they have designed a dual trace oscilloscope with minimalist controls while allowing the user to find and stabilize a trace with ease and measure its time and voltage parameters with accuracy.

We think that they have succeeded. The *DB20* claims to be user friendly. In this we concur. It is much easier to operate than any other 20 MHz oscilloscope we have looked at.

There is scarcely anything omitted from its specification that might be of use in school experiments. So that you may judge this for yourself, look at the right hand column of the table on the opposite page. This lists features which you commonly find on other oscilloscopes, but which have been omitted by Waugh from their machine. How often do you use any of these features?

The *DB20* switches between *alternate* and *chopped* modes automatically when displaying dual traces. This is selected manually on other models, but quite rightly Waugh has left out this option and automated the switch-over. Learning when to apply the best, appropriate mode is an unwanted difficulty with beginners.

There are only four triggering controls on the *DB20* compared with perhaps twelve or more provided on other instruments.

The oscilloscope is always *automatically* triggered, implying that there is always a trace, even in the absence of a signal, provided that the X and Y shifts are not at extreme settings.

The omission of *normal* triggering may prevent the user displaying clearly some complex or peculiar waveforms such as a square wave with a mark to space ratio of 1 to 100. The omission of *alternate mode triggering* would prevent the simultaneous display of two

SPECIFICATIONS

Feature	Waugh DB20 specification
CRT	6 inch screen
Effective area	8 cm x 10 cm
Trace align	Yes
No. of channels	2 (Channels A and B)
Input terminals	BNC, or 4 mm, or one of each
HELP	Returns all traces to the screen
Vertical sensitivity	5 mV/div - 10 V/div
Variable gain	No
x5 Magnification	No
Accuracy	±3%
Input impedance	1 MΩ 30 pF
Freq. bandwidth	DC to 20 MHz
Input coupling	AC, GND, DC
Operating modes	CH A, CH B, Dual trace and X-Y
Polarity changing	No
X-Y operation	CH A : X, CH B : Y
EXT trigger	Yes
Trigger modes	AUTO
Trigger source	CH A, CH B, EXT
Trigger level	Yes
Trigger slope	+/-
Bright line auto	Trace free runs at all sweep speeds in the absence of a trigger signal
Sweep time	0.2 μs/div - 0.1 s/div
Variable sweep	No
Sweep magn.	x5 (increases fastest sweep to 40 ns/cm)
Accuracy	±3%
Callibrator	2 kHz square wave
Dimensions (W x H x D)	312 x 153 x 400 mm
Weight	5 kg
Control recognition	Button caps colour coded

asynchronous waveforms. However generally in secondary education, waveforms under inspection are of a simple kind. These omissions are of little consequence. In fact the misapplication of *alternate mode triggering* fools the user by removing phase differences between synchronous signals. Unless understood and properly applied, it is more of a nuisance than an asset.

The small number of triggering controls which are provided allow the student to learn the essentials of how to trigger on a signal, without being confused by too many control options. Thus the student can learn to distinguish between internal and external triggering, the channel source, and signal slope and level.

Other complications left out by Waugh include trace addition and inversion, and magnification controls, both of the switched and continuous kinds. Generally six magnification switches are provided - two on each of the channel amplifiers, and two controlling the sweep rate. The *DB20* provides one of these, allowing the sweep rate

FEATURES PRESENT	FEATURES ABSENT
Calibrated sweep rate settings 1, 2, 5, 10 switched settings	Alternate and chopped operation
Sweep disable facility	Algebraic addition of traces
Sweep rate magnification (x5) switch	Inversion of one or both traces
Calibrated Y amplifier settings 1, 2, 5, 10 switched settings	Sweep rate variable magnifier or attenuator
X shift	Y amplifier variable gain or attenuator
Y shift	Y amplifier magnification switch
Trace locate function (HELP switch)	Component testing facility
X-Y facility	Illuminated graticule
Brilliance control	Amplifier output
Focus control	Z-modulation facility
Trace rotation adjustment	
2 kHz calibration signal	
TRIGGERING :	
Automatic triggering	Normal triggering
Manual trigger level control	Alternate or vertical mode triggering
Selection of trigger slope polarity (+/-)	Sweep hold-off facility
External triggering	LF triggering, or HF rejection
	HF triggering
	Supply line triggering
	Single shot triggering
	TV sync pulse separator facility

to be speeded up fivefold. It boosts the fastest setting of 200 ns/cm to 40 ns/cm. In our opinion this is unnecessary. It spoils what otherwise would be a minimalist set of controls. But for this switch, all of the settings would be exactly as indicated on the rotary switches.

Waugh provide one switch setting seldom found on other oscilloscopes - namely, a *HELP* button. This restricts the display to the screen area letting you see where the trace has gone so that you can adjust the controls to centre it.

Performance

The instrument has been inspected and tested for electrical safety. It has no significant safety defects.

Performance testing has been done to check for compliance with its technical specification. We found that it complies except for two matters :

- The timebase error exceeded its specified tolerance of 3% in four out of eighteen settings.
- The horizontal deflection is distorted when the x 5 *PULL* is applied.

The first of these faults indicates carelessness in calibrating the instrument after manufacture, a point which Waugh has acknowledged. The problem has been traced to the wrong type of diode in the timebase circuit. We understand that it has been put right. The second fault is unimportant.

The list price of the DB20 is £318, not including VAT. The price to schools is £302 with a 5% educational discount. This is quite a fair and reasonable price. It should be compared with past recommendations [2] : the Crotech 3305 (£265) and ISO-TECH ISR 620 - superseded by ISR 622 (£335).

The instrument case is bright yellow. Weighing only 5 kg, it is lighter to carry than any other comparable oscilloscope.

The purchaser has a choice of input terminals : 4 mm, or BNC, or both of these with one type fitted on Channel A and the other type fitted on Channel B.

Colour coding of the control knob caps should help the teacher instruct a class of students. For instance, referral to the lower red knob uniquely and exactly directs the student to the timebase control, whereas referring to this control by name may not direct the student to the right place.

Assessment

The Waugh DB20 Dual Trace Oscilloscope is awarded an *A* assessment (*A* = most suitable for use in Scottish schools and non-advanced FE).

In summary it has no significant safety defects, performs to specification, and has functional features which make it specially suited for use in education.

References

- 1 *Oscilloscopes* Equipment Notes Bulletin 176 SSERC 1993.
- 2 *Oscilloscopes* Equipment Notes Bulletin 190 SSERC 1997.

Problems with Benedict's Reagent

Negative or unclear results with the use of this, and similar reagents, for the reduction of carbonyl compounds, are reported and discussed.

Appropriate substitution of a chemical by a less hazardous one is a golden rule. Science teachers always did quite a bit of this, long before it became a legal requirement under the COSHH Regulations. Such control measures however, are not much use if the reaction in question then either "doesn't work" or gives unclear results.

Benedict's and Barfoed's reagents were traditionally used, along with Fehling's, in biochemistry and food science to distinguish between different sugars. More recently, Benedict's has been adopted by schools as a safer substitute for Fehling's. It will indeed sometimes do. But, as recent reports and enquiries to SSERC bear out, its use is by no means a panacea. To complicate matters; some time ago we all agreed that ethanal, (Category 3 carcinogen and volatile [b.p. 21°C]) should not be warmed on a water-bath, especially in an open lab.

So, in practicals to illustrate some of the typical properties of alkanals, the answer was to replace it with the less volatile, less hazardous alkanals such as propanal or butanal. These will reduce Fehling's Solution, but only if boiled, whereas the reduction occurred rapidly at room temperature with ethanal. We carried that substitution one stage further, replacing the strongly alkaline Fehling's Solution : *Corrosive* - 2M sodium hydroxide in ready to use solution, nearly 4M in the separate solution B and *Harmful* on account of the copper content - with Benedict's (classed as *Harmful* only).

In Benedict's the alkaline medium is provided by 0.9M sodium carbonate. This is not even classed as *Irritant*. The main risk in this test, possible eye damage from splashes of alkali in the eye, is largely removed by using Benedict's. A major snag is, however, that Benedict's reacts sluggishly with ethanal and not at all with propanal.

REAGENT TEST SAMPLE	Barfoed's	Benedict's	Sandell's	Fehling's
ETHANAL	-ve room temp -ve on boiling	green/yellow upper layer after boiling further boil - red/brown	-ve room temp +ve at 55°C	green/red surface at room temp red/brown on boiling
PROPANAL	-ve at room temp -ve on boiling	-ve at room temp -ve on boiling	-ve at room temp slight red brown on boiling	-ve at room temp red brown on boiling
BENZALDEHYDE	-ve at room temp -ve on boiling	-ve at room temp -ve on boiling	-ve at room temp green with red top on boiling	-ve at room temp green/blue on boiling
PROPANONE	-ve at room temp -ve on boiling	-ve at room temp -ve on boiling	-ve at room temp -ve on boiling	-ve at room temp -ve on boiling
SUCROSE 1%	-ve at room temp -ve on boiling	-ve at room temp -ve on boiling	-ve at room temp -ve on boiling	-ve at room temp -ve on boiling
GLUCOSE 1%	-ve at room temp slight red-brown top	pale green room temp re-brown on boiling	red-brown at 40°C	green/yellow at room temp in 15 min red brown on boiling
FRUCTOSE 1%	slightly red at bottom slightly red at top	yellow/green at room temperature red brown on boiling	red-brown at 50°C	green/yellow at room temp in 15 min red brown on boiling
MALTOSE 1%	-ve at room temp	pale green room temp	red-brown at 50°C	green/yellow at room temp in 15 min red brown on boiling

TABLE 1

It does not always pan out like this. Often when forced to make a substitution we get a pleasant surprise, finding the replacement performs better than the original or, at worst, is only a little inferior in demonstrating a principle but far more safely. In this case though, the combined effectiveness - both of the alkanals as reducing agents and of the copper test reagents as oxidising agents - decreases as they are each substituted by less hazardous alternatives. It would have been nice if only the trend for one of the reactants had gone in the opposite direction! In the tests reported on here (Table 1), four copper based reagents were each used to test for reduction with ethanal, propanal, propanone and benzaldehyde as well as with four sugars (three of which behave essentially as alkanals).

Results: Even Fehling's failed for propanal unless boiled directly in a Bunsen flame. No, we are not recommending schools to use the Bunsen burner in this way with a highly flammable liquid. However Benedict's gives a positive result with ethanal, again only if boiled vigorously in a Bunsen flame. The water bath, and that's what schools will use, did not give a positive reduction for Benedict's by ethanal, never mind propanal. Sandell's reagent works nearly as well as Fehling's over which it has two advantages, (i) a lower alkali concentration - 0.5M as opposed to almost 4M in Fehling's B - (approx. 2M in the prepared reagent) and (ii) that only one solution is needed. Our tests were in fact done with a slightly diluted version of Sandell's reagent with the alkali concentration at 0.4 M.

Certainly, the chemistry of the oxidation of several alkanals and reducing sugars, especially by Fehling's and related reagents has elements of a mystery. Few texts ever show anything other than a schematic equation. For the biologists as well as for interest it would be nice to get an explanation for the different oxidising powers of the three reagents, viz Fehling's (and Sandell's), Benedict's (sodium carbonate) and Barfoed's (weakly acidic). From a simple examination of the test-tube observations one might say that the order of oxidising power is :

Fehling's (& Sandell's) > Benedict's > Barfoed's

Barfoed's is the weakest oxidising agent and is only capable of oxidising the more powerful reducing agents, whereas Fehling's is a stronger oxidising agent, capable of oxidising all the alkanals chosen. The reduction by benzaldehyde appears to be slow, possibly because of its water insolubility. Some mixing of the phases was achieved by vigorous boiling but it might be interesting to use other means of bringing reagent and substrate together (eg by using a solvent in which both water and benzaldehyde are miscible). Benzaldehyde is easily oxidised by air to benzoic acid and one might expect it to be a fairly strong reducing agent.

All of the test reagents contain copper(II) in the presence of a complexing agent or ligand and at different pH. "Reducing sugars" reduce the copper(II) in these reagents to copper(I), the latter being in the form of copper(I) oxide which is reddish brown or brick red in colour. In some cases the initial observation is a greenish/yellow colour formed from the mixture of some as yet unreduced blue copper(II) and a yellowish copper(I) compound. Some folk always expect a red colour. They mistakenly accept nothing less as *positive* when a greenish colour may also be taken as a positive result.

These differences in oxidising power of the three reagents was traditionally put to use by biochemists to distinguish between different groups of sugars, as follows:

Fehling's will oxidise d-glucose, d-fructose, d-maltose (and d-mannose, d-galactose, d-xylose, l-arabinose, d-galactose, l-rhamnose), but not sucrose. *Barfoed's* will oxidise all of the above except the two disaccharides, lactose and maltose. *Benedict's* is intermediate in oxidising strength.

The reason for the varying oxidising powers of the three reagents (four, if you include Sandell's reagent) is down to the Cu(II) being in various media each differing in pH, concentration and in the type of ligand complexing the Cu²⁺ ion. In alkaline solution (Fehling's, Sandell's and Benedict's) the Cu²⁺ would be precipitated as copper(II) hydroxide if it weren't held in solution as a complex. Table 2 shows the pH and the nature of the ligands in each reagent.

REAGENT	pH as measured	Approx. [Cu ²⁺]	Solvent/Medium	Complexing agent
BARFOED'S	4.3	0.3	0.18M ethanoic acid	ethanoate
BENEDICT'S	10.25	0.07	0.9M sodium carbonate	citrate
SANDELL'S	12.59* *raw reading no sodium error correction (ca. +0.03)	0.03	0.4M sodium hydroxide	EDTA
FEHLING'S	13.00* *raw reading no sodium error correction (ca. +0.3)	0.13	sodium hydroxide 3.9M solution B 1.9M in actual reagent	sodium potassium tartrate

TABLE 2

pH effects: The effect of pH on the ease of oxidation is illustrated nicely by another oxidation - that of iron(II). Iron(II) sulphate in dilute sulphuric acid is quite stable to aerial oxidation. But a solution in water, which is closer to neutrality, will soon become oxidised, as evidenced by a faintly rusty suspension. Going to higher pH by adding alkali to a solution of $\text{Fe}^{2+}_{(\text{aq})}$ the bluish/green precipitate of iron(II) hydroxide, $\text{Fe}(\text{OH})_2$, first formed, begins almost immediately to turn brown due to the formation of iron(III) hydroxide, $\text{Fe}(\text{OH})_3$. The redox potentials for the two systems would appear to back up the argument in that $\text{Fe}^{3+}_{(\text{aq})}$ is a stronger oxidising agent than $\text{Fe}(\text{OH})_3$:

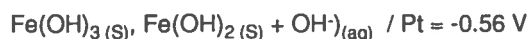

In other words oxidation occurs more easily in alkaline conditions. Table 2 demonstrates that the rank order of these four reagents in oxidising power, coincides with the rank order of pH. *Barfoed's* is acidic and the weakest oxidising agent; *Fehling's*, the most alkaline, is the strongest. Clearly the reagents of concern differ from iron based systems and each other in terms of cation concentration [Cu^{2+}], pH and being complexed with different ligands. These factors, especially the complexing, can greatly shift equilibria and alter E° values, even to the extent of changing the rank order.

Equations for the reaction: The fate of the glucose in these tests is not given in any of our texts. It might reasonably be assumed that the aldehyde grouping of the sugar, $-\text{CHO}$, is simply oxidised to COOH . This can be represented in two simplified schematic half equations:



Adding these two will give the overall equation :

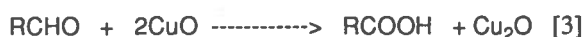

Alternatively, we can use ion-electron half equations and end up with equation [4]:



This might be the equation for the oxidation of an alkanal, though even it will certainly be complicated by side reactions like polymerisation of alkanals which occur in alkaline solutions. The reactions with sugars must include a path somewhat like that in Equation [4] and possibly some others. However this equation does not fit the experimentally found stoichiometry for glucose.

Old man Perkin himself in the *new* (1917!) edition of *Organic Chemistry* (Perkin and Kipping, Chambers) states that:

"... as, moreover, a given quantity (1 molecule) of glucose always reduces exactly the same quantity (approximately 5 molecules) of cupric to cuprous oxide, this behaviour affords a method of estimating glucose by titration."

An old university biochemistry schedule provided a method for the determination of glucose by titration with Fehling's Solution. This also gives a ratio of 5 : 1.

Our summary equation [4] (alkanal to Cu^{2+} ratio of 1:2) thus clearly does not represent reality for glucose. Other more powerful oxidising agents like bromine or dilute nitric acid will oxidise the CH_2OH group at the other end of the chain to a second COOH group. It is unlikely, however, that any of the copper(II) oxidants will do that.

There is scope here for a project on the stoichiometry of the reactions of Fehling's with glucose as well as with alkanals and on the relative oxidising powers of different copper(II) reagents. The order of the reaction could be determined from kinetic measurements and a mechanism proposed.

Summary

The observations as reported, seem to back up our preferred use of *Sandell's* reagent. It is more alkaline than *Benedict's*, but it does "work". In practice the management of the risk is not too difficult. For food tests in the first few years of secondary, *Benedict's*, *Barfoed's* or *Diabur* strips (see Bulletin 187) all can be used.

Organic chemistry and tests for alkanals are not met with until S4 and S5 where *Sandell's* reagent can generally be employed. But note that, with more mature pupils and appropriate precautions, there is no reason not to use *Fehling's* solutions.

* * *

Endpiece

"It's in the book; it must be correct."

I knew a chemistry teacher once, whose approach was exactly the opposite. He used to ask his classes to test out and try to disprove every statement in any of the texts they used. Not many teachers took such an approach, but it is an exceedingly healthy one. It follows the same rich vein as that explored by one of the first among the *proper* chemists (as opposed to the alchemists). Robert Boyle, wasn't it, who promoted the *The Sceptical Chemist*?

Wilson Flood is clearly a latter day Sceptical Chemist. He it was that wrote to tell us that he had never believed what was said in texts, or by his colleagues, about *Benedict's*. His experiences at the bench had only served to reinforce his scepticism. We are indeed grateful to him for encouraging us, and your goodselves, to join him.

BIOLOGICAL BITS

Development officer

Regular readers will know of the perennial problems with our biology workload. For a number of years the Director has also been the Centre's sole biology specialist. The position recently has undoubtedly been relieved by the excellent work of others in third party agencies and projects such as SAPS and the Scottish Biotechnology Education Project (the two now being combined).

All the same, it has been more than difficult trying to tackle Higher Still (hollow laughter off stage?). It is thus gratifying to be able to announce the arrival of a small detachment of part-time cavalry. Kath Crawford (also of Stevenson College, Edinburgh) has been seconded to the Centre two days a week to assist with matters biological. Kath is a member of the Higher Biology writing group and the main author of the materials for Biotechnology Intermediate II. Kath joined us at the end of April and hopefully will be seconded two days a week for at least a year.

Sixth year tips

The sixth-year studies project season is again drawing to a close. It's always a busy time for the Centre because teachers and students seem to sense that none of the idiots in here can resist a challenge. It also keeps us more in touch with schools and on our toes. Hereafter - a few bits and pieces which may prove useful for the next sixth year silly season.

Effects of lead : This one came from a student looking into the effects of heavy metals on enzyme action.

"What is the actual mechanism for the biochemical effects of lead? I need this to round off my project report. None of the curricular support materials seem to give an explanation".

Lead has many, diverse, biochemical effects all of which apparently are harmful. Conversely, no evidence seems to be presented for any possible essential metabolic function for lead. Its atomic structure (two vacant 6p orbitals) means a propensity for forming covalent bonds. This happens readily in biological systems with sulphur atoms in protein molecules. Lead's biological effects therefore all probably relate to its capacity to combine with specific biochemical groups or ligands. These include : sulphhydryl; amino, carboxyl and phenoxy groups as well as imidazole residues. Lead thus might be expected to alter the tertiary structures of biologically active molecules and thus impede or destroy their function. It may also substitute for other, essential, metals in molecules (eg for a metallic co-enzyme) and again alter tertiary structures. Consequently, lead seems capable of changing enzyme activity irreversibly and of destroying structural-functional relationships in biologically active proteins and nucleic acids.

Reference

Adapted from *The Chemical Environment* Vol 6 in the *Environment and Man Series*, Lenihan & Fletcher (Editors), Blackie, 1977, ISBN 0216 90132 4.

Ideas for projects : Fermenters (bioreactors) seem to have gone out of fashion in schools. This may not be too surprising where a commercially designed piece of kit has been bought and much, if not all, of the creative bits are done and dusted. We know however of at least two cases where sixth year students have started instead with a basic glass or polycarbonate vessel and done the rest of the design and make for themselves. They made their own customised lid with the necessary ports for sensors, stirrers or aerators, sampling points etc. Commercially available sensors, dataloggers and controllers were then used to log parameters of interest and control variables affecting growth. In one school the same basic project was given different slants and so counted for both chemistry and biology at SYS level. It was also used to enter for a CREST award and put forward for the Young Biologist of the Year competition.

It's been our view that fermentation is an ideal topic for multidisciplinary, cross-curricular projects and used it several years ago as one of the Case Studies for Technological Studies at Higher. More recent projects have come to our attention. One such of particular note was associated with the Scottish Biotechnology Education Project (since merged with SAPS) and run jointly at Dollar Academy (student - Mairi Wilson), Stirling High (Hannah Bayes) and *Quest International's*, yeast-based, production plant at Menstrie.

This was one of the best education/industry activities we've seen. It is hoped that after something of a lull it will be revived. Dr Jim Hay who was at Quest is now a part-time Biotechnology Training and Development Officer at Falkirk College and it's possible that the new biotechnology education facility there may be involved.

Meantime, anyone who would like help or information on DIY bioreactors, as vehicles for projects either in science or technology courses (or both), will be welcome to contact us at SSERC. We would remind you also that if your school or college is a member that NCBE is a rich source of information, advice and materials for such work. Which reminds us to grovel. Last time round we gave incorrect address details (Oh, the joys of DTPing!) for NCBE. In fact, the only bit we got right was their Website. For the correct details please see the Address List on the inside rear cover of this issue.

Check the POST: We've plugged POST¹ Report Summaries before. Many are particularly useful for biology teachers and their students as succinct updates on currently controversial or fast moving topics. For example some of the subjects covered recently (report number in brackets) have included : *Living in the Greenhouse* (121); *Organophosphates* (122); *Meningitis* (123); *Cystic Fibrosis* (124) and *Non Food Crops* (125). We have permission to copy POST Report Summaries for schools. A more economic way to get them however is via the Web at <http://www.parliament.uk/post/home.htm>.

¹ POST - Parliamentary Office of Science and Technology.

Solder flux fume

Because the Health and Safety Commission (HSC) has set a maximum exposure limit for rosin based solder flux fume, any exposure must be reduced to as low a level as practicable. Substituting a rosin-free solder may be the best option.

Fluxes used in hand soldering have traditionally contained rosin, or rosin based products. When solder is heated to 200 °C, rosin produces *colophony* fume, the main part of which is particulate, consisting of resin acids. Inhalation exposure can lead to asthma, or worsen existing asthmatic conditions. Other hazards include irritation of eyes and upper respiratory tract and allergic contact dermatitis. No threshold level can be identified below which there is little risk of workers contacting occupational asthma [1].

Until 1996, the HSE had under COSHH set occupational exposure standards (OES) for rosin-based solder flux fume. Because it was an OES, an employer did not have to act to prevent exposure provided that the concentration was below the OES level. We are not aware of any measurements of fume concentration ever having been made in schools, but we are aware that several employers implemented some of our recommended controls [2] such as substitution and natural ventilation.

Recognizing that no safe level can be identified, HSE withdrew the OES for rosin-based colophony fume in 1997. Now this year (1999) they have set maximum exposure limits (MEL) [3]. This means that local exhaust ventilation (LEV) must be used whenever rosin-based solder is being worked with.

The risk may no longer be dismissed as small. The significance of being assigned a MEL is that exposure to

Significance of OESs and MELs

OES : Occupational Exposure Standard
MEL : Maximum Exposure Limit

Applying OESs : By staying below the level, you are complying with the law. (Of course it is good practice, although perhaps not a legal necessity, to try to reduce an exposure to any substance with an OES to as low a level as possible and very much less than the limit.)

Applying MELs : To comply with the law you have to :

- keep any exposure below the level, and
- do whatever is reasonably practicable to further reduce exposures (implying that local exhaust ventilation (LEV) must be used if it is reasonably feasible to do so, and that air sampling may be needed).

Rosin-based solder flux fume MELs

8-hour TWA:	0.05 mg m ⁻³
15 minute reference period:	0.15 mg m ⁻³
Notation:	Sensitiser

rosin-based colophony must be reduced as far below the MEL as is reasonably practicable. Because it is practicable to employ local exhaust ventilation - the technology exists and although the extractor machines are expensive, the cost is not outrageously high - schools must now use LEV with this type of work.

Another implication of MEL status is the need for air sampling to check that exposures are below the MELs. The standard method with gas chromatography [4] is beyond the facilities of schools, or skills to be expected of staff. Any such sampling would have to be done by outside specialists.

Control by substitution

The avoidance of rosin based solders containing natural or modified rosin is recommended. Responding to the the better understanding of the problems with natural rosin-based products, solder manufacturers have been developing rosin-free solders. We have tested one such product from Multicore called *Ecosol 105*, which has a fully synthetic, colophony-free flux. *Ecosol 105* has been designed for hand soldering. Our tests indicate that the 5-core version is as easy to work with as natural rosin-based solder. We recommend that you switch to Multicore solder wire with 5-core, *Ecosol 105* flux for soldering operations (Table 1).

We disagree with Rapid Electronics that *Hydro-X water soluble fluxed solder* is suitable for educational applications [5]. Whilst it is suitable for hand soldering, the processes leaves behind water soluble residues which must be removed immediately. If the residues are not

Supplier	Weight	Order code	Price
Farnell	250 g	454-072	£10.93
	500 g	454-280	£15.36
RS	250 g	295-4814	£16.23
	500 g	295-4820	£24.23

Table 1 Suppliers, order codes and prices of 0.7 mm dia., 5-core, solder wire with *Ecosol 105* flux.

Ecosol 105

Fume hazards and precautions : Avoid excessive inhalation of the flux fumes. These are irritating to the throat and respiratory organs. Suitable fume extraction equipment should be used to extract flux fumes away from operators.

Multicore Product Data Sheet 704 2/98

washed off, they absorb water from the atmosphere. This eventually can cause the solder joint to become unsound. Because the washing stage may be omitted in schools from lack of time, or from not appreciating its significance, *Hydro-X* is not recommended by us.

The Material Safety Data Sheet for *Ecosol* warns users that, as the fumes are hazardous, fume extraction should be used. How trusting should we be in substituting a synthetic flux for natural rosin?

At the present time we just don't know whether rosin substitutes are reasonably safe. What we are certain about is that rosin-based products are unsafe. There is no threshold level below which they can be used without risk. So how should we play this?

- 1 Be sceptical. Presume that fume from all solders is hazardous.
- 2 Substitute *Ecosol 105* for rosin-based solders.
- 3 Do not inhale the flux fumes.
- 4 Use fume extraction equipment.

What is the advantage of jumping to Ecosol, about which little is known? Why not stick with the devil we know?

There are legal reasons which make it difficult to work with a substance that has been given a MEL. You may have to show that you have done everything reasonably practicable to reduce exposure. This is an onerous requirement, one not easily met.

Then if rosin-free solder such as Ecosol has not been assigned an OES or MEL, do we really need to use fume extraction? After all, precious few schools have been using LEV with rosin-based solder!

The law requires you to do a risk assessment and devise whatever controls are reasonably practicable to reduce the risk. Your main source of information on synthetic-rosin solder is the manufacturer's Material Safety Data Sheet. Because this instructs you to use fume extraction, and knowing the potency of natural rosin-based products, the sceptical, scientific and canny mind advises that fume extraction is needed.

Fume extraction

In workplaces where hand soldering takes place, three types of LEV are commonly used to remove solder fume from the work area :

- 1 *Bench mounted extraction* - A cowl fitted over the work area which connects through ducting to an extractor fan and filtration unit. The extracted air may

be either pumped out of the building, or returned to the work area having been cleaned by passing through filters. This type of LEV is also known as an *arm extraction system*.

- 2 *Tip extraction* - A small nozzle fitted very close to the tip of the iron which links via flexible tubing to an exhaust fan and filtration unit. A high velocity air intake draws fume into the nozzle.
- 3 *Fume absorber and displacement* - A small, free-standing unit which draws solder fume through a foam type, activated-carbon filter. Some of the larger particulate is trapped in the filter. The smaller particulate and gas is blown away from the face of the worker into the workplace.

The effectiveness of these three systems in reducing personal exposure has been assessed by the HSE. Their results [6] (Table 2) indicate tip extraction to be the most effective form of LEV for hand soldering. Fume absorber units may be counter-productive because they return the majority of the fume to the workplace. Fume absorber and displacement units tested by SSERC in 1995 [7] are not now recommended.

The results also show that tip extraction is neither perfect nor foolproof. Difficulties with the method include :

- 1 *Blockage of tubing* - Gummy residues are deposited in the steel tube and particulate may be laid down wherever the airflow is poor, such as at corners, or joints, or sudden changes in diameter. The tubing should thus be inspected and cleaned regularly.
- 2 *Air velocity* - There is an optimum value for capturing most of the fume. It tends to fall if the tubing becomes constricted because of deposits, or because the filter becomes dirty with ageing. If the air velocity is too low, it fails to capture all the fume. If the air velocity is too high, it cools the tip.
- 3 *Nozzle position* - The nozzle can slip out of position, reducing its ability to capture fume.
- 4 *Soldering technique* - Fume is emitted from a solder joint for a period of about one or two seconds after the removal of the iron. The tip and its attached nozzle should linger close by the cooling joint to capture this fume. Users would have to be trained to learn this technique.
- 5 *Filter efficiency* - Filters have to be replaced periodically.

Type of LEV	Percentage of personal exposures below 8 h MEL
No LEV in use	22%
Fume absorbers	56%
Bench mounted extraction	69%
Tip extraction	85%

Table 2 Personal sampling results of HSE surveys (Pengelly *et al* 1998) comparing the relative efficiencies of types of LEV in reducing exposure to solder fume in workplaces where hand soldering is undertaken.

Product description	Order code	Price
<i>Portable fume extractor</i>		
Purex 7000/2 Tip Electric 2-station portable electric tip extraction machine complete with filters	070320	£314.10
Iron adaptor kit (Weller) (specify kit for make of iron)	100066	£16.83
Silencer for 2 Tip Electric	150905	£34.96
Replacement HEPA filter for 2 Tip Electric	110675	£91.73
<i>Static fume extractor</i>		
Purex 8000/10 Tip System (10 station tip extraction machine)	080010	£1212.75
Purex 8000/20 Tip System (20 station tip extraction machine)	080020	£1351.56
Iron adaptor kit (Weller)	100060	£16.83
Extended On/Off Tap Kit	100130	£13.72
8000/10 Tip HEPA Filter	114500	£221.18
8000/10 Tip Pre Filter (4 off)	202260	£49.88
8000/20 Tip HEPA Filter	114500	£221.18
8000/20 Tip Pre Filter (4 off)	-	£49.88
Installation and certification (10 stations)	-	£373.12
Annual maintenance and re-certification of Purex 8000/10 Tip extraction system	-	£275.00

Table 3 Products and costs for installing portable or static solder fume extraction using Purex systems from Hi Tech.

Over and above these difficulties are the problems caused by students tampering with equipment and LEV in schools is at risk of being vandalised. A fixed installation would be at greater risk of abuse than a portable system, which would only be brought out when needed.

Another advantage of a portable LEV is that it can easily be moved from one classroom to another, or placed in the prep room for the use of staff.

Therefore the type of LEV we recommend is a **portable system with tip extraction.**

There is one, recently designed, portable system which meets our requirements. This is the *Purex 2-Station Electric Solder Fume Extraction System* from Hi-Tech UK. A short review appears overleaf.

A summary of the costs of providing solder fume LEV is shown in Table 3. A 2-station portable system would necessarily comprise an extraction machine, two iron adaptor kits and a silencer at a total cost of £383. Filters costing £92 would need replacing at least every year, perhaps more often if heavily used.

If a 10-station static system were to be installed, the total cost of the system including fitment of ducting is £1892. The extraction machine is easily transported from one room to another because it is on wheels. Permanent ducting could then be installed at perhaps £500 a room and the extractor machine taken to the place where soldering is to be undertaken. The annual cost of replacing the filters and routine maintenance is around £546.

It is a legal requirement of regulation 9 of COSHH that an LEV plant should be examined and tested at least once every 14 months. Technical information on how to proceed should be sought in the first instance from the company who supplied the plant.

Summary

- 1 If hand soldering with rosin-based solder, then LEV must be used and it must be shown to be effective.
- 2 You are not advised to use solder wire with rosin-based flux - whether natural or modified. Substitute a wire with a rosin-free flux. One flux we can recommend is *Ecosol 105*. Suppliers are listed in Table 1.
- 3 Even when soldering with rosin-free flux, you are advised to capture the fume.
- 4 Tip extraction has been shown to be more effective than other forms of LEV in removing fume when hand soldering.
- 5 Our recommended type of LEV is a portable system with tip extraction. A suitable system is listed in Table 3.

References

- 1 *Rosin-based solder flux fume Criteria document for an occupational exposure limit* EH65/31 HSE 1997
- 2 *Solder fume control* Bulletin 186 SSERC 1995
- 3 *Occupational exposure limits 1999* EH40/99 HSE 1999
- 4 *Methods for the determination of hazardous substances Resin acids in rosin (colophony) solder flux fume* MDHS83 HSE 1997
- 5 *Hydro-X water soluble fluxed solder* Product description Electronic Components Catalogue Rapid Electronics 1999 p. 440
- 6 *Workplace exposure to rosin-based solder flux fume during hand soldering* Pengelly I, Groves J, Simpson A, Northage C. *Ann. occup. Hyg.* Vol. 42 No. 5 pp. 295-302 1998
- 7 *Portable fume displacement units* Equipment Notes Bulletin 186 SSERC 1995

Purex fume extractors - portable and static

Purex 2-Station Electric Solder Fume Tip Extraction System 7000/2

Technical specification

Dimensions	Height	= 220 mm
	Diameter	= 260 mm
Weight	10 kg (including filter)	
Portable	Yes	
Enclosure	Epoxy coated steel	
Extraction ports	2	
Filters	Chemical : neutralizes acidic gas	
	HEPA ¹ : removes particulate fume	
Supply voltage	230 V	
Power rating	600 W	
Sound rating	52 dB(A)	

Description

Air and fume is drawn into the nozzle at the iron tip at a flowrate of 30 litres per minute. A one metre length of heat resisting silicone rubber tubing connects from the short length of stainless steel tubing on the iron to an inlet port on the enclosure of the extraction machine.

The flowrate is controlled electronically and cannot be adjusted by the user.

The extractor has a chemical filter which neutralises the acidic gases in the airflow and a HEPA filter which removes the particulate. According to the specification, this collects 100% of particles to 0.3 micron and 95% of particles to 0.01 micron. The net effect is that 99.997% of fume is collected. The filtered air is then released back into the workplace.

The silencer is fairly essential. It acts as a damping baffle preventing vibration being transmitted to the worksurface. With it in place, the sound level is reduced by about 9 dB. From our own tests, we found that the sound level from a machine with a silencer was 50 dB at a distance of 1 m, falling to 44 dB at 3 m. These levels are unlikely to cause annoyance.

Because the installation is very simple and takes little time, we reckon that the inconvenience of using the extractor is minor. In consequence this is unlikely to deter people from using it.

The appliance was inspected and tested for electrical safety and found to comply with recognised safety standards.

Assessment

On the basis of the technical specification and from operational trials at SSERC, the Purex 2-station portable solder fume tip extraction system would seem to be suitable for use in schools and colleges.

¹ HEPA filter = High efficiency particulate air filter

Purex 10-Station Electric Solder Fume Tip Extraction System 8000/10

Technical specification

Dimensions	Height	= 714 mm
	Width	= 455 mm
	Depth	= 455 mm
Weight	39 kg	
Portable	No, but transportable on wheels	
Enclosure	Stainless steel	
Extraction port	Connects to 32 or 50 mm dia. duct servicing 10 solder stations	
Filters	Collection tray : removes large particulate	
	Pre-filter : protects main filter	
	HEPA : removes particulate fume	
	Chemical : neutralizes acidic gas removes odour	
Supply voltage	230 V Power 0.35 kW	
Sound level	47 dB to 53 dB at 1 m 45 dB at 3 m	

Description

The HEPA filter collects 100% of particles to 0.3 micron and 95% of particles to 0.01 micron. Because air is drawn upwards through this filter, heavy particulate is removed by gravity, dropping into a collection tray. A 2-stage chemical cartridge removes remaining gases, neutralizing the acidic part. The filtered air is then released back into the workplace.

The flowrate is controlled electronically. The user can set the controls, or use default settings. We found the instructions to be rather cryptic. It was not clear how to proceed. The membrane keypad can be disabled preventing unauthorised use.

The extractor connects to 50 mm diameter ducting which is permanently installed round the workbenches. Up to ten ports may be fitted with the 8000/10 unit. For convenience, an Extended On/Off Tap Kit should be fitted to each port which allows them to be switched on or off independently. A one metre length of silicone rubber tubing connects from the port to a stainless steel tube fitted on the iron.

The appliance was inspected and tested for electrical safety and found to comply with recognised safety standards.

Assessment

On the basis of the technical specification and from operational trials at SSERC, the Purex 10-station static solder fume tip extraction system would seem to be suitable for use in schools and colleges. In places where installations are subject to vandalism, a portable system is to be preferred, because it can be stored away when not in use.

TECHNICAL NOTES

MOSFETs, diodes and photodiodes

A teaching order with the Edinburgh University / Motorola chips and JJM Project Board overlays is described.

This is the teaching order thought up by Alex Munro, PT Physics at Lossiemouth High School, when he designed the overlays for the Project Board made by his company, JJM Electronics. It may be used as a teacher demonstration to introduce the MOSFET and other semiconductor devices. Or it may be incorporated within a resource based, learning package.

The Project Board (Fig. 1) has a 16 pin DIL socket for accepting the Edinburgh University / Motorola Teaching Chips. There are sixteen 4 mm socket outlets connecting to each of the pins on a Teaching Chip. The sockets are arranged in sets of four around a square representing the block of silicon on which the integrated circuits have been built. Card overlays may be inserted into the square. Each has a line drawing with information about structures to be found on the silicon.

The diagrams on the right hand side of each page are copies of overlays, drawn to actual size, which fit into the Project Board. They should be used in the sequence shown, stacking one on top of the other.

The commentary in the left hand column gives information about each overlay and instructions on what to do.

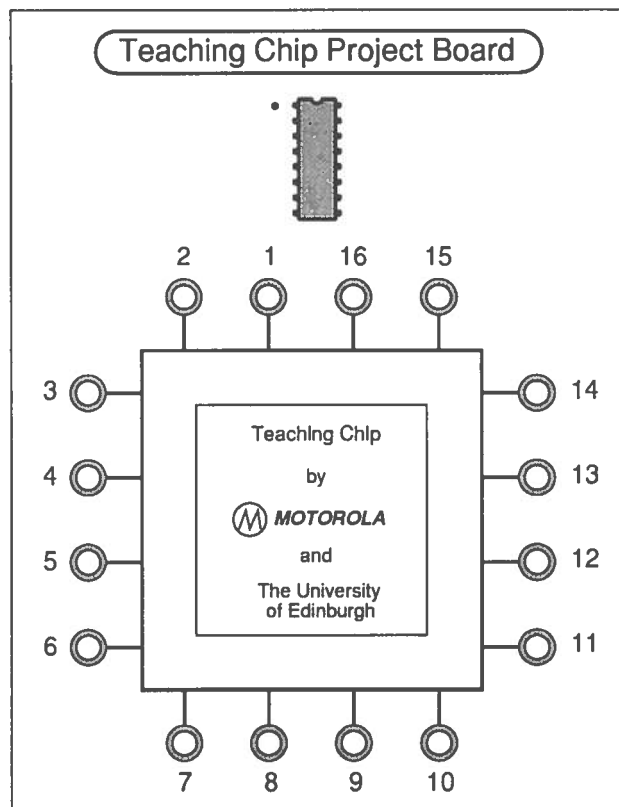
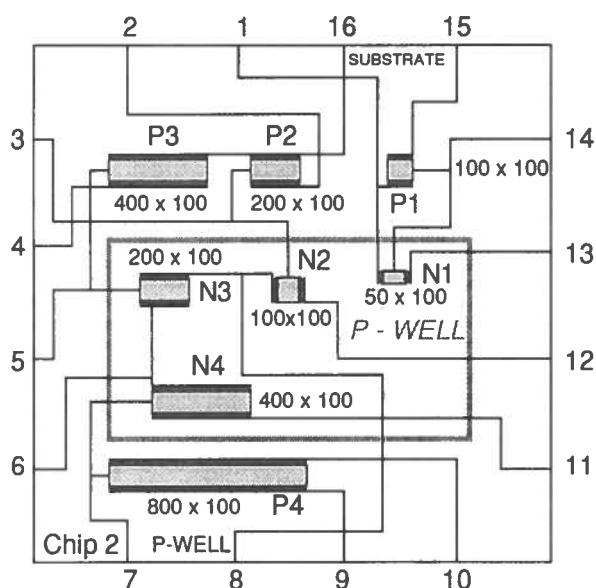

Figure 1 The JJM Project Board. The square represents a silicon chip whose overall size is 2.5 mm. Card overlays fit inside the square with information about structures on the silicon.

N-channel MOSFET

Overlay with plan of every structure :

- 1 Transistors are identified as rectangular blocks in the plan. Identify eight transistors in total - four n-channel and four p-channel.
2. The fine lines represent metal conductors connecting transistors to the sixteen, peripheral, solder pads, numbered 1 to 16.
3. The underlying material of the silicon chip is n-type silicon.
4. The dimensions of the silicon chip are 2.5 mm by 2.5 mm. This should be confirmed by looking at a chip.
5. The dimensions of each transistor are given in microns. For instance N3 is marked 200 x 100, implying that N3 has a width of 200 μm and length of 100 μm .
6. All of these structures may be seen under a microscope with x40 magnification. Use reflected illumination from either bright skylight or a bench lamp.



Overlay with the four n-channel transistors :

- 1 The four n-channel transistors are built on a well of p-type silicon implanted into the n-type substrate. This p-well should be regarded as the localized substrate for the n-channel transistors.
- 2 The p-well must be reverse biased with respect to the n-type substrate. This is done by connecting pin 8 to 0 V and pin 16 to the positive supply.
- 3 For the same reason, all other types of digital integrated circuit need to be biased.
- 4 Transistors N2 and N3 share a conductor to pin 8. Because this conductor is bonded to the p-well (or p-substrate) it defines the sources of N2 and N3.
- 5 The source and drain on N1 are interchangeable. N1's source may be either pin 2 or pin 13.
- 6 With N4 it is preferable to make pin 6 the source and pin 11 the drain.
- 7 The four transistors are identical apart from their widths.

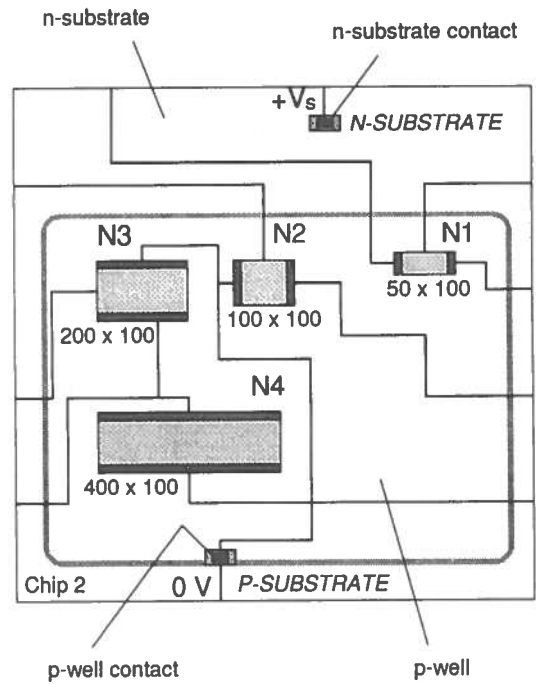

Overlay with a plan of N2 :

- 1 The gate resembles a parallel plate capacitor in structure. A rectangular area of metal overlies a layer of silicon oxide sitting on the semiconductor substrate material - hence the acronym *MOS* for *metal on oxide on semiconductor*.
- 2 Connect up the transistor to a source of supply with a fixed, positive voltage on the drain and a variable, positive voltage on the gate. Monitor the gate voltage with a voltmeter and drain current with a microammeter (Fig. 2).
- 3 Set the gate voltage to 0 V and gradually increase its value, noting that the transistor starts to conduct when the gate voltage reaches 1.8 V.

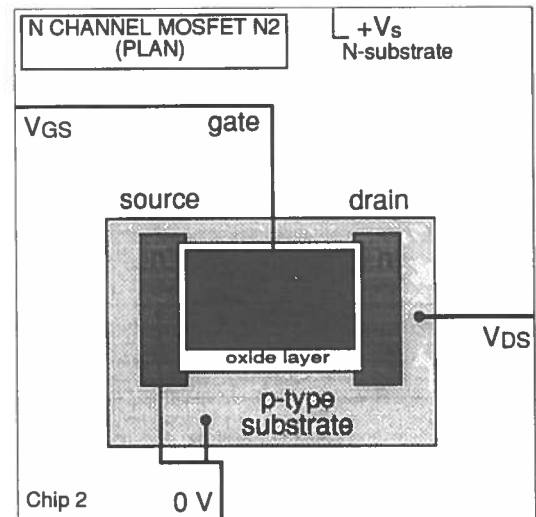

Overlay with section of N2 :

- 1 The source and drain are regions of n-type silicon that have been implanted into the p-type substrate.
- 2 The source and substrate are electrically interconnected.
- 3 Gradually ramp up the gate voltage explaining that this sets up an electric field between the gate and p-type substrate. Majority charge carriers in the substrate, called holes, are induced to move from the vicinity of the oxide layer deep into the substrate. Conversely minority charge carriers in the substrate, electrons, are induced out of the depths of the substrate up towards the oxide layer. As the field strengthens, the p-type substrate material next to the gate oxide inverts to n-type silicon, opening up the channel.

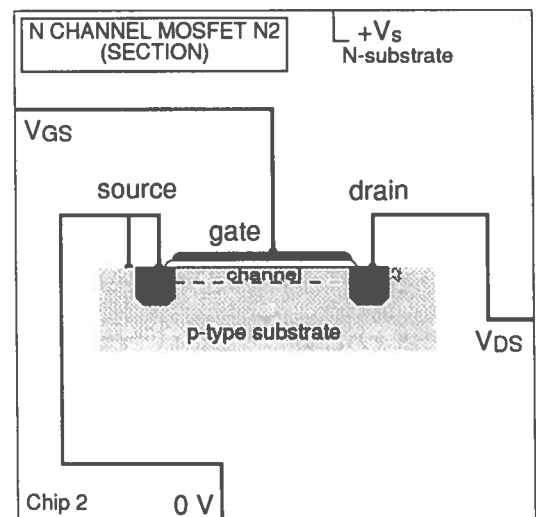

Overlay with n-channel MOSFET symbol for N2 :

- 1 Explain that this is the standard symbol representation of the n-channel MOSFET.
- 2 Relate different parts of the symbol to the structure of a MOSFET shown on the section diagram.
- 3 Explain that the source and substrate are electrically bonded together and all of the potential differences are referenced to the source :
 V_{GS} = p.d. between gate and source
 V_{DS} = p.d. between drain and source

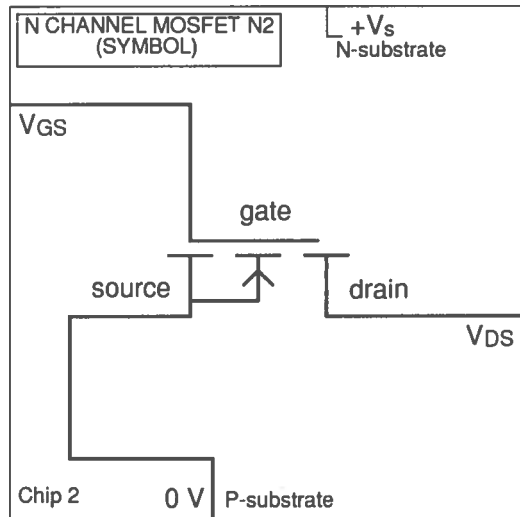

Overlay with upright n-channel MOSFET symbol for transistor N2 :

- 1 Explain that the symbol is normally drawn with this orientation. In circuit diagrams, the 0 V rail would be shown as a horizontal line along the bottom of the circuit diagram; the positive supply rail would be shown as a horizontal line along the top of the diagram. Relate the overlay to the conventional circuit diagram (Fig. 2).
- 2 Set the gate voltage such that the drain current is 5.0 μ A.
- 3 Switch off the power supply without altering the potentiometer and disconnect the connections to pins 3 and 12 on the Project Board.

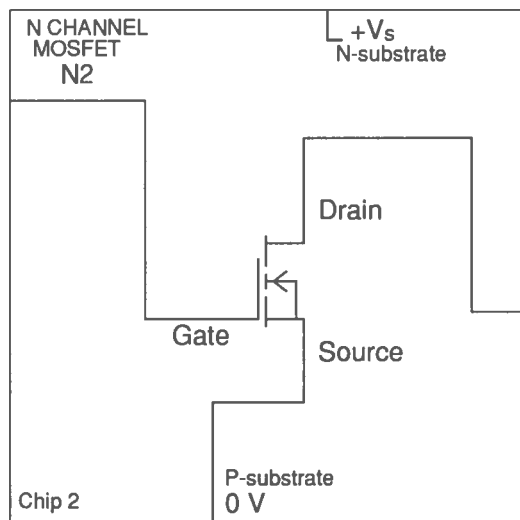

Overlay with n-channel MOSFET symbol for N3 :

- 1 Finally observe the performance of transistor N3 relative to transistor N2. Connect the potentiometer output to pin 5 so that exactly the same value of gate voltage is applied to this other transistor. Connect the supply voltage via the microammeter to the drain.
- 2 Switch on the supply voltage. The drain current through N3 should be twice the current that flowed through N2 because the channel width has doubled, i.e. 10 μ A exactly.

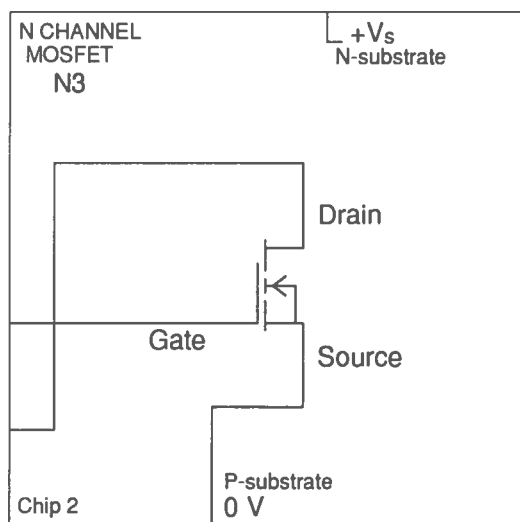

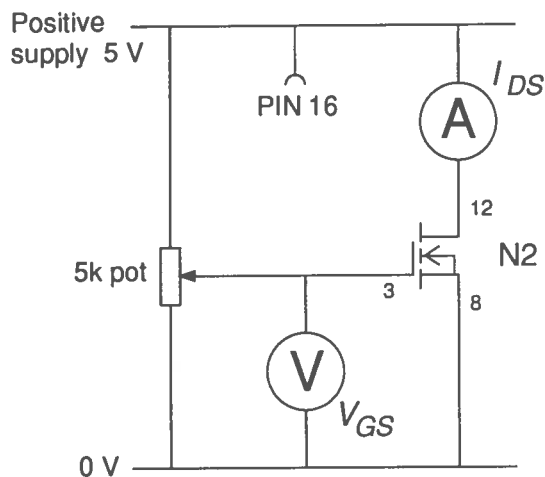

Figure 2 Circuit diagram for showing how the MOSFET is controlled by the p.d. between gate and source. The microammeter should have a resolution of $0.1 \mu\text{A}$.

Final remarks

By using plans, sections and symbols, the teacher can describe how MOSFETs are constructed and explain how they operate.

Because the MOSFETs on Chip 02 of the Edinburgh University / Motorola Teaching Chip set are visible under a microscope, students can relate what is seen to information provided.

By comparing the performance of similar transistors with different gate widths, students can appreciate the role of scaling in electronic circuit design. Shifting from one overlay to another facilitates such comparisons.

Students should be able to appreciate that complex, digital, integrated circuits in computers and elsewhere consist of large numbers of devices, densely packed together and greatly scaled down in size, but resembling the transistor structures on Chip 02.

The Project Board with set of overlays is available from JJM Electronics at £12.85. The set of four Teaching Chips costs £10 and may also be bought from JJM, or from SSERC. Individual chips are now available from SSERC at £4 each.

EQUIPMENT NOTES

PASCO interfaces and the iMac

Several schools have recently contacted us to ask whether the iMac computer will support PASCO interfaces operating with Science Workshop. PASCO engineers are trying to resolve this problem, as the following messages testify:

"Tuesday, March 09, 1999 :

Dear iMac Enthusiast,

Apple took many manufacturers by surprise when they eliminated serial ports from their new iMac computers. PASCO is currently developing a revision of our Science Workshop 500 Interface via a commercial serial to USB adapter. The revision is expected to be available June 1st, 1999, and can be downloaded from PASCO's web site at www.pasco.com.

* * *

Wednesday, 17 March, 1999 :

Dear iMac Enthusiast,

Today we received an iDock. This device plugs into the USB port of an iMac then resides under the iMac as a swivel base. The iDock has three USB ports, two serial ports and a parallel port. Installation took us about 10 minutes including restarting the iMac. The iDock does require Mac OS 8.1 or later.

We have tested both the 500 and 750 interfaces. Both were found by Science Workshop and were able to take data. This initial success was very encouraging, and we will continue to test the iDock extensively. The iDock has a street price of about \$180.00. This is a bit pricey for this one application, but this does bode well for future hardware solutions. The company that makes the iDock, Compucable, is working on a simple USB to serial converter. As soon as it is available, we will test it too. I would like to reiterate that we have not tested all possible configurations, but so far things are looking very promising.

Website address : <http://www.compucable.com>"

No comment

"Sometimes, paranoia's just having all the facts"

William Burroughs quoted in The Scotsman's "Thought for the day"

Comment

Remember our earlier suggestions for rarified and erudite titles for MEd theses? Reading the results of recent research by the Centre for Science Education at Leeds suggests another topic. (cont./next col.)

It seems that the Leeds study found that the National Curriculum was too restrictive thus making Science teaching very effective but also excessively boring. This suggests a research thesis along the lines of :

"Contemporary English Science Education and the National Rugby Union Fifteen : A comparative study."

* * *

SAFETY NOTES

Health and safety policies

As part of our programme of Health and Safety training we have run courses in the management of risk and on formulating operational policy documents. The latter are in our view often more effective when there has been a modicum of discussion based on realistic case studies. If this is then followed up in allowing course participants to draw up at least a list of headings for policies of their own then the better the chances that they will follow matters up once they're back in their own schools.

Nonetheless, we recognise that you are all ridiculously busy folk. So, we've decided to make copies of these policy frameworks available more widely. We have three in total at present, two are joint or whole department documents - one for science subjects, the other for technological subjects. These two frameworks are tartanised versions based on a science department policy document put together for our sister organisation CLEAPSS, and for ASE use, by Dick Orton (whose original and considerable contribution is gladly, and most gratefully, acknowledged).

The third document owes more to ideas from the Education Service Advisory Committee of the HSC and from practitioners. It provides a framework for a whole school policy and has evolved out of courses on health and safety policy writing for school heads or other members of senior management teams.

All of the policy skeletons come in a "fill in the gaps" format. If there is sufficient interest we can make them available on disk as Microsoft Word documents or in rich text format. (Anyone volunteering to translate them into AppleMacese earns our undying allegiance but we can afford little else). Some time ago master copies of the science policy were circulated to members of the Scottish Science Advisory Group and at some time we may make at least two of them available on our website.

If you wish to have hard copies of any or all of these three documents, send us an SAE and a token £2 to cover copying, post and packing.

Fume cupboard testing

Allen Cochrane, Senior Associate (Chemistry) has produced a short guide to performance testing of fume cupboards. This covers both fixed (ducted) and filter (mobile) fume cupboards and deals not only with measuring face velocities in both types but also with challenge tests on filters in the mobile types. Copies of this guide were sent out for consultation via the Scottish Technicians' Advisory Group. Copies of the finalised version are however available on request from SSERC at £3 to cover copying and postage costs.

Be safe! reprinted, again

The Scottish edition of the ASE publication *Be safe!*, gives practical, no-nonsense, advice on health and safety issues for science and technology activities in Environmental Studies 5-14. Since its first publication it has now been reprinted twice. This latest reprint means that both we and ASE Booksales again have stock. Price depends somewhat on the order size but from SSERC, to our members, is generally £4-95 for a single copy and £4.50 per copy for more than five copies (ie 6+ copies).

Clear phenolic disinfectants

Our preference in recent years, and that of many other practitioners, for a disinfectant in discard jars or spillage kits has been the clear phenolic type. They are less toxic than the lysol or sudol of the good ol' days and, as their name suggests, don't go milky when diluted with water but stay relatively clear. They have a fairly wide antimicrobial spectrum (although unlike chlorine based types, they are at best only weakly sporicidal or antiviral).

Mainstream educational suppliers used to sell clear phenolics but for some reason withdrew them a while ago. Finding alternative suppliers, willing to sell in reasonable minimum quantities, has apparently been a difficulty for many schools. We've managed to find a couple of Scottish firms who can meet this need.

A. & J. Beveridge of Edinburgh (see Address List) sell a 5 litre container of *Stericol* (ref. 088146) at £11.25 after educational discount (no carriage charge). R. & J. Woods of Paisley stock both *Hycolin* (ref. CHEMHycolin 5 litres £15.24) and *Stericol* (ref. CHEMStericol, min. 2x5 litres, £31.88).

* * *

Safety snippet

R u a snorrer?

Do you have a problem with obstructive apnoea syndrome or OSAS (snoring to the rest of us)?

Apparently the Medical University of Uppsala has recently demonstrated that the incidence of snoring rises with increased exposure to organic solvents. So, one way to stop snoring is to decrease your exposure to organic solvents.

Alternatively, is this a novel way to determine excessive exposure to solvent vapours?

HAZARDOUS CHEMICALS

An Interactive Manual for Science Education

Use your Web Browser to surf the Health & Safety information on our new CD - an interactive version of the Hazardous Chemicals Manual

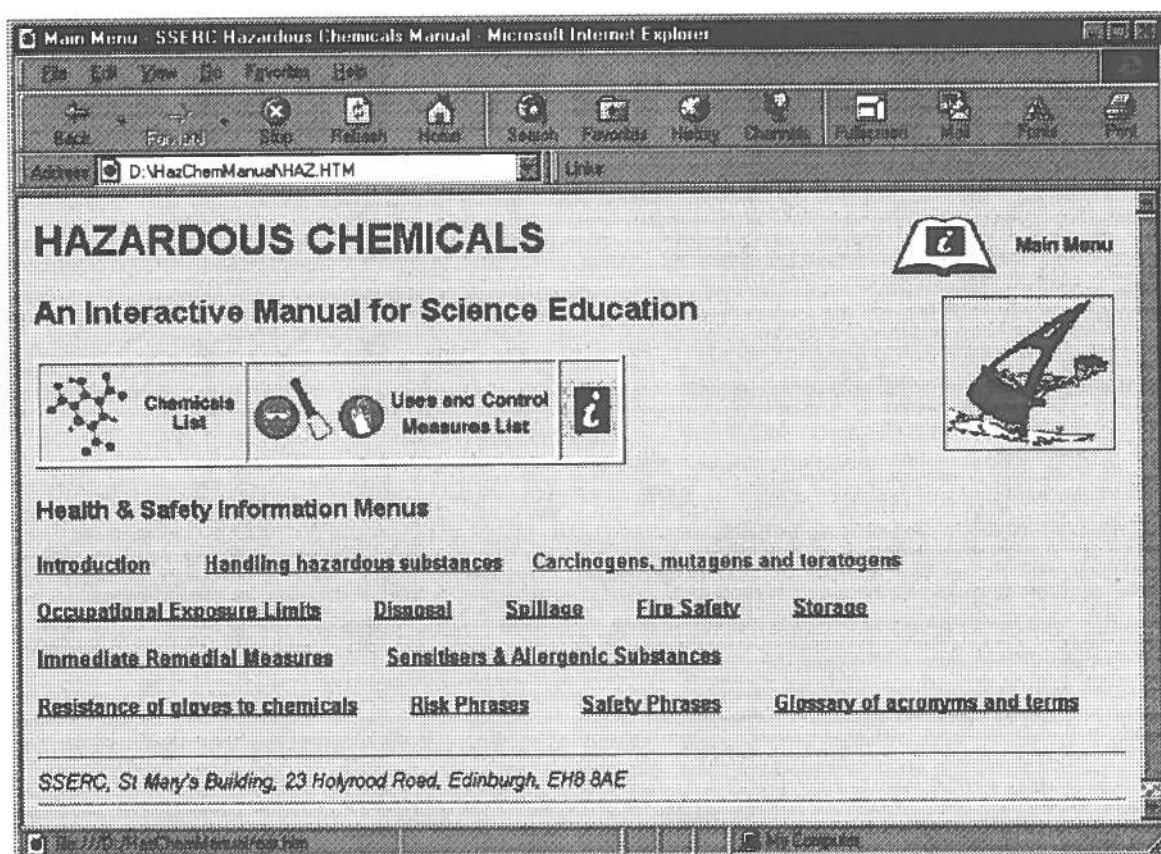

260 Chemical Groupings **Interactive** **Over 15,000 links**

Ideal example of the use of ICT in Science

Uses & Control Measures for Model Risk Assessments

Updating Service

Accompanies HAZARDOUS CHEMICALS - A Manual for Science Education

Discounts for SSERC and CLEAPSS Members

Can be used on PC, Mac and Acorn with suitable Web Browsers

PRICE LIST - Includes postage, packing & Site Licence. Add VAT at current rate.

Members

Others

Interactive Manual for Science Education - special price to holders of hard copy	£35.00	£85.00
Interactive Manual for Science Education - one-off purchase of CD only	£75.00	£180.00
HAZARDOUS CHEMICALS - A Manual for Science Education - hard copy, no VAT	£50.00	£120.00

TECHNICAL NOTES

A simple light gate

Designing a light gate is usually far from simple. A complex circuit design may well be preferable to the primitive one given here for operation with Unilab's *Motion QED*.

Light gates are notoriously difficult to design for reliable operation in all circumstances. Twenty years ago the sensor might have been a single phototransistor. Nowadays you get a photodiode, op-amp, comparator and digital logic device in the light gate's circuit. Is the complexity needed? I guess so! Modern laboratory timers can have resolutions of 10 μ s or 100 μ s. The light gate must match this speed.

So when we had a request for a simple light gate circuit to switch a Motion QED, not requiring an external power source, with inexpensive parts, and which would operate under all conceivable lighting conditions, I knew I was on a loser. It was mission impossible. Something would have to give!

Here then is how the request was answered. The technical details apply only to the QED timer; other instruments may not be triggered in the same way.

- 1 *Motion QED input* : The input logic changes from low to high when a rising signal exceeds 2.8 V. It changes from high to low when a falling signal drops below 1.9 V. This range is too great for a single-junction photovoltaic device. If a photodiode in photoconductive mode were to be used, additional circuitry and power would be required.
- 2 *Sensor* : The sensor type is a photo-darlington transistor because of its large, dynamic range (type MEL12, Maplin product code HQ61R, price £1.61). When MEL12 is connected across the QED input (collector to RED terminal, emitter to BLACK terminal) (Fig. 1), values for the input voltage and response times are as listed :

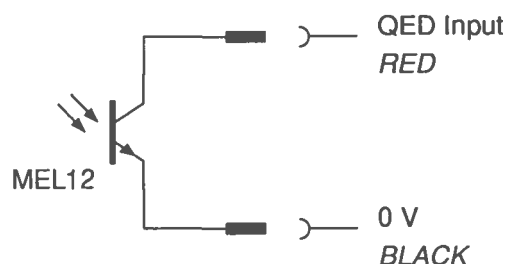

Figure 1 Circuit showing sensor directly across QED input.

- Dark illumination	4.9 V
- Subdued room light (320 lux)	0.58 V
- Radiation from a lenticular bulb for ranges between 5 cm and 20 cm	0.55 V
- Rise time	10 - 20 ms
- Fall time	< 2 ms

Actual time delays are less than half the rise time delays, being the time for the QED input signal to rise from 0.55 V to 2.8 V. Ignoring the fall time delays, QED event times have, with MEL12, a random uncertainty of between 5 ms and 10 ms, applied systematically (Fig. 2). This arrangement is not satisfactory.

- 3 *Pull-up resistor* : The significant rise times show that the QED's internal circuit is unable to pull its own input to logic high at a suitably fast pace. This condition indicates that an external +5 V power supply should be used. A 10 k Ω dropping resistor is also needed. 10 k Ω has been found by testing to be the most suitable value. With this modification (Fig. 3), input voltage levels on the QED and rise times become :

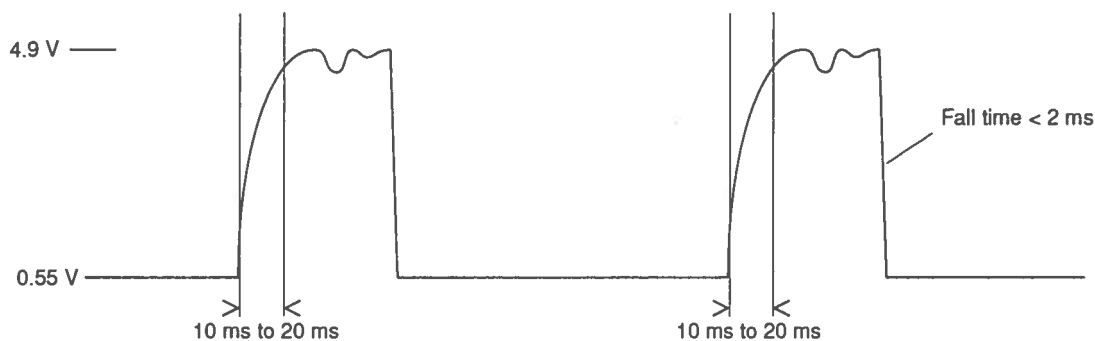

Figure 2 Typical rise and fall of QED input signal with MEL12 connected as in Figure 1.

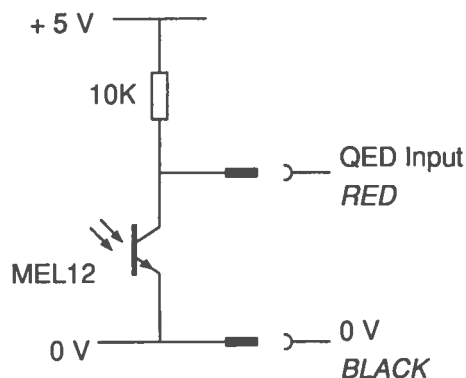

Figure 3 Circuit showing sensor with pull-up resistor to an external supply source.

- Dark illumination	5.0 V
- Radiation from bulb	0.65 V
- Rise time	3.2 ms
- Fall time	0.5 ms

4 *Ambient lighting* : Generally all types of light gate can be triggered by ambient lighting, particularly direct sunlight or high intensity diffuse daylight. To minimise the effects of ambient sources, the sensor should be mounted in a small, opaque box with a small, circular aperture. Suitable enclosures are small diameter metal tube and a black, 35 mm film canister (Fig. 4).

Surfaces around the source, detector and mask should be matt black.

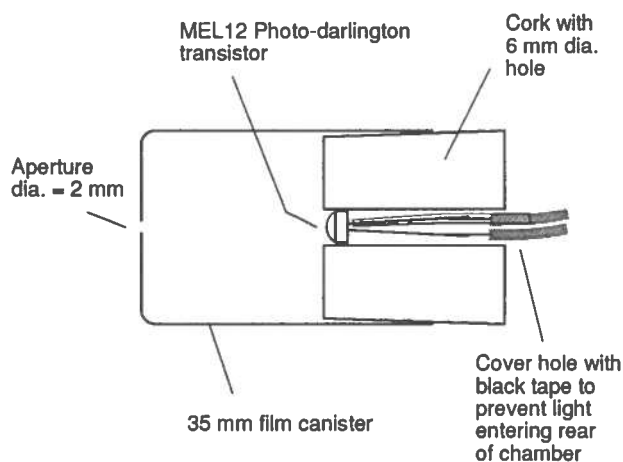

Figure 4 Minimise ambient lighting by enclosing sensor.

5 *Accuracy* : The rise time of 3.2 ms and fall time of 0.5 ms produce systematic uncertainties in event times. (Rise time is time taken from 10% to 90% of final voltage.) The operative uncertainties will be less than these values :

- Rise time delay from logic 0 to +2.8 V :	1.5 ms
- Fall time delay from logic 1 to +1.9 V :	0.3 ms

Another large source of uncertainty with light gates is parallax caused by the sizes of the light source and detector. To minimize this error :

(a) The sensor aperture should be small; preferably about 1 mm overall and certainly no larger than 2 mm.

(b) The source should be small and the radiation collimated to project on the detector. Suitable sources are lenticular lamps, or bright LEDs with a narrow beam angle.

(c) The mask should be as close to the detector as possible; generally the apparatus can be arranged to set this distance at about 1 cm.

6 *Component damage* : A diode may be connected in series with the 10 k Ω resistor and MEL12 to prevent the phototransistor being damaged by misconnecting a power supply. This lengthens the rise time from 3.2 ms to 3.8 ms.

7 *Test results* : The following data in units of m² are values of *g* made with this light gate (Fig. 3) in its housing (Fig. 4) with a lenticular bulb, 50 mm U-shaped mask and QED.

9.95	9.97	9.77	9.63	10.01
10.27	9.82	10.08	9.95	9.85

Mean value of <i>g</i>	= 9.93 m s ⁻²
Uncertainty (95%)	= ± 0.11 m s ⁻²

Summarizing the main points on this light gate, it seems to work moderately well, but its performance is less good than you get with some educational products such as 414.032 and 414.033 from Unilab.

Using a detector without a power supply is not recommended. By mounting the detector and source on a single frame, both can be operated from a single supply.

STOP PRESS :

IRWIN DESMAN IN RECEIVERSHIP

The manufacturer and supplier of educational apparatus, Irwin Desman, went into receivership on 20 April 1999.

The educational side of the business has been bought by Economatics. We understand that Economatics will review the product range, but intend to continue manufacturing and supplying products subject to this

review. Schools who have ordered goods from Irwin should contact Economatics about their order. Schools who would like to order Irwin products should also contact Economatics to find out whether items are available. They may also contact SSERC for information about substitute products.

We would like to acknowledge the service and co-operation shown to us by former Irwin employees and regret this misfortune which has befallen them.

Equipment Offers

Items are arranged by similarity of application, or for other reasons, and not by stock number sequence. Often the item number serves only for stock identification by us in making up orders. Newer stock items are underlined, so as to be more easily seen.

VAT : The prices quoted do not include VAT. However it is added to every customer's order. Local authority establishments will be able to reclaim this input VAT.

Postage : Postage and, where necessary, packing, will be charged for.

It is therefore best not to send cash with an order, but wait for us to bill you. Official orders may be used.

Please try and ask for at least £10 worth of goods because the administrative costs of handling orders are significant.

Don't send cash with orders

We repeat, please do not send payment with your order. Wait until you receive our advice note upon which payment may be made. This saves unnecessary complications, e.g. when items are out of stock, failure to make provision for VAT, or if a delivery charge needs to be made. Items of equivalent value may be deducted from your order to balance any shortfall.

Motors

- 778 Stepper motor, Philips MB11, been stored in damp conditions but unused and retested. 4 phase, 12 V d.c., 100 mA per coil, 120 Ω coil per phase, step angle 7.5°, with 7 mm x 2 mm dia. output shaft. Dimensions 21 mm x 46 mm dia. on oval mounting plate with 2 fixing holes, diam. 3 mm, pitch 42 mm, at 56 mm centres. Circuit diagram supplied. £2.50
- 755 Pulley wheel kit comprising:
- plastic pulley wheel, 30 mm dia., with deep V-notch to fit 4 mm dia. shaft,
- two M4 grub screws to secure pulley wheel,
- Allen key for grub screws, and
- 3 mm to 4 mm axle adaptor.
The whole making up a kit devised for SSERC tachogenerators with 3 mm shafts.
Specially supplied to SSERC by Unilab. £1.25
- 848 Motor, 12 V d.c., no load current 2 A at 12 V and 1.5 A at 5 V. Min. no load starting voltage, 2 V, min no load running voltage 0.8 V. 64 X 37 mm dia., shaft, 11 X 3 mm dia. £2.50
- 614 Miniature motor, 3 V to 6 V d.c., no load current 220 mA at 9600 r.p.m. and 3 V, stall torque 110 mNm, dims. 30 mm x 24 mm dia., shaft 10 mm x 2 mm dia. 45p
- 593 Miniature motor, 1.5 V to 3 V d.c., no load current 350 mA at 14800 r.p.m. and 3 V, stall torque 50 mNm, dims. 25 mm x 21 mm dia., shaft 8 mm x 2 mm dia. 30p
- 739 Miniature motor, 1.5 V d.c., dimensions 23 mm x 15 mm dia., shaft 8 mm x 1.7 mm dia. 25p
- 621 Miniature motor, 1.5 V to 3 V d.c., open construction, ideal for demonstration, dimensions 19 x 9 x 18 mm, eight tooth pinion on output shaft. 25p
- 839 Motor, solar, 12 mm long by 25 mm dia., shaft 6 x 2mm dia. (see also Item 838 - solar cell) £1.70
- 773 Tachometer (ex equipment) £2.25
- 811 Worm and gear for use with miniature motors, 34 : 1 reduction ratio plastic worm and gear wheel. 35p
- 378 Encoder disk, 15 slots, stainless steel, 30 mm dia. with 4 mm dia. fixing hole. 80p
- 642 Encoder disk, 30 slots, stainless steel, 30 mm dia. with 4 mm dia. fixing hole. 80p
- 772 Encoder disk, 4-bit Gray code, stainless steel, 81.28 mm dia., 3 mm fixing hole, slots sized to register with components mounted on 0.1" stripboard. Applications: shaft position sensing, wind direction indicator.
For related electronic circuitry see Bulletin 146. £3.00

Precision motor stock

- 785 Precision motor with optical shaft encoder, 0.25 to 24 V d.c., no load current and speed 9 mA and 6,600 r.p.m. at 24 V, stall torque 23 mNm, 9 segments. Overall body length including shaft encoder 59 mm, dia. 23 mm with output shaft 20 x 3 mm dia. Back EMF constant 3.6 V/1000 r.p.m. Suggested application - tachogenerator. Data on shaft encoder section available on application. £15
- 787 Precision motor with attached gearbox, 0.15 to 12 V d.c. With a supply of 3 V, the no load current is 25 mA and the output shaft turns at ca. 20 r.p.m. Gearbox ratio 1 : 365. Overall body length including gearbox 43.5 mm and diameter 16 mm. Output shaft 6 x 3 mm dia. with flat side to maximum depth of 0.3 mm along outer 5 mm length of shaft. Application - any system where a very slow angular velocity is required. £15
- 836 Motor mounts, plastic push-fit with self adhesive base pad, suitable for SSERC motors 593 & 614, pk of 10 £1.95

Miscellaneous items

- 801 Propeller, 3 blade, to fit 2 mm shaft, 62 long. 35p
(Replaces Item 791at lower cost).
- 792 Propeller kit with 10 hubs and 20 blades for making 2 or 3 bladed propellers. 130 mm diameter. Accepts either 2 mm or 3 mm shafts. £3.40
- 790 Buzzer, 3 V. 55p
- 827 Buzzer, 6 V. 55p

821	<u>Reducer, 3 mm to 2 mm</u> , enables gears, pulleys and wheels to be fitted to motor shaft, per 5	25p	809	Wire ended lamp, 3 V	10p
			741	LES lamp, 6 V.	15p
867	<u>Reducers, as above but 4mm to 2mm</u> , pack of 5	25p	770	LES lamp, but 12 V.	15p
868	<u>Ditto, 4 to 3mm</u>	25p	789	MES lamp, 3.5 V, 0.3 A	9p
			690	MES lamp, 6 V, 150 mA.	9p
846	<u>Sound module</u> , includes 'melody' chip and Piezo transducer.	£1.00	691	MES battenholder.	20p
710	Sonic switch and motor assembly. First sound starts the motor, a second reverses the direction of rotation, a third sound stops the motor. Driven by 4 AA cells (not supplied).	85p	692	Battery holder, C-type cell, holds 4 cells, PP3 outlet.	20p
715	Pressure gauge, ca. 40 mm o.d. case, 25 mm deep and 33 mm dia. dial reading 0 to 4 bar (i.e. above atmospheric). With rear fitting for 1/8" BSP. Suitable for use as indicator for pneumatic circuits in Technological Studies.	75p	730	Battery holder, AA-type cell, holds 4 cells, PP3 outlet.	20p
165	Bimetallic strip, original type length 10 cm; high expansivity metal: Ni/Cr/Fe - 22/3/75 low expansivity metal: Ni/Fe - 36/64 (invar)	15p	845	<u>Battery holder</u> , holds two C-type cells, PP3 outlet.	20p
166	Ditto, but 30 cm length.	40p	835	Battery holder, AA-type cell, holds 2 cells, PP3 outlet.	15p
861	<u>Bimetallic strip</u> (new type - won't rust after exposure to Bunsen flame hence higher price) 10 cm length.	30p	729	Battery connector, PP3 type, snap-on press-stud, also suitable for items 692 and 730.	5p
862	<u>Ditto, but 30 cm length.</u>	80p	724	Dual in line (DIL) sockets, 8 way.	5p
758	Loudspeaker, 8 Ω , 0.5 W, 66 mm dia.	50p	760	DIL sockets, 14 way.	7p
771	Neodymium magnet, 13.5 mm dia. x 3.5 mm thick.	£1.30	826	DIL sockets, 16 way.	8p
837	Ring magnet, 40 mm o.d., 22 mm i.d.	35p	808	Electrodes for making lemon or other fruit cells etc. 1 pair, comprising 1 of copper, 1 of zinc, each approx. 60 mm square, per pair	50p
815	Ceramic block magnets, random polarisation, 19 x 19 x 5 mm.	15p	716	3-core cable with heat resisting silicone rubber insulation, 0.75 mm ² conductors, can be used to re-wire soldering irons as per Safety Notes, Bulletin 166. Per metre.	£1.35
823	Ceramic block magnets, poles at ends, 10 x 6 x 22 mm.	12p	756	Silicone coated, braided glass sleeving, yellow, 2.5 mm dia., gives both heat and electrical insulation to conductors (e.g. for autoclave rewiring). Price per metre.	55p
824	Ceramic block magnets, poles on faces, 25 x 19 x 6 mm.	35p	714	Sign "Radioactive substance" to BS spec., 145 x 105 mm, semi-rigid plastic material. Suitable for labelling a radioactive materials store. With pictogram and legend.	£2.70
825	Forehead temperature measuring strips	50p	763	Sign "DANGER, Electric shock risk" to BS spec., rigid plastic, 200 x 150 mm.	£2.70
745	Sub-miniature microphone insert (ex James Bond?), dia. 9 mm, overall depth 5 mm, solder pad connections.	40p	764	Sign "DANGER, Laser hazard" to BS spec., rigid plastic, 200 x 150 mm.	£2.70
723	Microswitch, miniature, SPDT, lever operated.	40p	727	Hose clamp, clamping diameter from 8 mm to 90 mm, 101 uses - securing hose to metal pipe, tree to stake, joining wooden battens for blueing, etc.	30p
354	Reed switch, SPST, 46 mm long overall, fits RS reed operating coil Type 3.	10p	731	Re-usable cable ties, length 90 mm, width 2 mm, 50 per pack.	12p
847	<u>Rocker switches</u> , panel mounting, (mixed stock).	15p	752	Shandon chromatography solvent trough.	£1.00
738	Relay, 6 V coil, DPDT, contacts rated 3 A, 24 V d.c. or 110 V a.c.	75p	805	Condenser lens, bi-convex, 200 mm focal length, 75 mm dia. Crown glass.	£12.50
774	Solenoid, 12 V, stroke length 30 mm, spring not provided.	£2.25	806	Condenser lens, plano-convex, 150 mm focal length, 75 mm dia. Crown glass.	£12.50
742	Key switch, 8 pole changeover.	40p	833	5 1/4" double density floppy disks, box of 10	60p
382	Wafer switch, rotary, 6 pole, 8 way.	70p	834	5 1/4" high density floppy disks, box of 10	60p
688	Croc clip, miniature, insulated, red.	5p	Components - resistors		
759	Ditto, black.	5p	420	resistors, 5% tolerance, 1/4 W : Per 10. 1R5, 4R7, 5R6, 6R8, 8R2, 10R, 15R, 22R, 33R, 47R, 56R, 68R, 82R, 100R, 120R, 150R, 180R, 220R, 270R, 330R, 390R, 470R, 560R, 680R, 820R, 1K0, 1K2, 1K5, 1K8, 2K2, 2K7, 3K3, 3K9, 4K7, 5K6, 6K8, 8K2, 10K, 12K, 15K, 18K, 22K, 27K, 33K, 39K, 47K, 56K, 68K, 82K, 100K, 150K, 220K, 330K, 390K, 470K, 680K, 1M0, 1M5, 2M2, 4M7, 10M.	6p
788	Crocodile clip leads, assorted colours, insulated croc. clip at each end, 360 mm long.	£1.35			

421 DIL resistor networks, following values available:
62R, 1K0, 6K8, 10K, 20K, 150K. Per 10. 30p

BP100 Precision Helipot, Beckman, mainly 10 turn. 10p-50p

Components - capacitors

813 Capacitors, polystyrene: 4p
180 pF, 220 pF, 330 pF, 560 pF, 1000 pF, 2400 pF,
3000 pF, 3300 pF, 3900 pF & 4700 pF

695 Capacitors, tantalum, 1p
15 µF 10 V, 47 µF 6.3 V.

696 Capacitors, polycarbonate, 2p
10 nF, 220 nF, 1 µF, 2.2 µF.

697 Capacitor, polyester, 15 nF 63 V. 1p

698 Capacitors, electrolytic, 1p
1 µF 25 V, 2.2 µF 63 V, 10 µF 35 V.

358 Capacitor, electrolytic, 28 µF, 400 V. £1.00

Components - semiconductors

807a Schools' Chip Set, designed by Edinburgh University,
The 4 chip set comprises : Resistors; MOSFETS;
Diodes and Optoelectronics, and Ring Oscillator. £10.00

807b Individual chips, each : £4.00

322 Germanium diodes 8p

701 Transistor, BC184, NPN Si, low power. 4p

702 Transistor, BC214, PNP Si, low power. 4p

717 Triac, Z0105DT, 0.8 A, low power. 5p

725 MC74HC139N dual 2 to 4 line decoders/multiplexers 5p

699 MC14015BCP dual 4-stage shift register. 5p

711 Voltage regulator, 6.2 V, 100 mA, pre-cut leads. 10p

Sensors

615 Thermocouple wire, Type K, 0.5 mm dia., 1 m of each
type supplied: Chromel (Ni Cr) and Alumel (Ni Al);
for making thermocouples, see Bulletins 158 and 165. £2.20

640 Disk thermistor, (substitute type) resistance of 15 kΩ
at 25°C, β = 4200 K. Means of accurate usage described in
Bulletin 162. 30p

641 Precision R-T curve matched thermistor,
resistance of 3000 Ω at 25°C, tolerance ±0.2°C,
R-T characteristics supplied. Means of accurate
usage described in Bulletin 162. £3.00

718 Pyroelectric infrared sensor, single element, Philips
RPY101, spectral response 6.5 µm to >14 µm,
recommended blanking frequency range of 0.1 Hz to
20 Hz. The sensor is sealed in a low profile TO39 can
with a window optically coated to filter out wavelengths
below 6.5 µm. Data sheet supplied. For application see
SG Physics Technical Guide, Vol.2, pp 34-5. 50p

503 Kynar film, unscreened, 28 µm thick, surface area
12 x 30 mm, no connecting leads. £1.00

504 Copper foil with conductive adhesive backing, makes
pads for unscreened Kynar film to which connecting
leads may be soldered. Priced per inch. 15p

506 Resistor, 1 gighm, ¼ W. £1.40
Optical and opto-electronic devices

838 Solar cell, 100 x 60 mm, 3.75 V per cell max. £2.10

507 Optical fibre, plastic, single strand, 1 mm dia.
Applications described in Bulletin 140 and SG
Physics Technical Guide Vol.1. Priced per metre. 50p

508 LEDs, 3 mm, red. Price per 10. 50p

761 Ditto, yellow. Per 10. 60p

762 Ditto, green. Per 10. 60p

858 Flash bulb older type (getting difficult to source) for
UV triggered reactions in chemistry. Pack of 5. 85p

New - economy variable volume micropipettors

Of slimline profile, these micropipettors are fully autoclavable
(121° C max.). They have a nominal accuracy of ± 1.75%.
Supplied with spare O-ring and lubricant. Tip ejector swivels,
thus pipettors are suitable for either left- or right handed users.
Colour coded bodies for ease of identification. Supplied with
two tips and stocks of spare tips available. Three sizes :

849 micropipettor, 1 cm³, range 100 to 1000 µl £16.00

850 micropipettor, 5 cm³, range 500 to 5000 µl £16.00

851 micropipettor, 10 cm³, range 1000 to 10,000 µl £16.00

Replacement tips in packs of 25 tips :

852 replacement tips for 1 cm³ micropipettor, pack. £1.50

853 replacement tips for 5 cm³ micropipettor, pack. £1.70

854 replacement tips for 10 cm³ micropipettor, pack. £2.15

Other biotechnology related items for Higher Practicals:

859 Eppendorf tubes, 1.5 cm³, for use in TEP/SAPS/NCBE
microcentrifuge, pack of 50 85p

860 Nylon mesh for protoplast isolation/fusion protocol,
70µm pore size, per 305 mm square. £7-00

Pipette fillers

863 0-2 cm³ pipette filler (Pi pump type), each £5.75

864 0-10 cm³ as above £5.75

865 0-25 cm³ as above £5.75

Items not for posting

The following items are only available to callers because of our
difficulties in packing and posting glass items and chemicals. We
will of course hold items for a reasonable period of time to enable
you to arrange an uplift.

768 Sodium lamp, low pressure, 35 W. Notes on method
of control available on application. 85p

810 Watch glasses, assorted sizes 20p

712 Smoke pellets. For testing local exhaust ventilation (LEV) -
fume cupboards and extractor fans : large, 50p, small, 40p

* * *

SSERC, St Mary's Land, 23 Holyrood Road, Edinburgh,
EH8 8AE. Tel: 0131 558 8180, Fax: 0131 558 8191,
Email: sserc@mhie.ac.uk. Website: [http://www.svtc.org.uk/
resources/sserc/](http://www.svtc.org.uk/resources/sserc/)

ASE (UK, HQ), College Lane, Hatfield, Herts., AL10 9AA.
Tel: 01707 267411, Fax: 01707 266532. Website : [http://
www.ase.org.uk](http://www.ase.org.uk)

ASE Scotland, Dr Susan Burr, (Secretary), Newbarns, 18
Holding, Mainholm, Ayr KA6 5HE. Website : [http://
www.asescotland.org.uk/](http://www.asescotland.org.uk/)

A.&J. Beveridge, 5 Bonnington Road Lane, Edinburgh EH6 5BP
Tel. 0131 553 5555.

Didier POL, Professeur de sciences de la vie et de la Terre,
formateur. Lycée H. Wallon 146, rue des Cités - 93300 -
Aubervilliers, FRANCE.
Website: <http://www.users.imaginet.fr/~pol/>

Economatics (Education) Limited, Epic House, Darnall Road,
Attercliffe, Sheffield, S9 5AA. Tel: 0114 281 3260,
Fax: 0114 243 9306.

Farnell Electronic Components, Canal Road, Leeds, LS12 2TU.
Tel: 0113 263 6311, Fax: 0113 263 3411.

Griffin & George, Bishop Meadow Road, Loughborough,
Leicestershire, LE11 5RG. Tel: 01509 233344,
Fax: 01509 231893, Email: griffin@fisher.co.uk

Philip Harris Education:
2 North Avenue, Clydebank Business Park, Clydebank,
Glasgow, G51 2DR. Tel: 0141 952 9538.
Lynn Lane, Shenstone, Lichfield, Staffordshire, WS14 0EE.
Tel: 01543 480077, Fax: 01543 480068.

HSE Books, PO Box 1999, Sudbury, Suffolk, CO10 6FS.
Tel: 01787 881165, Fax: 01787 313995.

Hi-Tech UK, Purex House, Farfield Park, Manvers, Rotherham,
South Yorkshire, S63 7DB. Tel: 01709 763000,
Fax: 01709 763001, E-mail: purex@dial.pipex.com

JJM Electronics, The Hedges, Meft Road, Urquhart, Morayshire,
IV30 3LG.

Maplin Electronics, FREEPOST SMU 94, PO Box 777,
Rayleigh, Essex, SS6 8LU. Tel: 01702 554000,
Fax: 01702 554001.

Multicore Solders Limited, Kelsey House, Woods Lane End,
Hemel Hempstead, Hertfordshire, HP2 4RQ.
Tel: 01442 233233, Fax: 01442 269554.

National Radiological Protection Centre (NRPB), Chilton,
Didcot, Oxfordshire, OX11 0RQ. Tel: 01235 831600,
Fax: 01235 833891, E-mail: nrbp@nrbp.org.uk

National Centre for Biotechnology Education (NCBE), The
University of Reading, Whiteknights, PO Box 228, Reading
RG6 6AJ Tel: 0118 987 3743, Fax: 0118 975 0140. Email :
NCBE@reading.ac.uk. Website: [http://www.reading.ac.uk/
NCBE](http://www.reading.ac.uk/NCBE)

PASCO Scientific: UK distributor:
Instruments Direct Limited, Unit 4, Brentford Business Centre,
Commerce Road, Brentford, TW8 8LG. Tel: 0181 560 5678,
Fax: 0181 232 8669.

RS Components, PO Box 99, Corby, Northants., NN17 9RS.
Tel: 01536 201201, Fax: 01536 201501.

Rapid Electronics Limited, Heckworth Close, Colchester, Essex,
CO4 4TB. Tel: 01206 751166, Fax: 01206 751188.
Email: sales@rapidelec.co.uk

Royal Society of Edinburgh, 22-26 George Street, Edinburgh,
EH22 2PQ. Tel. 0131 240 5000 Fax 0131 240 5024 (Education
Officer, Alice Hague). Website : <http://www.ma.hw.ac.uk/RSE>

Scottish Council for Research in Education (SCRE), 15 St John
Street, Edinburgh; EH8 8JR. Tel. 0131 557 294, Fax 0131 556
9454. Website : <http://www.scre.ac.uk>

Scottish SETPOINTS :

Dr Liz Robertson SETPOINT North Scotland, University of
Aberdeen, Marischal College, Broad Street, Aberdeen, AB9
1AS Tel: 01224 273161 Fax: 01224 273160 E-mail:
info@abdn.setpoint.org.uk
Website: <http://www.abdn.setpoint.org.uk>

Sylvia Cowan, SETPOINT West Scotland, Glasgow EBP,
Partners in Learning Centre, The Adelphi, 12 Commercial
Road, Glasgow G5 0PQ Tel: 0141 429 1999 Fax: 0141 429
8797 Email: info@gebp.co.uk Website: [www.bigfoot.com/
~setpoint_ws](http://www.bigfoot.com/~setpoint_ws)

George Maxwell SETPOINT East Scotland, Lothian EBP,
Atholl House, 2 Canning Street, Edinburgh, EH3 8EG Tel:
0131 228 7537/8 Fax: 0131 228 3146;
Email: George@lothianeyp.demon.co.uk
(Website : under construction).

Technology Teachers' Association : Lorna Nicholson,
(Secretary), 3 Conifer Place, Lenzie, Nr Glasgow G66 4EJ.

Wagh Instruments Limited, Camhelyg Isaf, Glyn Ceiriog,
Llangollen, Clwyd, LL20 7PB. Tel: 01691 718597.

R.&J. Woods, 39 Back Sneddon Street, Paisley, PA3 2DE
Tel. 0141 887 3531.



ASE Technician Member receives training in first line fire fighting from Grampian Fire Brigade Staff, ASE Scotland Annual Meeting, Aberdeen, March 1999