

The hidden radiations: ultraviolet and infrared

	Experiment title	Purpose	Page
1	UVR: Fluorescence	To look at the phenomenon of fluorescence.	10
2	UVR: Fluorescence and Phosphorescence	To look at the phenomenon of fluorescence and distinguish between it and phosphorescence.	11
3	UVR: Reflection and refraction	To show that ultraviolet radiation can be reflected and refracted.	13
4	UVR: Optical displacement	To shift a UV beam sideways by passing through a rectangular water tank, which is then rotated.	15
5	UVR: Critical angle of water	To show total internal reflection and measure the critical angle of water.	17
6	UVR: Diffraction and interference	To produce interference fringes with UVR and a diffraction grating; to determine the wavelength of the radiation.	20
7	UVR/Visible/IRR: Diffraction, interference and wavelength	To produce sets of interference fringes with ultraviolet, visible and infrared radiations.	21
8	UVR/Visible: A spectrum with an invisible component beyond violet	To produce a spectrum which includes both UVR and visible components from a hot filament source.	23
9	UVR: To discharge an electroscope by photoemission	To show the photoelectric effect by irradiating a zinc plate on a charged electroscope with ultraviolet radiation from LED sources. The discharge when the charge on the charged plate is negative is evidence of photoemission. The threshold for photoemission is found from the highest waveband seen to cause it.	25
10	UVR/Visible: Neon lamp induced to strike by photoemission	If light is shone on a neon lamp energized at a few volts below its striking voltage the lamp can be caused to strike. The effect is frequency dependent. It can be inferred that the radiation causes electrons to be ejected by photoemission from the electrodes on the neon.	27
11	UVR/Visible: Millikan's photoelectric experiment and Planck's constant	To show that the stopping voltage of photoelectrons from a photoemissive cell has a linear dependence on the frequency of radiation and to derive a value for Planck's constant.	30
12	IRR: Herschel's experiment on discovery of infrared radiation	To disperse white light from a hot-filament lamp and show with thermometers that the spectrum extends beyond its visible bounds into infrared.	33
13	IRR: A spectrum with an invisible component beneath red	To disperse white light from a hot-filament lamp and show, with a webcam, that there is an invisible component beneath red.	35
14	IRR: Refraction and reflection of infrared radiation	To show that infrared radiation can be refracted, either by collimating or focusing with a lens; also to show that infrared radiation can be reflected off a mirror.	37
15	IRR: Diffraction and interference of infrared radiation	To show that infrared radiation can be diffracted with a transmission grating, which results in interference fringes; to determine the wavelength.	39
16	IRR: Reflection of infrared radiation	To transmit infrared radiation across the lab with a pair of parabolic reflectors.	41
17	IRR: Visible indicator of infrared radiation	To give a visual indication of infrared radiation from its suppression of phosphorescence.	44
18	IRR: Wavelength sensitivity of a silicon photodiode	To compare the efficacy of photodiodes with wavelength of radiation.	45
19	IRR: Photodiode area	To compare the dependence of the photocurrent on photodiode area.	47
20	IRR: Linearity of photodiode's response	To check on the linearity of a photodiode's response to infrared radiation.	48
21	IRR: Inverse-square law	To show that the dependence of intensity with distance is an inverse-square relationship with infrared radiation.	50

	Experiment title	Purpose	Page
22	IRR: To transmit chopped IRR across the lab with lenses	To transmit chopped infrared radiation across the lab with lenses.	52
23	IRR: Infrared remote controller	To pick up the emissions from an infrared remote controller with a webcam, display the signals on a storage oscilloscope and analyse the signals.	55
24	IRR: Thermopile	To investigate the thermopile, finding out how it works and what its use is.	56
25	Inverse-square law with heat radiation	To show that the dependence of intensity with distance is an inverse-square relationship with infrared heat radiation.	58
26	IRR: Non-contact temperature sensor	To use a non-contact temperature sensor.	59
27	IRR: Radiant efficiency of lamp	To measure the radiant efficiency of a tungsten filament lamp.	60
28	IRR: Heat absorption by black or silver surface	To compare the absorptivity of black and silver surfaces.	61
29	IRR: Focusing heat radiation	To find if heat radiation can be focused with a flask of water, or a lens, thus charring or igniting paper.	63
30	IRR: The seasons	To show the differences in seasonal heating of the Earth because of the tilt in its spin axis.	64
	Introduction		3
	Sources and detectors		4
	Optical materials		4
	Educational purpose		5
	Historical review		6
	Health and Safety		
	Optical, UV and IR hazards	Summary	66
	Optical sources	Control measures and safety guidance	67

Introduction

The scope of the Guide includes laboratory experiments for secondary science education on infrared and ultraviolet radiations. Because these invisible radiations are often accompanied with visible radiation some experiments bring in visible optical radiation, but only insofar as needed to show up properties of one or other of the hidden radiations.

Infrared, visible and ultraviolet radiations are all types of 'optical radiation'. Both infrared and ultraviolet are classified into three sub-groups each (see Table below). The sources and detectors referred to in the Guide are listed for each radiation type.

Radiation Type	Short name	Waveband	Sources	Detectors
Ultraviolet C	UVC	100–280 nm	Low-pressure mercury lamp (quartz glass) UVC LED	Photoemission from zinc
Ultraviolet B	UVB	280-315 nm	Tungsten-halide lamp Low-pressure mercury lamp UVB LED	Fluorescent materials Phosphorescent materials UV beads
Ultraviolet A	UVA	315-400 nm	Tungsten-halide lamp Low-pressure mercury lamp UVA LED	Fluorescent materials Phosphorescent materials UV beads Photodiode (Si) Phototube Thermopile
Visible		400-700 nm	Tungsten-halide lamp Tungsten-filament lamp Visible LED	Photodiode (Si) Phototube Thermopile
Infrared A	IRA	700-1400 nm	Tungsten-halide lamp Tungsten-filament lamp Quartz Heat Lamp IRA LED Infrared remote controller Hot-wire filament	Photodiode (Si) Webcam (modified) Thermopile Black-bulb thermometer Zinc-sulphide phosphorescence
Infrared B	IRB	1400-3000 nm	Tungsten-halide lamp Tungsten-filament lamp Quartz Heat Lamp Hot-wire filament	Thermopile Infrared thermometer Black-bulb thermometer
Infrared C	IRC	3 μm – 1 mm	Tungsten-halide lamp Tungsten-filament lamp Quartz Heat Lamp Hot-wire filament	Thermopile Infrared thermometer Black-bulb thermometer Photochromic materials Heat Sensitive Paper

Sources and detectors

The source in many of the ultraviolet experiments is a 370 nm LED. This is a narrow-band emitter (from 350 to 390 nm) of UVA only. You would have to make this circuit (with LED) yourself, but it is a simple soldering job, there being no off-the-shelf product. Generally the beam of UV radiation is detected from the fluorescence on ordinary photocopier paper. When constructing a LED circuit, think about how you are going to support the LED circuit ensuring that the LED's height matches that of lenses and mirrors in their holders. Our LED circuits were supported on wooden blocks with grooves. This is shown in illustrations for Experiments 3, 4 and 5.

The source for many of the infrared experiments is similarly a LED, one with a bandwidth from 880 nm to 1050 nm. Unlike UV, where detection is visual, by fluorescence, there is no easy means of detecting near-infrared radiation without resorting to electronics. We make use of photodiodes, phototransistors and a modified webcam. In all of these devices, the detecting agent is a p-n junction in doped silicon. It would be necessary to construct your own circuits with IR LEDs and photodiodes. Again ensure that the component heights match – and with your optical elements. Examples of our constructions can be found illustrated in Experiments 14, 15, 16, 22 and 23.

When working beyond the near-infrared (above 1.1 μm), doped silicon does not operate and other detectors should be used. Types of semiconductors that operate in parts of IRA and IRB include germanium (700 nm – 1.8 μm), indium gallium (arsenide) (700 nm – 1.8 μm) and lead sulphide (1 – 3.5 μm), but none of them were used in our work. We did however use heat-detecting devices such as the thermopile, black-bulb thermometer, and photochromic and other materials. A thermopile is an array of thermocouple junctions fixed alternately to an irradiated surface and a shaded mass thermalized with the surroundings. Both it and a black-bulb thermometer have flat spectral responses from UV across visible to the far IR.

Optical materials

Standard glass types transmit across the entire visible spectrum and beyond in the near-ultraviolet and near-infrared regions. Crown glasses can transmit down to 300 nm or below. Flint glasses tend not to transmit as deeply into the near-UV. Transmission stops somewhere between 300 nm and 370 nm, dependent on glass type. Quartz (or UV-grade fused silica) transmits across the UV spectrum to below 200 nm. At the other end of the spectrum, standard glass types transmit near-infrared up to about 2.4 μm , absorb to 3 μm , transmit quite well to 4 μm , but thereafter do not transmit. In practice we find that ordinary crown-glass lenses and prisms transmit the entire optical spectrum from about 300 nm to 2400 nm. This includes all of UVA and IRA, and some of UVB and IRB. Flint glass transmits from some cut-off between 300 nm and 370 nm (dependent on the type of glass) to 2400 nm, then with interruptions to 4 μm .

Polarizing film of the sort used with visible radiation cannot be used with ultraviolet or infrared. It stops transmitting at wavelengths below 400 nm and does not operate in the near-infrared region. Polarizers that do work in the UV or IR regions are considered to be too expensive for school users.

Longpass and shortpass filters are made use of in some of our experiments. A longpass filter passes wavelengths longer than the wavelength range that is blocked. In some of the experiments UV longpass filters are used in blocking UV radiation. In others, IR shortpass filters are used to transmit visible radiation and block infrared. One type of IR shortpass filter is called a *hot mirror*. It transmits visible light and reflects infrared. Another type is called

heat-absorbing glass. It transmits visible light but absorbs infrared. We also use a near-IR bandpass filter. This blocks visible light and transmits near-infrared.

Experiments on the inverse-square law, linearity of response and dependence on detector surface area rely on the radiation being uniform. This is achieved by transmitting the radiation through a light-shaping diffuser (LSD). Although designed for visible radiation, they work for near infrared too.

Educational purpose of the Experimental Guide

Reviewing some of the existing reasons for conducting experiments with ultraviolet or infrared radiation, the list is:

- "Because it's there".
- Extending the electromagnetic spectrum from the visible part to the invisible regions.
- Applications in Health Physics.
- Applications in Telecommunications (near-infrared).
- Radiant heat, being one of the three forms of heat transport.
- Photoelectric effect.
- Advanced Higher investigations.

All of these reasons are supported by this set of experiments, but with the coming of new courses there is scope for much more practical work. Some of this will be done as whole-class experiments. Some will be teacher-demonstrations. Others will be investigations by pupils, either individually, in pairs or small groups.

In preparing these experiments, I have noted how many of them have parallels with visible optics. Some of the experiments are just invisible versions of what you might do with light. These experiments can be regarded as extensions of standard optics. I think that many pupils will relish the challenge of working with invisible rays.

Many experiments are certainly harder to do in that the radiation is invisible. Ranking the order of difficulty, as a general rule, visible optics is the easiest. Next comes ultraviolet. It is ranked second easiest because the position of the radiation can often be found by its fluorescing effect on paper. Hardest of all is infrared. There is no simple way of sensing it unless there is an obvious heating effect. If the IR wavelength lies between 700 and 1100 nm, it can be detected opto-electronically with doped silicon detectors such as photodiodes, or a webcam. If the wavelength is longer than 1100 nm, other detecting methods should be used, either with exotic materials, or devices that sense heat.

Some of the experiments bring in new effects. Others reinforce old concepts, giving you a means of recycling concepts like reflection, refraction, diffraction and interference; transmission and absorption; intensity, irradiance and the inverse-square law; and frequency modulation.

The photoelectric effect experiments have new and interesting details.

In summary there is much that can be done when you enter into the hidden world of the invisible radiations.

Historical account of discoveries

Here is a short history of the scientific discoveries of infrared and ultraviolet radiation. We also describe some of the key findings that preceded and followed on from the discoveries, leading to our present understanding of optical radiation.

By knowing the historical development of concepts and the philosophical thinking that led up to and stemmed from them, this may help you, the teacher, come to a better understanding of optical radiation. Physics has within it many strands of thought. The subject tends to be taught in little chunks, a little bit at a time. Because of that, very often, neither the teacher nor student can see the wood for the trees. The big questions get missed. The interconnections between disparate topics go unnoticed. Our potted history brings to your attention some of the very famous physicists of times past. It presents you with the questions they asked, the problems they faced and the answers they found.

The story begins with heat radiation. We may nowadays believe that heat radiation is self-evident. On a sunny day we can feel the sun's heat on our body. On a winter's night we feel the heat radiated towards us from the fire. However the concept of *radiant heat* took time to emerge.

The story of radiant heat began when that phenomenon began to be noticed by early philosophers and scientists. Ultraviolet was then beyond everyone's ken. Plato (around 400 BC) understood heat to be due to the movement of the constituent small parts of matter. The first modern to see heat in this way was Francis Bacon (1561-1626), who wrote that "heat itself, its essence and quiddity, is motion and nothing else".

Around 1679 Mariotte (he, who independently of Boyle, discovered the pressure-volume law of a gas) showed that heat rays could be focused and, like light, could be transmitted through a vacuum. He showed that dark colours absorbed heat more readily. Also he found that the heat and light from a fire could be separated by glass for glass transmits the one but not the other.

Newton expressed his ideas on what was then known as the undulatory theory in which he linked radiant heat with light in a series of questions in his book 'Opticks' (1704). Note however that the concept of *radiant heat* was yet to thought of.

"Do not all fixed bodies, when heated beyond a certain degree, emit light and shine, and is there not this emission performed by the vibrating motion of their parts?"

"Do not several sorts of rays make vibrations of several bignesses?"

"Is not the heat conveyed by the vibrations of a much subtler medium than air?"

Interrupting our story of radiant heat, but germane to the bigger picture of optical radiation, Newton had discovered through a series of brilliant experiments with prisms (1672) that white light was a composite of colours (the colours of the solar spectrum). He invented the word *spectrum*. The sun's spectrum consists of seven colours from red at one end to violet at the other.

Returning to radiant heat, the next significant development came when a Swedish apothecary and chemist, Carl Wilhelm Scheele (1742-86), discovered that there are two kinds of heat, which he called *radiant heat* and *familiar heat*. By the latter we know of as the internal heat of a substance caused by the continuous movement of molecules. Scheele compared and distinguished radiant heat with light. Light was reflected from a polished metal surface and refracted by glass. Radiant heat was reflected by the metal but absorbed by the glass. Whereas a very hot source emits both radiant heat and light, a cooler source emits only radiant heat. He showed this by placing a non-luminous heat source (being a flask of boiling water) at the focus of a parabolic metal reflector and detecting heat at the focus of a second parabolic reflector facing the first.

On considering the experimental results of Scheele, Cavendish (1731-1810) became convinced of the similarities between radiant heat and light. He envisaged radiant heat to be rays of 'heat-particles' by analogy with Newton's rays of 'light corpuscles'. This agrees in part with the present interpretation. However Cavendish didn't publish his views.

Thomas Young (1773-1829), the polymath and brilliant scientist, was one of the first to suggest that radiant heat and light were really two of the same thing. Having shown by experiment that light was an undulatory (or wave) motion, he inferred that heat, too, was, deducing that the different colours of light were part of a spectrum in which the frequency of vibration determines colour. Heat radiation was predicted to happen with vibrations with lower frequencies than the red end of the visible spectrum. Young also predicted there would be an invisible high-frequency radiation beyond the violet end of the spectrum. These predictions were made in 1801, almost at the same time as William and Caroline Herschel were discovering infrared radiation.

This famous discovery by the Herschels took place in 1800. William Herschel was a German-born British astronomer. Working with his sister Caroline, William was observing the sun through a telescope. As looking at the sun directly is hazardous, the two of them fitted dark glass filters to reduce the light's intensity. Finding that some colours were transmitted better than others, and finding that heat was also transmitted, they set about investigating the heating effects of the different colours in the spectrum. Using three thermometers with blackened bulbs, they placed one in the visible spectrum of the sun created by refraction through a prism and the other two outside the spectrum as controls. By moving the middle thermometer from colour to colour, they found that the temperature in sunlight was higher than in the shade and varied from colour to colour, getting hotter as it was moved from violet to red. After one sequence of readings, as the sun moved across the sky the spectrum moved off the middle thermometer to the outside of the visible red. They were amazed to find that it also recorded a higher temperature than the controls, indeed higher than anywhere in the visible spectrum. Dubbing them 'calorific rays', the Herschels showed that their rays could be reflected, refracted, absorbed and transmitted as if they had been visible light.

Later the terms *heat radiation* or *calorific rays* became known as *infrared radiation*.

Hearing of the Herschels' discovery, the young German scientist, Johann Wilhelm Ritter (1776-1810), guessed that there should also be an invisible, cooling radiation beyond the violet end of the visible solar spectrum. Knowing that silver chloride blackened when exposed to light, and in particular to light at the blue end of the spectrum, he used this as his method of detection, finding that it blackened beyond the violet edge. The year of discovery of ultraviolet was 1801. So Ritter had found the invisible radiation he was after, but whether he found it to have a cooling effect, I don't know, but would think not.

Whereas infrared radiation was found unexpectedly by two clever scientists guddling about with equipment, ultraviolet was discovered because Ritter looked for it. Both he and Thomas Young had predicted there might be an invisible radiation lying beyond violet.

Having found that optical radiation has invisible parts bounding the visible, the story moves from discovery to understanding. One key was the formulation of the concept of *energy*. There were many players in the discovery of energy. Energy has, with good cause, been dubbed 'the subtle concept'. It eluded all from Galileo onwards until Clausius formulated the two laws of thermodynamics (1850) and Thomson introduced the terms *thermodynamics* and *energy* (1851). It was from this time in physics that energy was seen as "the important concept, superseding force, mass, and even atoms".

Maxwell's electromagnetic theory (around 1870) envisaged the transport of energy by an oscillatory field travelling as a transverse wave at the velocity of light. At this time the known

electromagnetic spectrum comprised just the three forms of optical radiation: ultraviolet, visible and infrared.

We need to bring atoms and molecules into the story. It had long been conjectured that matter is composed of an enormous number of invisibly small parts. The property we call heat is a manifestation of the chaotic movement or jostling of these tiny parts. In his kinetic theory of gases (1867) Maxwell devised a new statistical mechanics to handle a distribution of molecular speeds. Boltzmann built on the kinetic theory (around 1877), in particular on Maxwell's use of probability. This work had an important bearing on the way Planck analysed the black-body radiation problem.

In the latter stages of the nineteenth century, from spectroscopic evidence, it was found that each element and molecule had its own unique set of emission and absorption lines. This linked the frequencies of the undulatory waves of Young and Maxwell with oscillations within the particulate stuff of matter. Atoms had been postulated by Dalton at the century's beginning, but were still hypothetical entities until the experimental evidence became persuasive. It was Einstein's theory on Brownian motion (1905) followed by experimental confirmation by Perrin that convinced the sceptics that matter is atomistic.

Aside from the line-emission spectra, which can be thought of as the signature tunes of atoms, the broad-band spectra from a new class of optical sources – electric lamps – revealed a puzzle. This so-called *black-body radiation* could not be explained with what we now call *classical physics*. Trying to understand the problem, Max Planck (1900), knowing that Boltzmann, his academic teacher, had earlier postulated that the energy distribution of a gas was quantized, adopted the radical idea that the energy of radiation comes in discrete chunks, or quanta. From his new theory, radiation energy is given by

$$E = h\nu$$

where ν is the frequency of radiation and h is a constant, now known as Planck's constant.

The photoelectric effect was an incidental discovery by Hertz. Noticing that an electric spark would jump more readily across the air gap between the metal spheres of his receiving circuit if they were well polished, it was soon found that ultraviolet radiation (as from the spark of the transmitter) incident on the clean surface of a metal had the effect of expelling negative charge and it was this effect that helped maintain the current between Hertz's spheres.

The original experiments on the photoelectric effect were largely down to Philipp Lenard (1902). His findings led Einstein (1905) to postulate that radiation is quantized (compare Planck's black-body interpretation that energy is quantized), with the energy of a 'light particle' (soon to be called the *photon*) being $h\nu$. The theory was confirmed by experiment by Millikan (1916). Following shortly on, using Planck's idea of energy quantization and Einstein's radiation quantization, Bohr developed his atomic theory. This explained the transfer of energy in and out of an atom by optical radiation in the form of line spectra.

Overview

This is where we end our story. To summarize where we now are, optical radiation can be thought of as a transfer of energy by a transverse electromagnetic wave, or by a photon of energy $h\nu$. We now think of the photon as having a wave train about a metre long travelling at c through space. When light is absorbed by an atom, a photon is annihilated, raising the potential energy of the atom. We say that the atom is raised to an *excited* state. When the atom in its excited state loses its potential energy, it does so by the emission of a photon. The energy levels of atoms are quantized. The radiated energy is of the form of a *line emission spectrum*.

The photons of ultraviolet radiation have a higher energy than ones of infrared radiation. The absorption by an atom of a high-energy photon (whether in radiation of the type called ultraviolet, x-ray, or gamma) can result in ionisation. The atom loses an electron (called a *photoelectron*) in a process called *photoemission*, or the *photoelectric effect*. The kinetic energy of the photoelectron is $h\nu - W_0$ where W_0 is the work function of the material under irradiation.

Radiant heat can be modelled either as a collection of particles (photons) or as electromagnetic radiation. With a black-body radiation source at thermal equilibrium, the radiation has a characteristic distribution of wavelengths. The peak wavelength (the colour) is inversely proportional to the temperature (Wien's law). There is a mixture of radiation and matter, or light and electrons. When the mix is in equilibrium, electrons jostle around, collide and change direction. When an electron accelerates, as many of them do continually, electromagnetic radiation is generated. With so many hot electrons in a typical radiant source, say a lamp filament, the rate of production of photons is very great. This soup of photons and hot electrons maintains itself in equilibrium, radiating energy as the famous black-body radiation spectrum. For tungsten-halide lamps at standard brightness, the spectrum stretches from ultraviolet into the far-infrared – all three forms of optical radiation – one of them visible and the other two hidden from sight.

Acknowledgement

This historical review has been drawn from many sources. The main source is Jennifer Coopersmith's book 'Energy, the subtle concept', published by Oxford in 2010.

If you wish to get further into the history of the hidden optical radiations, there are many key words and names in the text to help you search for more information on the internet, or in books.

UVR: Fluorescence

Purpose: To look at the phenomenon of fluorescence.

Information: Fluorescence is light given out by a substance when it is exposed to radiation, particularly ultraviolet light or X-rays – but the effect can also happen when the incident radiation is visible. It is the property of giving out light in this way. The fluorescent radiation has a longer wavelength than that which irradiated the surface and occurs without delay.

Fluorescence is one of the standard ways of detecting ultraviolet radiation because the emission is visible. In this sense it shows the presence of ultraviolet or X-rays.

In this experiment and in most of the following ones with ultraviolet radiation the main UV source is a 370 nm UV LED, which, as a confounder, emits a little visible violet. The experimenter has to distinguish between the diffuse reflections of violet radiation and emissions of fluorescence from the irradiated surface.

What you need: Photocopier paper, Filter paper, Fluorescent Plate, UV LED, Red-Green-Blue LED set, UV filter, 5 V supply.

What to do:

1. The UV source is a 370 nm UV LED also emits a little visible violet. You, the experimenter, have to distinguish between the diffuse reflections of violet radiation and emissions of fluorescence. Shine the UV LED at both the photocopier and filter paper. Which of the two fluoresces?
2. Irradiate the Fluorescent Plate with, one by one, light from the UV, blue, green and red LEDs. Which radiations cause the Plate to fluoresce?
3. Direct each of the radiations at the UV filter. Is the filter longpass or shortpass and what is meant by these terms? What, roughly, is the cut-off wavelength of the filter?

Equipment:

The Fluorescent Plate is a product from Frederiksen (3076.00). A similar product (half fluorescent, half non-fluorescent) can be bought from Leybold Didactic (469 42).

The UV filter is a product from Edmund Optics (UV Filter Sheet) (NT39-426) (£9.46). The sheet measures 20" x 24". We have cut it up and mounted pieces in 35 mm slide mounts.

UV LED: 370 nm, Marl 260018, Farnell part number 105-7079. Series resistor = 180 Ω . Supply voltage = 5 V. Pin ID: short leg = cathode.

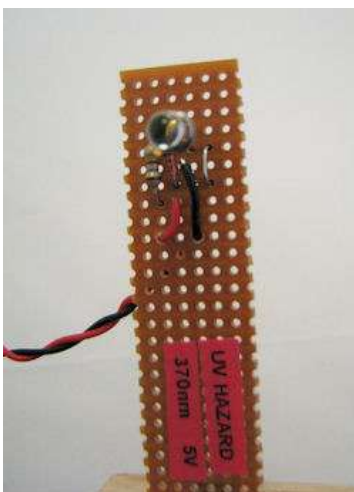

UV LED, Marl 260018, on 0.1" stripboard supported by a groove in a wooden block.



Fluorescent Plate, Frederiksen, 3076.00.

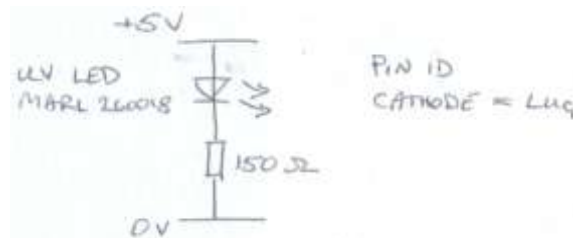

Circuit diagram: Running UV LED off 5 V supply.

UVR: Fluorescence and Phosphorescence

Purpose: To look at the phenomenon of fluorescence and distinguish between it and phosphorescence.

Information: Phosphorescence is an afterglow or delayed fluorescence after the bombarding radiation is over. Unlike fluorescence, the absorbed energy is not immediately re-radiated. The phosphorescent emission is at a longer wavelength than the stimulating radiation. Phosphorescence decays exponentially with time.

What you need: Fluorescing materials (photocopier paper, Luminescent Set [Leybold 469 82], tonic water, zinc sulphide screen, Glow-in-the Dark Film, washing tablet, bank note, mineral oil, geological specimens), UV Beads, UV LED, Red-Green-Blue LED set, UV filter, 5 V supply.

What to do:

1. Switch on the UV lamp letting it shine on the UV Beads in the lightbox. Briefly note what you see. Leave on. You will come back to it later.
2. Shine the UV LED on each of the six colours in the Leybold Luminescent Set. Which colours fluoresce and which ones also phosphoresce?
3. Now shine the red, green and blue LEDs on the six colours in the Leybold Luminescent Set and note what happens.
4. Which of the other fluorescing materials you have been provided with phosphoresce?
5. Look again at the UV Beads. Do they fluoresce, phosphoresce, or neither?
6. Switch off the UV lamp.

Equipment:

The set of six colours on the Luminescent Set (Leybold product 469 82) exhibit luminosity, fluorescence, or a mixture of fluorescence with phosphorescence.

Zinc sulphide screens (either Leybold product 468 72 or Frederiksen product 3075.00) exhibit phosphorescence. They can be used to detect infrared as well as ultraviolet radiation. This is shown in another experiment. Zinc sulphide, in ordinary form, does not fluoresce. The form that does has been doped with silver and is hard to obtain as a lab reagent.

Until quite recently phosphorescent screens were based mainly on zinc sulphide with added dopants. Lately, however, zinc sulphide has been replaced by new materials based on strontium aluminate. These continue to emit light for many hours. MUTR stock a product called Glow-in-the-Dark Film (SM1 016, £16.09) with strontium aluminate.



Luminescent Set, Leybold, 469 82.

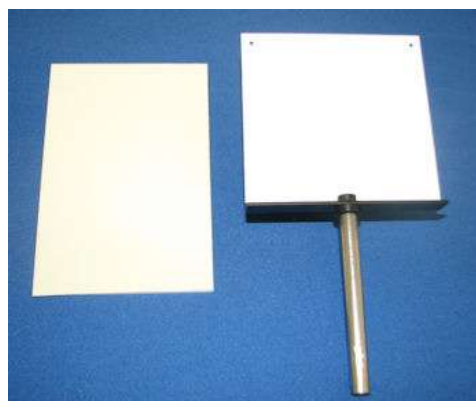

Zinc sulphide screens:
Leybold, 468 72 (Left)
Frederiksen, 3075.00 (Right)

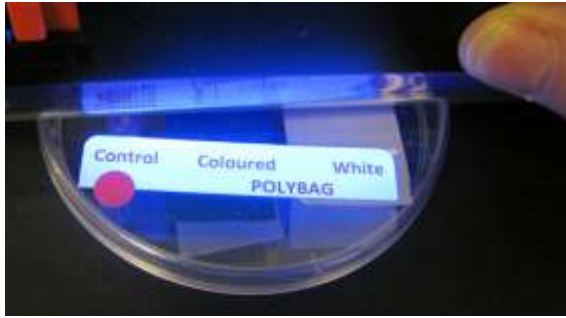

UV beads under UV light.

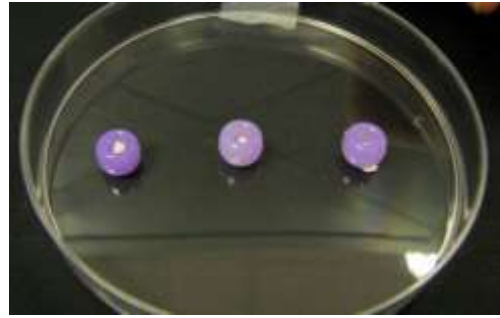

UV beads turned to different shades of purple under UV light.

UV Beads: Educational Innovations, #UV-AST, US\$6.95.
www.teachersource.com

Fluorescent Mineral Set: Educational Innovations, #RM-400, US\$14.25.

The hand-held UV lamp is Maplin product ZC10L. For a risk assessment, go to
<http://www.sserc.org.uk/members/SafetyNet/bulls/208/Maplin%20UV%20lamp%20risk%20assmt.rtf>



Maplin UV lamp, ZC10L

The UV longpass filter is a product from Edmund Optics (UV Filter Sheet) (NT39-426) (£10.13). The sheet measures 20" x 24". We have cut it up and mounted pieces in 35 mm slide mounts.



UV Filter cut from sheet supplied by Edmund Optics, NT39-426 and put into a slide mount.

UV LED: 370 nm, Marl 260018, Farnell part number 105-7079.

Series resistor = 180 Ω . Supply voltage = 5 V. Pin ID: short leg = cathode.

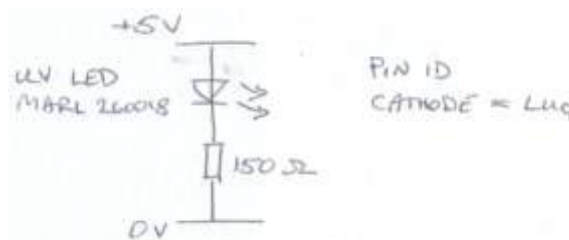

Circuit diagram: Running UV LED off 5 V supply.

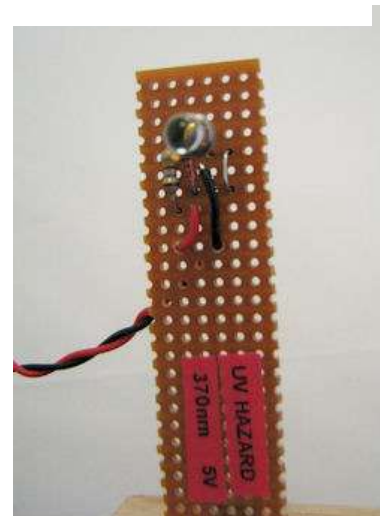

UV LED, Marl 260018, on 0.1" stripboard supported by a groove in a wooden block.

UVR: Reflection and refraction

Purpose: To show that ultraviolet radiation can be reflected and refracted.

Information: Here are some simple demonstrations, quick to do, showing that UVR can be reflected and refracted, but not polarized with the polarizing material supplied. The source is a UV LED. Radiation is detected by fluorescence on a paper screen. You can search for the invisible radiation with a slip of paper, moving it across the region where you expect to find it.

Because the radiation from the UV LED diverges, a converging lens should be used either to collimate or focus the light. The fact that this can be done shows the property of refraction. Having collimated the radiation, or focused it on a distant screen, you now have a beam of UVR to work with. It can then be directed at a mirror, prism, or polarizer.

What you need: UV LED, 5 V supply, paper screen, paper slip, (x2) converging lens ($f = 10\text{ cm}$), (x3) lens holder, prism (60°), prism (90°), (x2) concave mirror (x2) polarizer.

What to do:

1. Use a lens to direct a collimated beam at a concave mirror at 1 m. Redirect at another concave mirror at 1 m. Look for both foci.

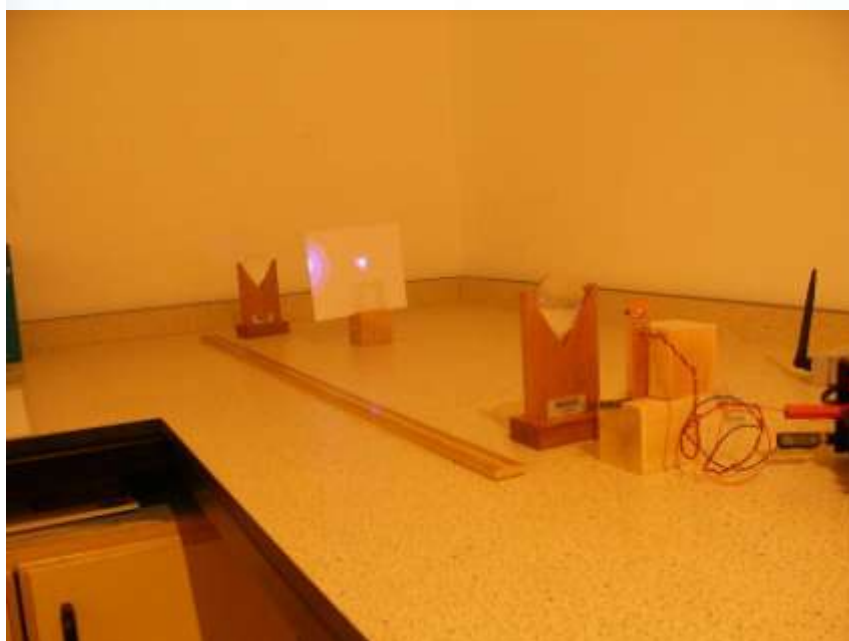
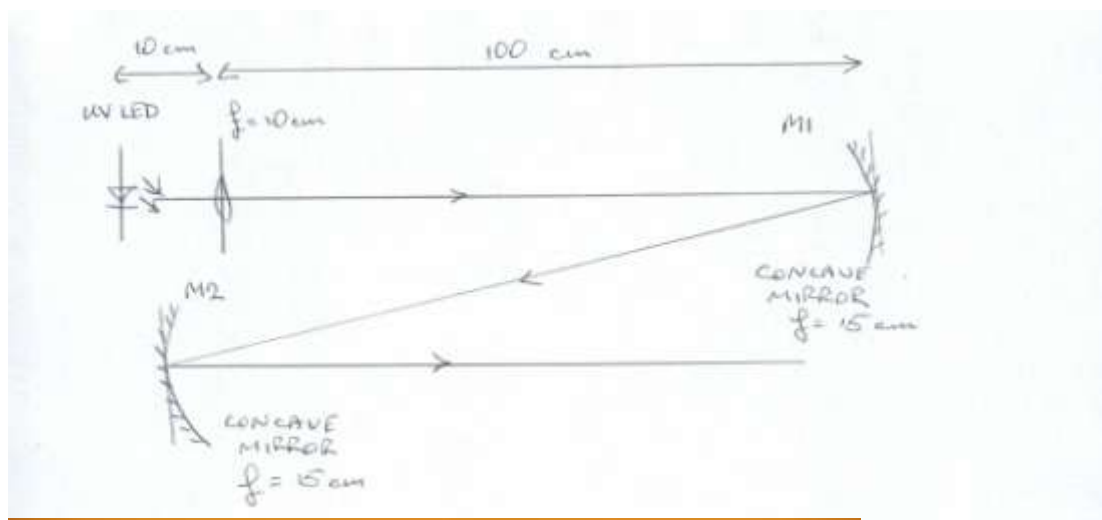

LED source, collimating lens, mirror M1 and screen at focus of M1. LH fluorescent screen image is edge of collimated beam. RH fluorescent screen image is focus of M1.

- Focus on a screen at 50 cm from the lens. Further refract the focused beam with a 60° prism, moving the screen to locate the deviated beam.

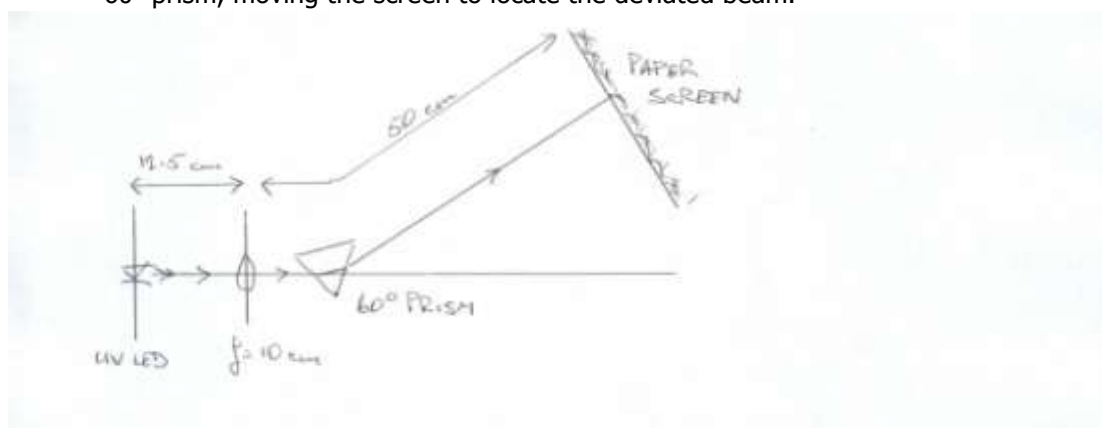

- Use one lens to collimate the beam, directing it on a screen at about 1 m. Place a 90° prism in the beam such the radiation is incident, normally, on the hypotenuse. The beam returns more or less to where it began. Rotate the prism a little to displace the beam to one side of the collimating lens. Set up a second lens alongside the first and focus the radiation.

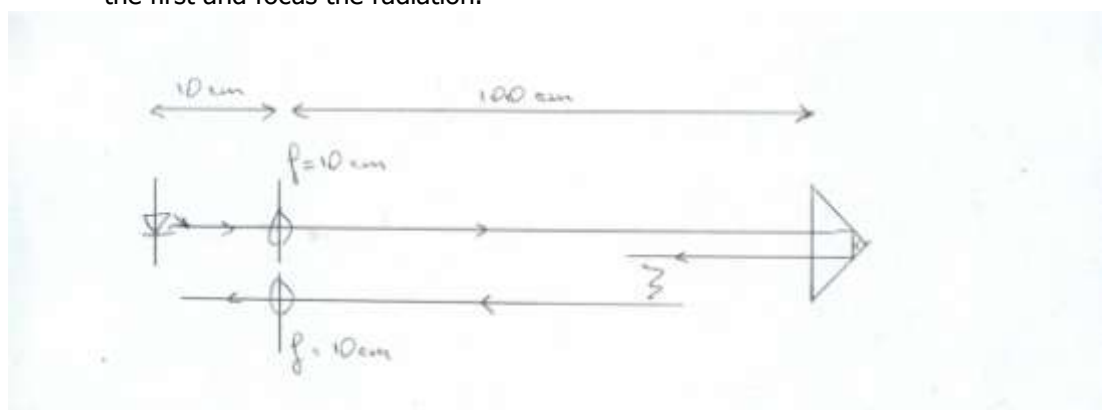

- Direct UVR at a polarizer. Is radiation transmitted? What do you conclude?

Equipment:

The experiments are done with standard optical components. One point to bear in mind when preparing the equipment is that all of the optical elements should lie in the same horizontal plane, which is liable to be set by your lens holder. If it is one of adjustable height, the lens can be raised or lowered to fit in with the other components on whatever stands they are on. But if the lens holder holds the lens at a fixed height, you should prepare supports for the LED, prism and mirrors to match this.

UV LED: 370 nm, Marl 260018, Farnell part number 105-7079. Series resistor = 180Ω . Supply voltage = 5 V. Pin ID: short leg = cathode.

Polarizing film: The UV absorption of commercial-quality polarizing film (visible linear polarizing film) (brown and gray) is greater than 99%. The transmission cut-off for both brown and gray varieties of polarizing film is 400 nm.

UVR: Optical displacement

Purpose: To shift a UV beam sideways by passing through a rectangular water tank, which is then rotated.

Information: This demonstration of refraction is based on the well-known phenomenon that when a rectangular glass block on which a ray of light is incident is rotated the ray emerging from the block is displaced from its original path. There are two changes from the ordinary experiment. One is that we substitute a collimated beam of UVR for a ray of light. The second is that a rectangular water tank replaces the glass block.

What you need: UV LED, spherical lens ($f=10\text{cm}$), lens holder, rectangular Perspex tank, turntable (optional), 5 V supply.

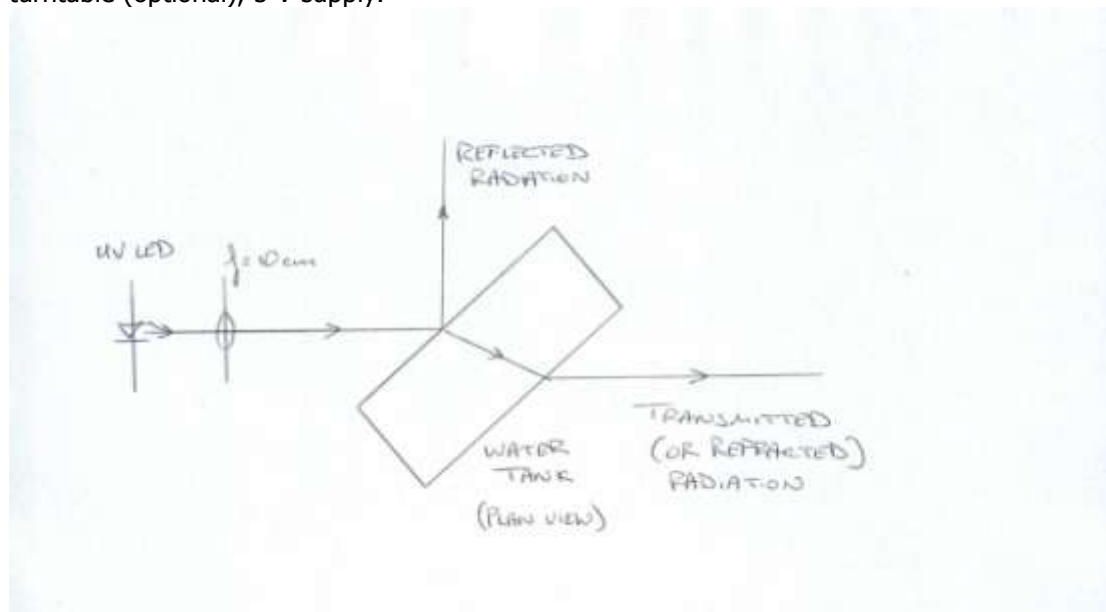
**What to do:**

1. Set up the lens in front of the UV LED and adjust to collimate the radiation. Direct it to fall on a paper screen at about 1 m. Its presence is shown by fluorescence.
2. Place the tank in the radiation with the beam normal to its length. (If you have a suitable turntable – see below – sit the tank on it so that it is easy to turn.)
3. Part fill the tank with water such that its level is above the height of the UV radiation.
4. Turn the tank, noting that the refracted beam is displaced sideways. (Beware of the reflected radiation harming you or others. You may have to erect shields.)
5. Set up a second paper screen on which to view UV radiation reflected off the front surface of the tank.
6. Change the angle of incidence. How do the intensities of the two beams, refracted and reflected, compare with one another with increasing angle of incidence?

AH Investigations:

1. Compare the lateral displacement of the refracted radiation with the angle of incidence and derive a value for the refractive index of water. Compare with other wavelengths.
2. Compare the irradiances of the refracted and reflected components with the incident radiation and angle of incidence.

Equipment:

The Rectangular Perspex Tank is a Frederiksen product (3015.00) (also called Light Refraction Vat).

The low turntable should be of the sort that turns on a ball race near its perimeter.

UV LED: 370 nm, Marl 260018, Farnell part number 105-7079. Series resistor = 180 Ω .
Supply voltage = 5 V. Pin ID: short leg = cathode.

Safety:

Set up barriers to stop the reflected beam leaving the work area.



Apparatus showing UVR displacement.

UV LED source (bottom RHS) directed at collimating lens. The UV beam is partially transmitted through the water tank and falls on the paper screen beyond the sink. The vertical black line on the screen shows the amount of displacement. Some of the radiation is reflected off the front wall of the tank. The reflected light forms a fluorescent patch on the screen at the RHS of the image.



Different aspect of UVR displacement.

UVR: Critical angle of water

Purpose: To show total internal reflection and measure the critical angle of water.

Information: A collimated beam of UVR is directed horizontally into one end of a rectangular tank of water, and is incident on a submerged mirror. The mirror is tilted to reflect the beam out of the water, its presence being found by fluorescence on a paper lid. The mirror is rotated so as to increase the angle of incidence at the surface of the water. The fluorescence disappears abruptly at the critical angle. The UV radiation has undergone total internal reflection and can be found emerging downwards out of the tank's front end.

What you need: UV LED, spherical lens ($f=10\text{cm}$), lens holder, rectangular Perspex tank, rotatory mirror, 5 V supply, half sheet of A3 paper cut lengthwise (about $30 \times 12 \text{ cm}$).

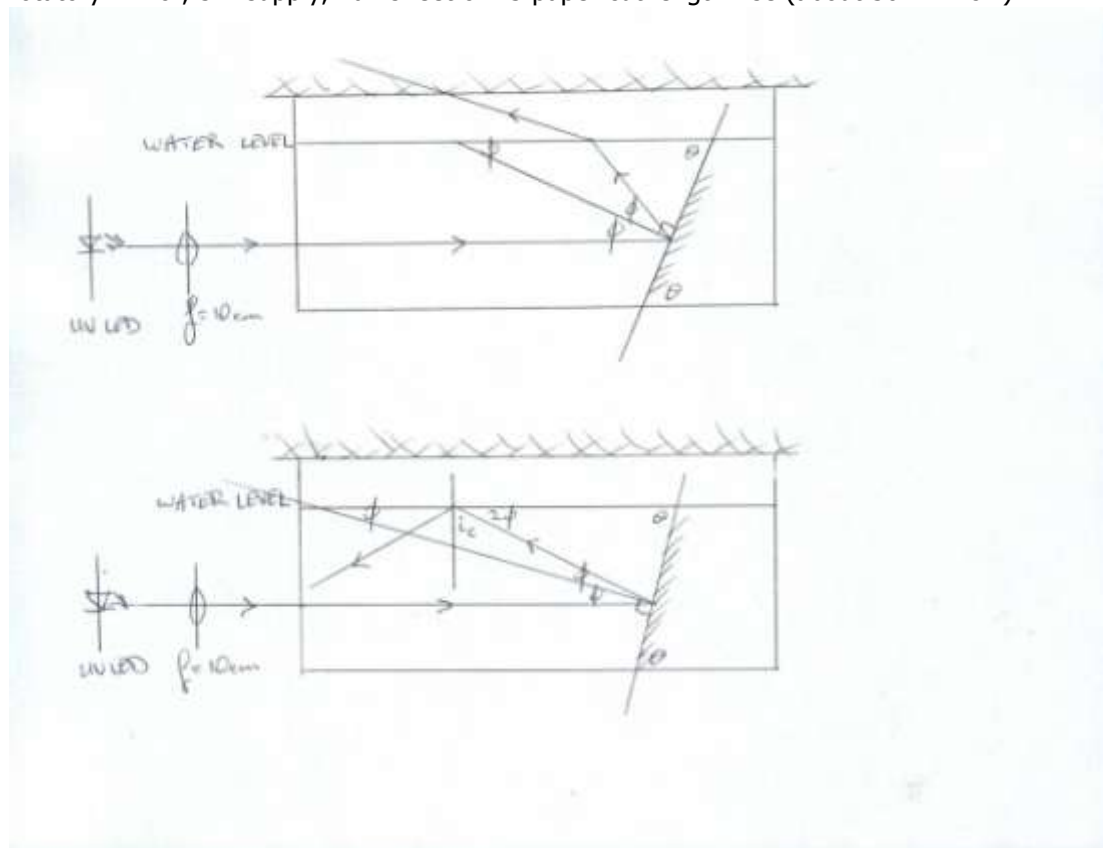

$$\phi + \theta = \frac{\pi}{2}$$

$$\Rightarrow 2\phi = \pi - 2\theta$$

$i_c = \text{critical angle}$

$$\rightarrow i_c = \frac{\pi}{2} - 2\phi$$

$$\Rightarrow i_c = \frac{\pi}{2} - \pi + 2\theta$$

$$\Rightarrow i_c = 2\theta - \frac{\pi}{2}$$

Measure the angle of inclination of the mirror θ to derive the critical angle of water.

What to do:

1. Set up the lens in front of the UV LED and adjust it to collimate the radiation so that it is incident and normal to one end of the water tank. (The UV beam should be horizontal and centred along the length of the tank.)
2. Place the rotatory mirror in the water at the far end of the tank to intercept the UV radiation.
3. Make two sharp folds in the sheet of paper each parallel to and about 15 mm from the long edges. This gives the paper the rigidity it needs to lie flat along the length of the tank. It sits on the tank, partly covering it, and is a translucent, fluorescent lid. The mirror's pointer should project freely to one side of the paper lid, letting the mirror be rotated.
4. Rotate the mirror to reflect the UVR vertically upwards. Find its position on the screen by fluorescence.
5. Slowly turn the mirror, letting the angle of incidence at the surface of the water increase gradually. As you do this follow the refracted beam by noting its changing position on the lid.
6. The refracted beam disappears at the critical angle. Steady the pointer with a prop. Measure the angle between the pointer and water surface and calculate the critical angle for 370 nm radiation.

AH Investigations:

Refine the method to derive the refractive index of water for UV and other optical radiations.



Apparatus to measure the critical angle of water with UV radiation.

Equipment:

The Rectangular Perspex Tank is a Frederiksen product (3015.00) (also called Light Refraction Vat). It is supplied with a perspex prop that rests snugly across the top of the tank.

The Rotatory Mirror is another Frederiksen product (3025.00). The pointer is fitted orthogonally to the plane of the mirror. It projects out of the tank and can be rested against the prop. Being not quite long enough, you should extend it by splicing a longer metal rod to it with twine. To prevent the Rotatory Mirror from corroding, it should not be left submerged for any more than a few hours and should always be removed from water and dried after use.

UV LED: 370 nm, Marl 260018, Farnell part number 105-7079. Series resistor = $180\ \Omega$.
Supply voltage = 5 V. Pin ID: short leg = cathode.



Figure description: Apparatus to measure the critical angle of water with UV radiation. The UV LED source is on the right. The collimating lens is 10 cm from the source. The water tank is elevated on wooden blocks so that the collimated beam projects on the rotatable mirror at the far end of the tank. The lever arm is orthogonal to the plane of the mirror and projects out of the tank to rest on a spar straddling the tank's walls. The tank top is partially covered with a paper lid on which any emergent radiation causes fluorescence.

UVR: Diffraction and interference

Purpose: To produce interference fringes with UVR and a diffraction grating; to determine the wavelength of the radiation.

Information: A UV LED is pointed at a sheet of graph paper taped to a vertical board about 50 cm distant and the radiation is focused on the screen with the lens. The diffraction grating is placed immediately in front of the lens, giving fringes. The lens is readjusted to sharpen the images. The wavelength is derived from $d \sin \theta / n$.

What you need: UV LED, spherical lens ($f=10\text{cm}$), lens holder, diffraction grating (80 lines/mm), 5 V supply, graph paper.

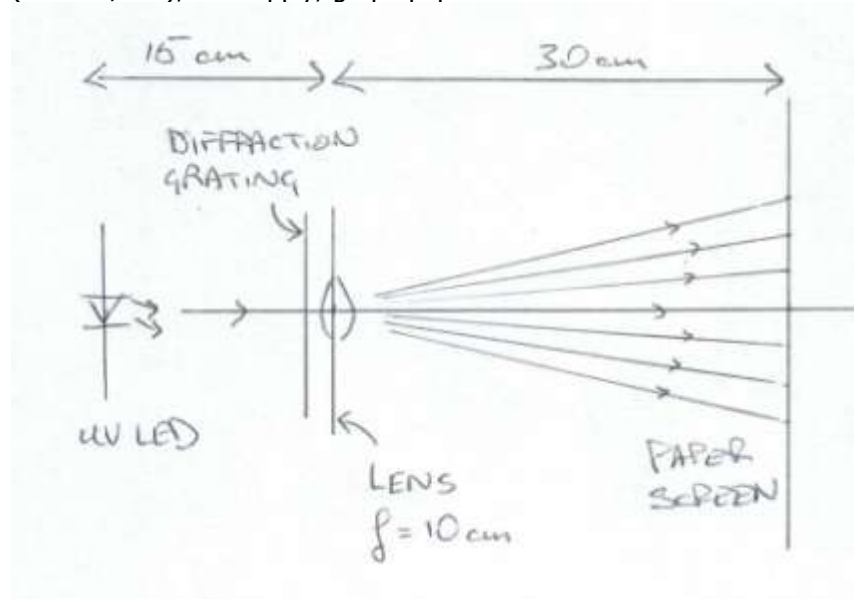
**What to do:**

1. Set up the lens in front of the UV LED and adjust it to focus the radiation on the screen of graph paper 30 cm distant. (The UV beam should be horizontal and normal to the screen.)
2. Place the diffraction grating immediately in front of the lens. Bright fringes will appear on the screen.
3. Readjust the lens to sharpen them.

AH Investigations:

Refine the method to derive the wavelength of UV and other optical radiations.

Equipment:

UV LED: 370 nm, Marl 260018, Farnell part number 105-7079. Series resistor = 180 Ω .

Supply voltage = 5 V. Pin ID: short leg = cathode.

Diffraction grating: In this experiment, a grating of 80 lines/mm is preferable to one of 300 lines/mm as the coarser one gives many more fringes. This helps to make the educational point that this is an interference effect. Furthermore the analysis is helped by the extra data.

UVR/Visible/IRR: Diffraction, interference and wavelength

Purpose: To produce sets of interference fringes with ultraviolet, visible and infrared radiations.

Information: A specially designed LED array with visible and invisible sources spaced 3 mm apart was constructed. The LEDs from top to bottom were UV, green, red and IR. Sets of parallel interference fringes were produced with a diffraction grating and by focusing the light on a white paper screen. The UV fringes are made apparent by fluorescence, lying beneath the ones of red and green. The IR fringes have to be searched for with the photodiode in the region just above the line of red ones.

What you need: LED array, spherical lens ($f=10\text{cm}$), lens holder, diffraction grating (300 lines/mm), photodiode, 5 V supply, multimeter.

What to do:

1. Set up the lens in front of the LED array and adjust it to focus the radiation on the paper screen 30 cm distant. (The radiation should be horizontal and normal to the screen.)
2. Place the diffraction grating immediately in front of the lens. Three parallel sets of bright fringes will appear on the screen.
3. Readjust the lens to sharpen them.
4. Where do you expect to find the infrared fringes?
5. By how many millimetres will the IR fringes be displaced upwards from the red ones (centre to centre)?
6. Hunt for the IR fringes with the photodiode.

Equipment:

The four LEDs were mounted in close proximity to each other on stripboard. Except for the UV LED, which had a 5 mm diameter lens, the others all had 3 mm lenses to reduce their separation to a minimum. They were wired to adjacent rows, 0.1" apart, in a diagonal. This meant that the stripboard has to be held diagonally to have the LEDs in a vertical line. The LEDs all have narrow emission angles to gather as much light with the lens as we can.

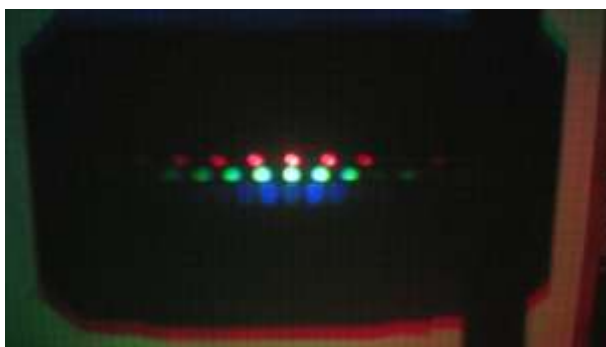

Interference fringes with red, green and UV LED sources.

Radiation	Wavelength (nm)	Manufacturer's product code	Supplier	Order code	Series resistor (Ω)
Ultraviolet	370		Marl	260018	150
Green	524		Farnell	423-7869	120
Red	639	-	Farnell	-	180
		-	Rapid	72-8976	
Infrared	950	Siemens SFH409	Rapid	58-0400	180

The detector is a Siemens phototransistor, SFH309, from Rapid Electronics (58-0425) with daylight blocking filter. The device is reverse biased at 5 V. There is a series resistor of 10 k Ω across which the voltage is measured. Voltage is proportional to the photocurrent, which is a linear function of light intensity.

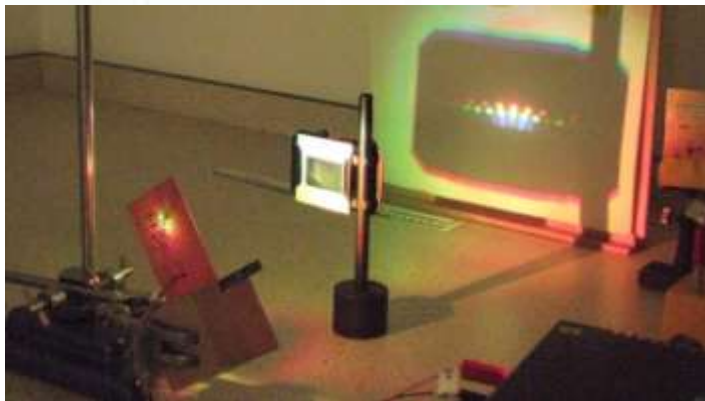
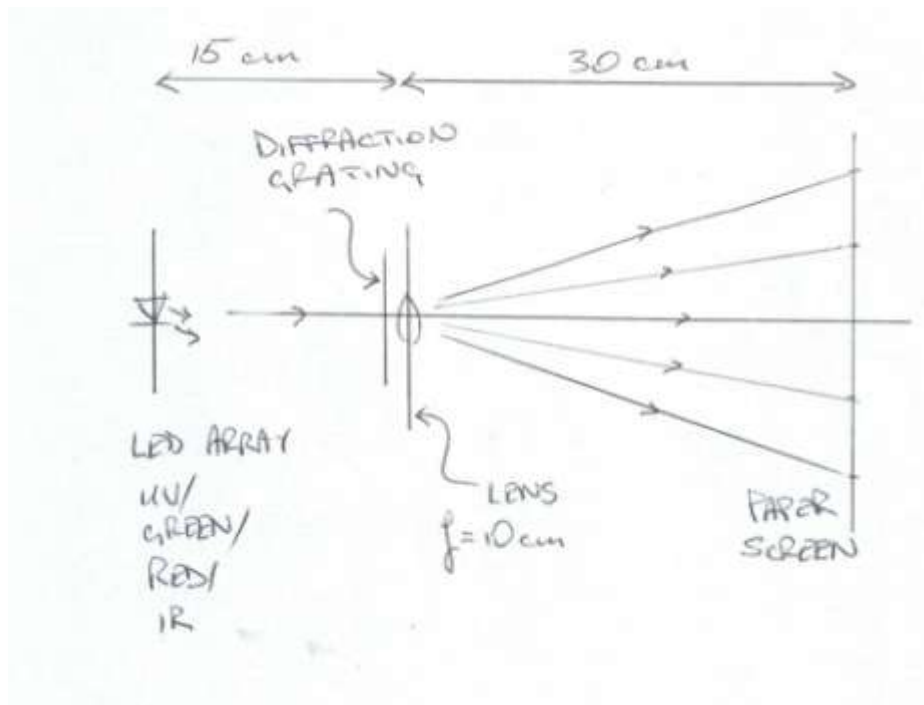

LED array, diffraction grating, lens and arrays of visible fringes.



LED array on stripboard.

UVR/Visible: A spectrum with an invisible component beyond violet

Purpose: To produce a spectrum which includes both UVR and visible components from a hot filament source.

Information: Light from a hot tungsten-filament lamp is refracted and dispersed by a prism giving a spectrum on a 2-part screen (Leybold product 46942), which is split horizontally, one half a fluorescing material and the other half a non-fluorescing diffuse reflector.

The lamp is a Compact Light Source. It has a quartz halogen bulb emitting a mixture of UVR, visible and IRR. Only the UVR and visible emissions are made use of in this experiment.

The spectrum straddles both parts of the screen. One half shows a diffuse reflection of the irradiation, the UV part being invisible. The other half the result after fluorescence, the UV part having been turned visible by fluorescence, the violet to green parts shifted to longer wavelengths and the yellow to red parts as diffuse reflections, without a change in colour, of the incident radiations.

When a UV filter is placed in front of the source, the spectrum's UV component is removed and the fluorescence it causes stops.

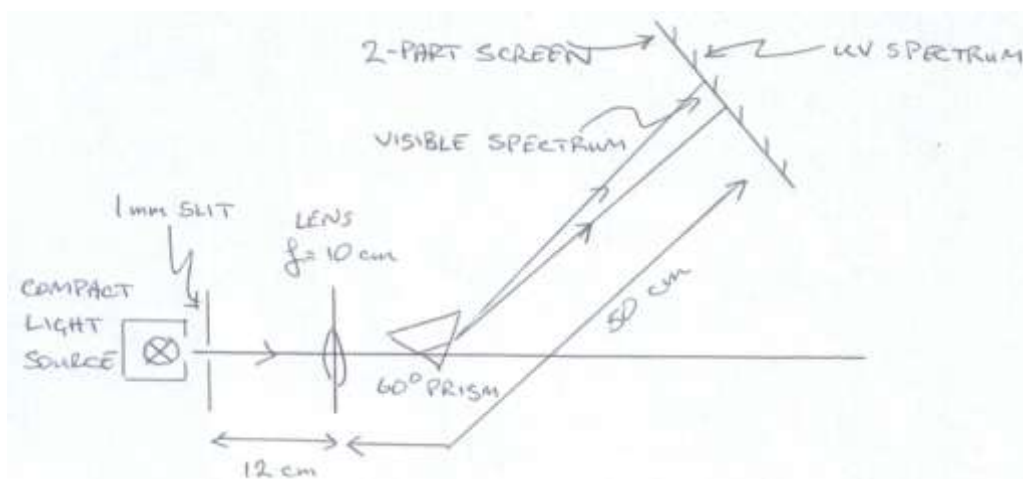

Plan of apparatus with principal rays.

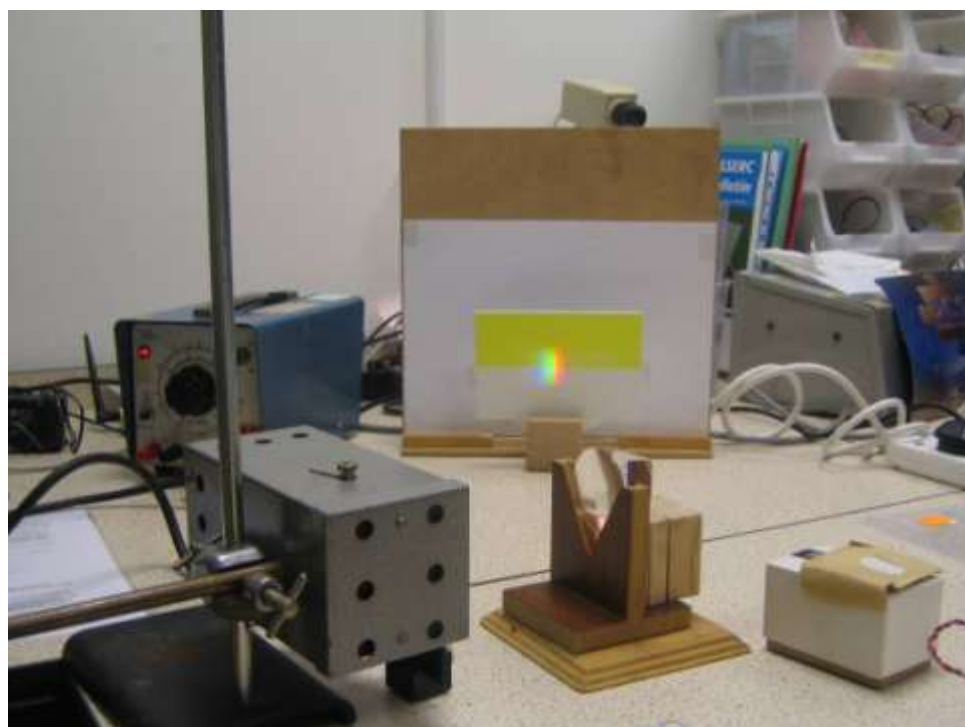

Photograph of apparatus. The prism sits on a wooden block and is hidden behind the lens.

What you need: Compact Light Source, slit (1 mm width, metallic), spherical lens ($f=10$ cm), prism (60°), 2-part screen (Leybold, 46942), UV filter (blocks UV), power supply (12 V, 8A).

What to do:

1. Switch on the Compact Light Source such that one open window on its enclosure allows light to flood horizontally across the work bench.
2. With the metallic slit aligned vertically, place it directly in front of this window. The slit can now be looked on as the effective optical source in this demonstration.
3. Place the lens about 12 cm in front of the slit to give a focused image on a paper screen about 50 cm from the lens. How wide is the image (by theory and by measurement)?
4. Place the prism in front of the lens and adjust to give a pleasing spectrum, having repositioned the screen such that the path length to the lens is still about 50 cm.
5. What is the maximum overlap of one colour over another?
6. Replace the paper screen with the 2-part Leybold one such that the division between the parts bisects the spectrum horizontally. That is to say, both parts of the split screen should be irradiated by all the colours in the spectrum.
7. Is there evidence that the lamp emits ultraviolet radiation?
8. Hold the UV filter in the radiation somewhere near the slit? What colours does it absorb?



2-part screen, Leybold, 46942.

Equipment:

The product name for the 2-part screen is the Fluorescing Screen (Leybold product, 46942).

The UV filter is a product from Edmund Optics (UV Filter Sheet) (NT39-426) (£9.46). The sheet measures 20" x 24". We have cut it up and mounted pieces in 35 mm slide mounts.

Compact light source: 100 W halogen lamp: Harris, B8H76839, £90.25.

Try also S&C: Light Source, XOP 560 630, £184.13 – has a much better spec than above. (This is the Frederiksen product 2800.50 Experiment Lamp.)

Prism: For best resulting visible spectrum: Edmund Optics, Equilateral prism, 30 mm side, $n=1.785$, SF11 flint glass, product code L47-278, £71.25. SF11 does not transmit below 370 nm. Frederiksen also supply a flint-glass prism with 30 mm sides, 2985.30, which is stocked by DJB (D2-2985.30, £68.00). Crown glass gives a less-well dispersed spectrum, but transmits UV down to 300 nm.

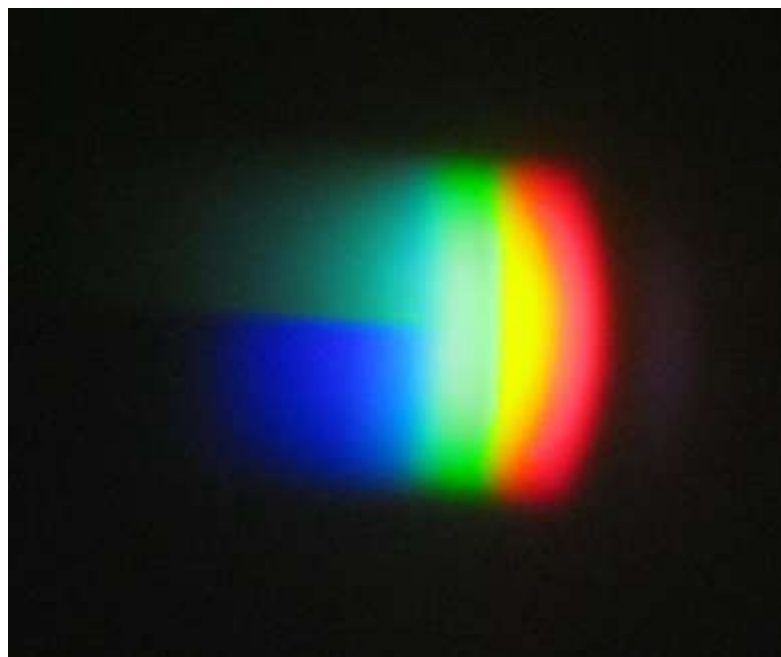

Spectrum on a 2-part screen. The top half fluoresces; the bottom part does not. However the image is misleading. While the photographic image in the bottom half is a fair representation of what the eye sees, in the top half it is not. The upper part, as seen by the eye, extends far to the left of the non-fluorescing part, but, because of contrast, is invisible in the photograph.

UVR: To discharge an electroscope by photoemission

Purpose: To show the photoelectric effect by irradiating a zinc plate on a charged electroscope with ultraviolet radiation from LED sources. The discharge when the charge on the charged plate is negative is evidence of photoemission. The threshold for photoemission is found from the highest waveband seen to cause it.

Information: The three UV LEDs have peak emissions of 265, 280 and 330 nm and wavebands of 20 nm. That is to say most of the optical energy emitted by the 330 nm LED has wavelengths between 320 nm and 340 nm. They are therefore narrow-band sources. By finding which LED or LEDs cause photoemission, we can find, to within about 10 nm, the threshold wavelength for photoemission from zinc.

The electroscope is charged negatively with the electrophorus and discharged by irradiating the freshly-cleaned zinc plate with either the 265 or 280 nm LEDs, but not with the 330 nm LED. This shows that photoemission only occurs if the wavelength is less than about 300 nm. Zinc has a work function¹ of 4.24 eV, indicating that the threshold for photoemission is 292 nm.

The Frederiksen electroscope (4410.00) is a large model of modern design, not having a gold-leaf, suitable for demonstration experiments.

The digital coulombmeter shows the sign of charge produced by induction with the electrophorus.

What you need: UV LEDs (265, 280 and 330 nm), (gold-leaf) electroscope, zinc plate, emery paper, electrophorus, coulombmeter, 12 V power supply.

What to do:

1. Clean the zinc plate, rubbing hard for about 30 s. Place the zinc plate on the electroscope.
2. Charge the electrophorus. Use the coulombmeter to check charge polarity.
3. Charge the electroscope with negative charge.
4. Irradiate the zinc plate with light from the 265 nm LED. Does the electroscope discharge?
5. Repeat for the other LEDs.
6. Charge the electroscope with positive charge and irradiate the zinc plate with 265 nm radiation. Does the electroscope discharge?
7. Summarize your findings?



Irradiating the zinc plate on a Frederiksen electroscope, 4410.00

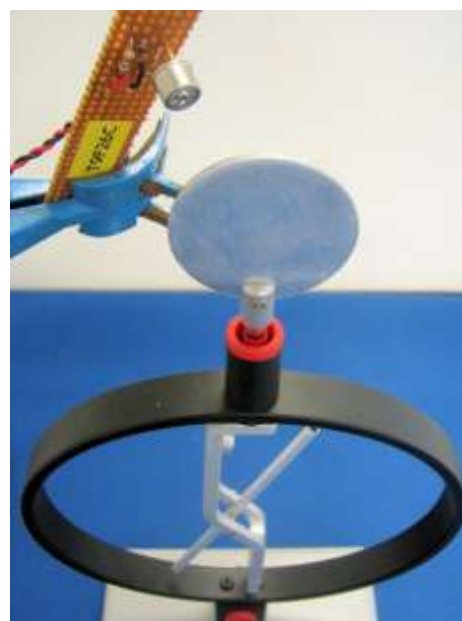

Irradiating zinc plate with 265 nm radiation.

¹ Kaye and Laby (1966) gives 4.24 eV. Other references give 4.33 eV and 3.63 eV.

Equipment:

Electroscope: Frederiksen, 4410.00 (UK supplier is TimStar)

Zinc Plate: Frederiksen, 4410.03 (UK supplier is TimStar)

UV LED PRODUCT DETAILS: (withdrawn from sale in 2010, replaced by other type of LEDs)

T9F26C, 265 nm +/- 10 nm, 300-400 uW: 112.14 euros. Series resistor = 330 Ω .

T9F28C, 280 nm +/- 10 nm 550-650 uW: 70.77 euros. Series resistor = 390 Ω .

T9F34B, 340 nm +/- 10 nm, 60-200 uW: 35.93 euros. Series resistor = 470 Ω .

Shipping and handling: 16 euros (post) or 42 euros (FedExpress)

Supplier: Roithner Lasertechnik: www.roithner-laser.com

The LEDs are energized at 12 V d.c. from a voltage-regulated supply.

REPLACEMENTS:

UVTOP255-HL-TO39, 255-264 nm,

260 euros

UVTOP280-HL-TO39, 280-290 nm, 167 euros

UVTOP295-HL-TO39, 295-305 nm, 148 euros

UVTOP310-HL-TO39, 310-320 nm, 130 euros

UVTOP335-HL-TO39, 335-345 nm, 102 euros

Safety:

UV radiation is probably carcinogenic to the skin and at wavelengths below 315 nm is highly dangerous to the skin.

UV radiation is highly dangerous to eyesight, the risk increasing with fall in wavelength.

Do not irradiate skin or eye. Do not look into a LED emitting UV radiation.

UVR and visible: Neon lamp induced to strike by photoemission

Purpose: If light is shone on a neon lamp energized at a few volts below its striking voltage the lamp can be caused to strike [1]. The effect is dependent on the frequency of radiation shining on the neon. From this it can be inferred that the radiation causes electrons to be ejected by photoemission from the electrodes on the neon. These free electrons are accelerated by the electric field across the gap between the electrodes. Collisions with neon atoms cause the gas to glow, signifying conduction.

Information: Neon indicators are cold-cathode discharge lamps with a low-pressure gas mixture of neon (99.5%) and argon (0.5%). When the voltage across the electrodes is increased to above a certain limit called the 'striking voltage' the lamp begins to conduct. With standard neons, there is a rosy-orange glow at the cathode (other types emit green light). The lamp can be energized off a.c. or d.c. supplies. If energized off a.c., there is a glow off both electrodes. If d.c., only one – the cathode – glows, showing the polarity of the supply. The striking voltage depends on the type of lamp. For small indicator lamps, it can be around 70 V or 90 V. For other types it can be up towards 200 V. Once lit, the running voltage can be 30% less.



Two neon lamps, electrodes showing.
TOP: SBC base, ring and disc electrodes.
BOTTOM: MES base, rod electrodes.

It has been reported that very old neon bulbs are unstable and do not fire at repeatable voltages [2].

The circuit must incorporate a current-limiting device. Usually this is a resistor in series with the lamp. In many types of neon a current-limiting resistor is built into the lamp - often for operation off the 230 V mains supply. With that type of lamp no external resistor is needed.

A neon indicator mounted in a suitable holder is energized from a variable-voltage HT supply. This type of supply is capable of delivering a high current at a high voltage. It could cause a dangerous, or even fatal, electric shock. Circuitry associated with it is said to be at 'hazardous live'. No conducting part should be touchable. Conductors must be insulated. Plugs and sockets must be shrouded. Please consult the safety guidance below.

The purpose of this experiment is showing that if a neon is lit by an external lamp the striking voltage can be reduced by a few volts because of photoemission (the emission of electrons from the cathode by the photoelectric effect). Here are the effects on the striking voltage produced by some different optical sources shining on a miniature neon with MES base.

Radiant source	Action	Comment
Dark conditions	Striking voltage is 73 V	Normal striking voltage
Ceiling lights, fluorescent tubes	Does not strike at 72 V	
Green laser, 1 mW	Does not strike at 71.5 V	
White Lumiled, 1 W	Strikes at 71.5 V	Photoemission is significant
Red Lumiled, 1 W	Does not strike at 71.5 V	
Green Lumiled, 1 W	Does not strike at 71.5 V	
Blue Lumiled, 1 W	Strikes at 71.5 V Also strikes at 70.5 V	Photoemission is significant
UV LED, 370 nm, low power	Strikes at 72.0 V, but not at 71.5 V	Photoemission is significant
UV fluorescent lamp, Maplin, ZC10L	Does not strike at 72.0 V	

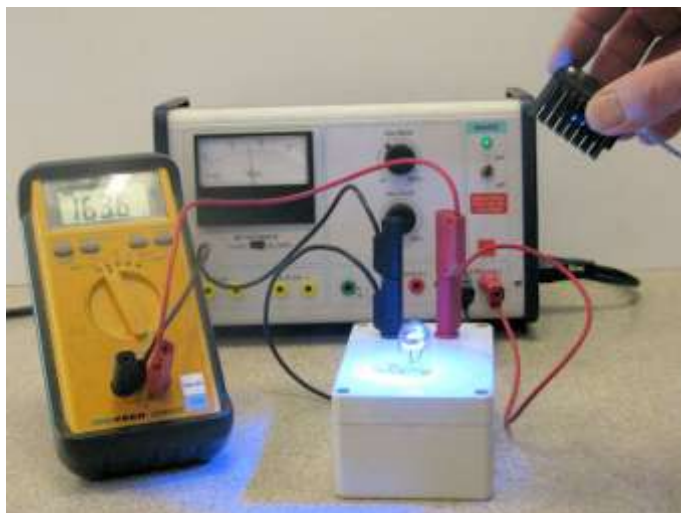

The set of four, white, red, green and blue Lumileds are high-power LEDs emitting intense radiation.

Photo opposite:
Neon lamp with SBC base set up in our home-made safety lampholder with shrouded sockets. The leads are fitted with stackable, shrouded plugs. Voltage is measured with a

reduced-function meter. The neon is being irradiated with blue light from a Lumiled.

Once a neon begins to conduct its cathode gets hot. This can cause the striking voltage to fall, presumably because of thermionic emission.

What you need: Neon lamp (with integral resistor) in safety lampholder, multimeter, HT supply (30 – 200 V), 4 x leads with shrouded, stackable connectors, high-intensity LEDs (white, red, green, blue) (preferably Lumileds), LT supply (5 V d.c. voltage-regulated).

What to do:

1. Connect the neon lamp in its safety lampholder across the high-voltage outlets of an HT supply. Connect a voltmeter set to read to 200 V d.c. in parallel across the neon.
2. Shade the neon from any intense source of light from the surroundings, whether sunlight or ceiling lights.
3. Switch on the HT supply with its HT control set at its lowest position. Slowly increase the voltage until the neon strikes. Record the voltage just before striking. The voltage may fall on striking.
4. Turn down the HT voltage to its lowest possible level, causing the neon to stop emitting light. Now turn up the voltage till it is about one volt below the striking voltage. Shine the white LED on the neon. This should cause the neon to strike. You may have to bring the external LED right up close to induce striking.
5. Repeat this procedure with the red, green and blue LEDs, noting which colours get the neon to strike below its striking voltage.
6. Find the lowest voltage at which each colour induces striking, if any.

Equipment:

Neon lamps with integral series resistor: (Do not use old neon bulbs [2].)

Supplier	Order code	Price (£)	Min.Qnty.	Base	Size (D x L) (mm)	Colour	Resistor
RS	655-9429	1.056	10	MES, E10	10 x 28	Green	Yes
RS	655-9435	0.603	10	MES, E10	10 x 28	Red	Yes
RS	106-385	1.82	1	SES, E14	14 x 52	Red	Yes
RS	104-761	0.673	10	MBC, BA9s	10 x 28	Red	Yes
Rapid	42-0322	0.49	1	Push-fit	12 x	Red	?
Rapid	42-0330	0.65	1	Push-fit	12 x	Green	?

Safety lampholder: The lampholder is made safe by recessing it within a sealed polycarbonate box (Rapid, 30-0770, £9.62, 115 x 65 x 55 mm). The lamp projects through a circular aperture in the lid shaped and placed to prevent ingress by fingers. There are shrouded socket outlets colour coded red and black on the top of the box through which the lamp is energized.

HT supply: 30 to 200 V d.c., continuously variable output. The equipment must be fitted with 4 mm shrouded socket outlets.

Lumileds: See SSERC Bulletin 205. Lumileds run off a 5 V d.c. voltage-regulated supply drawing 300 mA.

Voltmeter: Reduced function meter measuring voltage and resistance, but not current or other quantities. IDM61: RS, 697-4023, £38. [You are strongly recommended to have one reduced-function meter with which to measure voltage on a hazardous-live circuit.]

4 mm shrouded connectors: Use stackable plugs with non-retractable sleeves (meaning that the shrouds cannot be pulled back exposing the conductors). Plugs: RS, 248-7780, £4.28 (pair). Sockets: RS, 226-3051 (red), 226-3045 (black) £1.70.

Safety:

1. The risk of electric shock is tolerably low provided that the measures recommended above are applied. That is, the neon indicator must be sited in a safety lampholder, such as specified, insulated leads with shrouded connectors are used, and the voltmeter cannot be set to short-circuit the supply.
2. An HT supply should not be used by children at Years below S5. It can be used at S5 or S6 under supervision and after instruction. Please refer to the HT-safety guidance in Bulletin 208.
3. The neon lamp has an integral resistor.

Curricular points:

1. Demonstration experiment: This demonstration must be tried before showing to students because it is subtle and sensitive.
2. AH Investigation: Students are unlikely to find a relationship between the striking voltage and wavelength of light used to induce the neon to strike. Therefore, if it were to be the subject of an investigation, the student should be prepared for failing to find a relationship.

References:

1. Adolf Correl, "Simple photoelectric effect", *Physics Teacher*, 44, 310-311 (May 2006).
2. Jeffry Goldader, Letter: "Tweaking 'Simple Photoelectric Effect' Demo", *Physics Teacher*, 44, 406 (October 2006).

UVR and visible: Millikan's photoelectric experiment and Planck's constant

Purpose: To show that the stopping voltage of photoelectrons has a linear dependence on the frequency of radiation on a photoemissive cell and derive a value for Planck's constant.

Information: One of the paradoxes of the experimental work done by Philipp Lenard (1902) on the photoelectric effect was the discovery that the maximum kinetic energy of photoelectrons increases with a rise in frequency of the incident light. The paradox was explained by Einstein (1905) with his theory on the quantization of radiation and resolved by Millikan (1916) with his photoelectric experiment. The relationship predicted by Einstein and confirmed by Millikan was:

$$e\Delta V_s = h\nu - W_0$$

where e is the electronic charge, ΔV_s is the stopping voltage, h is Planck's constant, ν is the frequency of light and W_0 is the work function of the photocathode's surface metal.

Some details of this standard experiment are new and interesting [1]. Whereas the usual radiation source is a low-pressure mercury lamp, the emission lines being selected by optical filters or dispersion, in our arrangement the source is an array of LEDs, each LED being used one at a time. This exploits the feature that a LED can have a narrow emission band. The ones in our array were picked because their emission bands were indeed narrow – many being as little as 10 nm. Each LED source, if not strictly monochromatic, is nearly so.

Secondly we are using a phototube called 1P39, or 929, made by RCA in the 1950s for TV cameras [2]. The cathode material is Sb_3Cs (called S-4) and is highly sensitive to light. Its peak sensitivity is 400 nm, with a wavelength limit of 700 nm. Thus it is sensitive to the whole visible waveband and the near ultraviolet.

The *quantum efficiency* of a photocathode is the average number of photoelectrons per quantum absorbed. For an S-4 cathode it can be 0.1 at the maximum sensitivity.

The anode of the phototube is the central electrode shaped like a vertical rod. The cathode is the curved surface facing the anode. The phototube has a 3 mm strip of black tape to shield the anode from light from an external radiation source (in our case a LED).

The phototube fits into an octal base. Pin 4 connects to the anode and pin 8 to the cathode. The other pins are unconnected. The keyway sits between pins 1 and 8. Light is incident midway between pins 4 and 5.

The electric circuit is conventional. A potentiometer is connected across a 3 V battery, which reverse biases the phototube (making the anode negative and cathode positive). A microammeter in series with the phototube records the current. It is used to register a null current. A voltmeter across the potentiometer records the biasing voltage.

What you need: Phototube (RCA type 1P39 or 929), circuit box with octal base, blackout tubing, 3 V battery, 2 x multimeters (one with a current range of 20 μA), LED array, UV LED (370 nm), 5 V d.c. supply (voltage-regulated).



RCA phototube type 929. A strip of black tape masks the anode from light. The curved metal sheet at the back of the tube is the cathode.



Photo opposite:
The phototube is mounted on an octal base on top of the grey box. The tube is screened from ambient light by a T-shaped tubular blackout. The tube is being irradiated with light from one LED on the array of LEDs.

What to do:

1. After inserting the phototube in the octal base, cover the tube with the blackout provided for it. The aperture should face the blackout strip that covers the anode. The laboratory should also be blacked out. The LED array should be clamped, horizontally, such that one LED is centred on the aperture to shine on the cathode.
2. Build the circuit. For the microammeter, use a multimeter set to read $20 \mu\text{A}$ d.c. For the voltmeter, use another multimeter set to read 2 V d.c.
3. To take a reading of the stopping voltage, irradiate the cathode with a LED and turn the biasing voltage up until the photocurrent just drops to zero. Record the stopping voltage. Repeat several times, each time starting with the biasing voltage much below the stopping voltage. Decide on the best value.
4. The peak wavelength of each LED source is marked. The spectral width of these LEDs is narrow (perhaps 10-20 nm). Derive the frequency.
5. Obtain values of stopping voltage for all the visible LEDs in the array.
6. Get a 370 nm UV LED (this is not on the array) and obtain its stopping voltage.
7. Graph your values of stopping voltage versus frequency. Does the graph support Einstein's relationship?
8. Obtain a value for Planck's constant.

Equipment:

RCA phototube: Either 1P39 or 929: Google to find a supplier. These phototubes are obsolete. The estimated cost is £40.

Octal base: RS 402-715, £1.53 (minimum quantity = 5) (called a 10 A Relay Socket).

LED array: Philip Harris product F4J73433, £73.50.

Home-made array components:

Item	Supplier	Order code	Unit price	Pack size
UV LED, 400 nm	SSERC	891	1.50	
Blue LED, 428 nm	Farnell	366-4636	0.63	
Blue LED, 458 nm	Farnell	366-4624	1.41	
Blue LED, 488 nm	Farnell	366-4569	1.41	
Bluish-green LED, 502 nm *	RS	228-1863	1.35	
Green LED, 524 nm	Farnell	302-7740	1.44	
Green LED, 574 nm	Farnell	325-5610	0.30	
Yellow LED, 589 nm *	Rapid	55-1666	0.27	
Red-orange LED, 615 nm	Farnell	301-5191	0.41	5+
Red LED, 630 nm *	Rapid	55-1664	0.25	
Red LED, 660 nm	Rapid	72-8982	0.15	
Deep red LED, 700 nm	Roithner	ELD-700-524	2.18	

UV LED: 370 nm, Marl 260018, Farnell part number 105-7079. Series resistor = $180\ \Omega$.
Supply voltage = 5 V. Pin ID: short leg = cathode.

Potentiometer: $1\ \text{k}\Omega$

Blackout: T-shaped tube. The vertical part is from a toilet-roll holder (48 mm diameter, cut to 100 mm length) painted inside and out matt black. The top of the tube is covered to block out light. The horizontal part is a black 35 mm film canister, end removed, centred 45 mm above the base to meet the middle of the cathode.

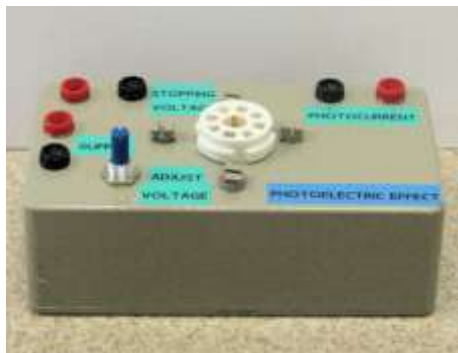

Circuit box with octal base.

Circuit box: This is a small plastic box with an octal base, $1\ \text{k}\Omega$ pot and three pairs of 4 mm sockets to each of the (1) battery (across pot), (2) voltmeter (across the variable pot output), and (3) microammeter (in series with the photocell).

References:

1. Wayne P Garver, "The Photoelectric Effect Using LEDs as Light Sources", *Physics Teacher*, 44, 272-275 (May 2006).
2. <http://mysite.du.edu/~etuttle/electron/elect30.htm>

IRR: Herschel's experiment on discovery of infrared radiation

Purpose: To disperse white light from a hot-filament lamp and show with thermometers that the spectrum extends beyond its visible bounds into infrared.

Information: This is a variation on Herschel's experiment on solar radiation. Having found a heating effect from a hitherto unknown agent beyond the red end of the visible spectrum, Herschel realised that the solar spectrum included an invisible radiation, which he called 'infrared'. In our version the source of optical radiation is a hot-filament lamp.

The spectrum from a high-power reflector lamp is cast on a white screen. A set of 4 black-bulb thermometers is suspended in the dispersed radiation close to the screen, their shadows showing on the spectrum. After 2 min irradiation there is a discernible difference in the readings. The thermometer outside the visible red has risen further than others in the visible spectrum. One concludes that it is being warmed by an invisible radiation beneath the red end of the visible spectrum.

The following diagram is erroneous. It was for an early setup. In our improved version (see photo overleaf), two aluminium reflectors stand immediately in front of the lamp. They are 4 mm apart, the gap forming a single slit. The spectrum is the focused image of this slit.

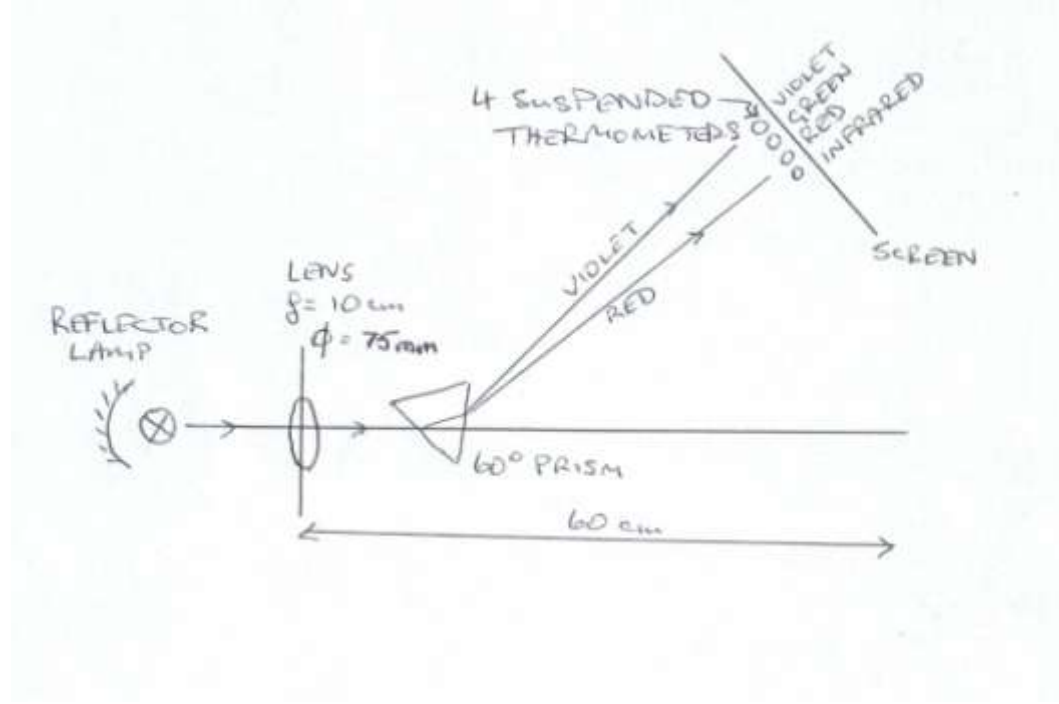

What you need: Reflector lamp, spherical lens ($f=10$ cm, dia.= 75 mm), prism (60°), 4 x black-bulb alcohol thermometers (0.1° division, 460 mm long), 2 x plane aluminium reflectors (210 mm square) on feet (from microwave kit).

Setting up:

The lamp should be set up with its axis centred on the condenser lens (a large-diameter glass lens with short focal length of 100 mm). Place the reflectors 10 mm from the front of the lamp to form a gap 4 mm wide. The gap acts as a single vertical slit. It becomes the source in our imaging system. With the lens 125 mm from the slit and a screen 500 mm beyond the lens, there should be a focused image of the slit on the screen. Adjust the screen to sharpen the image. Now place the prism in front of the lens and swing the screen round to capture the spectrum, keeping the same distance from the lens. Suspend four black-bulb thermometers by thin twine from a horizontal rod held above the spectrum by clamp stands. Carefully position the thermometers so that one is irradiated by violet, the second by green

and the third by red radiation. Confirm this is so by shielding each bulb with a slip of paper. Set up the fourth thermometer bulb outside the red edge of the spectrum.

What to do:

1. Start the experiment when the thermometers are at room temperature.
2. Read the thermometers to 0.1°C precision. Write down the readings.
3. Switch on the lamp for 2 min then switch it off.
4. Reread the 4 thermometers, writing down the readings.
5. Work out the temperature differences.
6. Is there evidence of an invisible radiation beyond the red end of the spectrum?

Equipment:

The reflector lamp came from Lightbulbs Direct (Infrared Reflector Lamp, 230 V, 275 W, ES, Clear, Product code 1318, £9.40).

Alcohol thermometers were dipped in matt-black paint to become black-bulb instruments. Ideally they should have a short range around room temperature with a precision of 0.1°C. Product suggestion: S&C, THM 060 010, -1/51°C, 0.1° division, 460 mm long, £10.85.

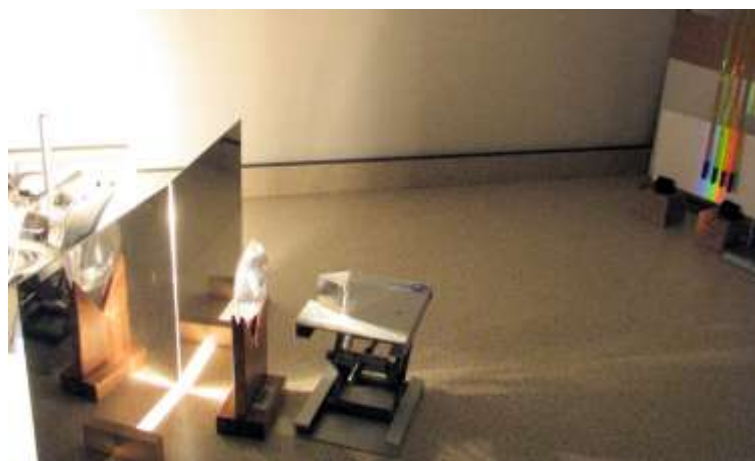

Layout of apparatus.



Because of the lens, there is a real image of the slit on the screen behind the 4 black-bulb thermometers. Because of the prism, the image shows colour dispersion.

Discussion: Typical temperature rises were 0.8°C at violet and green, 1.3°C at red and 2.1°C at infrared. In our version the reason for using four thermometers is to speed up the demonstration. You can get by with one or two. Herschel originally made do with two. One was kept shaded. The other was in the spectrum such that, by the movement of the sun, the black bulb was sequentially irradiated by violet through to red, then on to infrared.

IRR: A spectrum with an invisible component beneath red

Purpose: To disperse white light from a hot-filament lamp and show, with a webcam, that there is an invisible component beneath red.

Information: Light from a hot tungsten-filament lamp is refracted and dispersed by a prism giving a spectrum on a paper screen. The spectrum is also viewed with a webcam – one that has been altered – with its infrared-blocking filter taken out, and replaced with a daylight-blocking filter. The infrared image of the spectrum overlaps with the far-red visible spectrum and extends way beyond (or beneath) it where nothing is seen by eye.

The radiation source is a Compact Light Source. Its lamp is quartz halogen, emitting a mixture of UVR, visible and IRR. Only the IRR and visible emissions are made use of in this experiment.

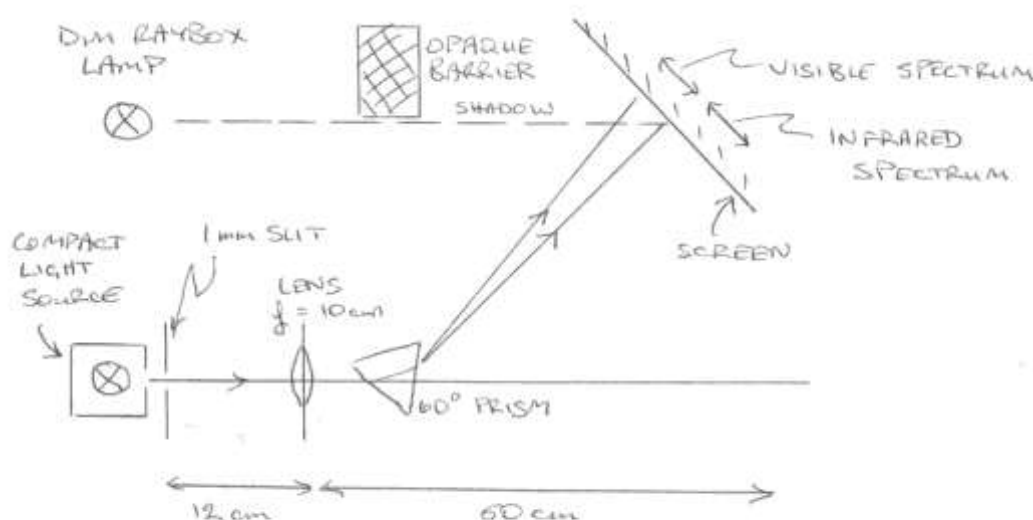

What you need: Compact Light source, single slit (1 mm width), spherical lens ($f=10$ cm), prism (60°), IR longpass filter, webcam with IR filter, laptop, RGB LED source, raybox lamp (run at 4 V), obstacle, white screen, power supply (12 V, 8 A), power supply (4 V, 2 A), power supply (5 V).

Setting up the spectrum:

1. Switch on the Compact Light Source such that one open window on its enclosure allows light to flood horizontally across the workbench.
2. Place the metallic slit, 1 mm wide, directly in front of this window. The slit can now be looked on as the effective optical source in this demonstration.
3. Place the lens about 12 cm in front of the slit to give a focused image on a paper screen about 50 cm beyond the lens. How wide is the image (by theory and by measurement)?
4. Place the prism in front of the lens and adjust to give a pleasing spectrum, having repositioned the screen such that the path length to the lens is still about 50 cm.
5. What is the maximum overlap of one colour over another?
6. Switch on the raybox lamp, operating it at just 4 V such that it glows dimly. Let it irradiate the screen and spectrum from a distance of about 40 cm.
7. Place an obstacle near to the screen such as to cast a shadow from the raybox lamp whose vertical edge is against the outside limit of the visible red spectral band. The shadow acts as a marker of the termination of the visible spectrum.

What to do:

1. Find out if the webcam can detect visible radiation by directing it at the blue, green and red LEDs, one by one, on the RGB LED circuit. Does it detect visible radiation?
2. Find out if the infrared filter stops or transmits visible radiation by holding it up against each LED, blue, green and red, one by one. Does it stop or transmit visible radiation?
3. Point the webcam at the spectrum.
4. Why is the shadow of the obstacle cast by the raybox lamp on the screen picked up by the webcam?
5. What is the chief difference between the visible spectrum and the one detected by the webcam? What inference can be made?
6. Place the IR longpass filter between the lens and prism such that radiation from the Compact Light Source is either stopped or transmitted through the filter. What changes, if any, take place to the visible spectrum and the one seen by the webcam? Does this support your inference?
7. Why is the spectrum as seen on the webcam not entirely to one side of the shadow mark?

Equipment:

Three power supplies are needed. They are for the (1) Compact Light Source (12 V, 8 A), (2) raybox lamp (12 V, 24 W) (run at 4 V), and (3) RGB LED circuit (5 V voltage-regulated).

The webcam is an Amazon product: 'LifeCam VX-3000' at £19.25.

The infrared longpass filter is an SEP product (SEP 204, £5.04). A larger filter is available from Edmund Optics (NT43-953, Optical Class Plastic Longpass Filter 2" x 2", £5.25).

Compact light source: 100 W halogen lamp: Harris, B8H76839, £90.25.

Try also S&C: Light Source, XOP 560 630, £184.13 – has a much better spec than above. (This is the Frederiksen product 2800.50 Experiment Lamp.)

Prism: For best-resulting visible spectrum: Edmund Optics, Equilateral prism, 30 mm side, $n=1.785$, SF11 flint glass, product code L47-278, £71.25. Frederiksen also supply a flint-glass prism with 30 mm sides, 2985.30, which is stocked by DJB (D2-2985.30, £68.00).



Spectrum as photographed by the webcam with its infrared-blocking filter removed. The shadow-line roughly marks the right-hand edge of the visible component of the lamp's spectrum. The bright white part is the infrared component.



Spectrum as photographed by the webcam with its infrared-blocking filter removed and a visible-blocking filter inserted. The shadow-line roughly marks the hidden right-hand edge of the visible component of the lamp's spectrum.

As the magnification of the lens is about $\times 4$ and the slit width is 1 mm, there is an overlap of 4 mm between adjacent colours.

The image shows that the infrared component of the lamp's output is more intense than the visible part. However the interpretation is difficult to quantify as (1) the wavelength sensitivity of silicon peaks in the near infrared and (2) infrared wavelengths are more tightly bunched than visible ones in a prism spectrum.

IRR: Refraction and reflection of infrared radiation

Purpose: to show that infrared radiation can be refracted, either by collimating or focusing with a lens; also to show that infrared radiation can be reflected off a mirror.

Information: In this experiment you will be working with radiation from an infrared LED in the near-IR waveband, which runs from 700 nm at the edge of visible red to 1,400 nm. This is the region used predominantly in telecommunications. Unlike ultraviolet, whose presence can be made apparent by fluorescence, there is no visual aid to mark the presence of infrared radiation. Thus infrared optics is harder to do than ultraviolet optics. A webcam would be the easiest way of finding the radiation. Failing that, and there is not a webcam available for you in this experiment, you just have to resort to a photodiode or phototransistor, one that's sensitive to infrared. The device supplied here has a filter to block visible radiation.

To assist finding the position of the IR beam, there is a visible yellow LED mounted 10 mm beneath the IR LED source. The visible radiation is an aid to locating the invisible light.

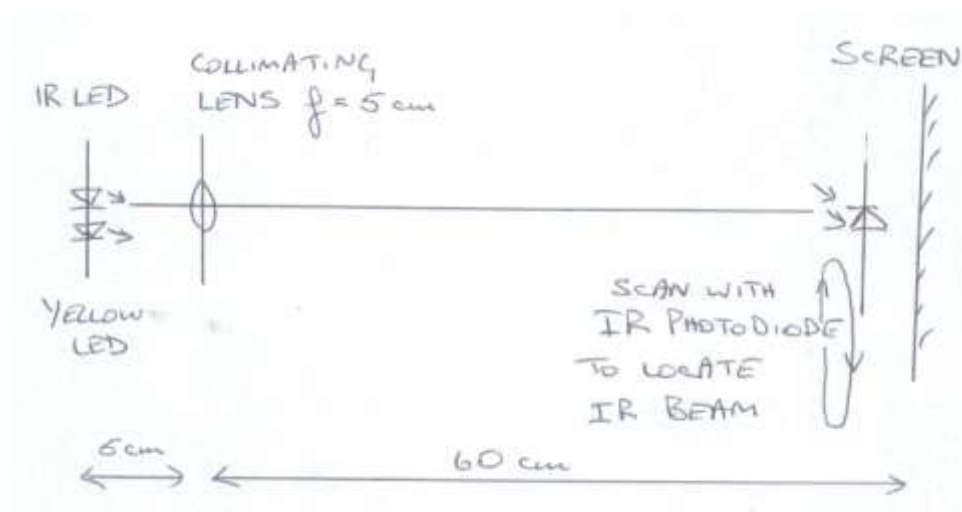

What you need: IR LED, yellow LED, Lens ($f=50$ mm, dia. 50 mm), IR photodiode, multimeter, 1.5 V cell, 5 V supply, IR filter, optical fibre, plane mirror.

Setting up:

1. Place the lens about 5 cm in front of the LED sources with its principal axis midway between the LEDs. Adjust the lens so that the yellow radiation has been collimated. This is apparent from the image on the screen 60 cm from the lens.
2. **QUESTION:** From their relative positions on the circuit board, how far apart are the centres of the infrared and yellow images on the screen?

What to do:

1. With your photodiode, search for and locate the infrared image on the screen. Find the position of maximum irradiation. Note the reading and relate its value to the following measurements.
2. Shield the yellow LED with paper. Has the infrared reading changed? Does visible radiation contribute to it?
3. Shield the infrared LED with paper. What is the reading? What is the source of the reading before the IR LED had been covered?
4. Shield both LEDs with the IR filter. Does the yellow image disappear? Does the IR reading change? What can you conclude?
5. Remove the lens, causing the screen to be bathed in diffuse yellow radiation. From what has happened to the reading what can you infer about infrared radiation, glass lenses and refraction?

More to do:

Having collected, collimated and focused infrared radiation with a lens, fix one end of an optical fibre to the IR LED and direct the other end at the photodiode showing that infrared can be transmitted through an optical fibre. Finish off this work by directing infrared from the fibre obliquely at a plane mirror and picking up the reflection with the photodiode.

Equipment:

Yellow LED: 590 nm, 5 mm lens, L-7113SYC, Rapid (55-1666)

Infrared LED: SFH409, 950 nm, Rapid (58-0400). Pin ID: short leg = cathode. Series resistor = $220\ \Omega$, $V = 5\ \text{V}$

Infrared phototransistor: SFH309T1, 800-1000 nm, Rapid (58-0425). Pin ID: short leg = cathode. Series resistor = $10\ \text{k}\Omega$, $V = -1.5\ \text{V}$ to $-5\ \text{V}$

The infrared longpass filter is an SEP product (SEP 204). A similar filter is available from Edmund Optic (NT43-953, Optical Class Plastic Longpass Filter 2" x 2", £5.25).

Multimeter: The multimeter detects the photocurrent by measuring the voltage dropped across a resistor in series with the reverse-biased photodiode. Do not set the meter to a higher sensitivity than to 0.01 V as stray light can result in background readings of a few millivolts.



Circuit with yellow and infrared LEDs..

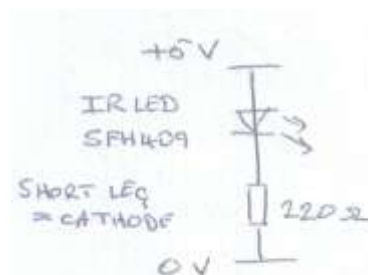

Circuit diagram: IR LED, SFH409.

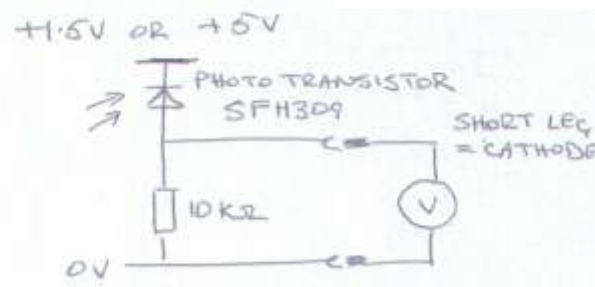

Circuit diagram: IR phototransistor, SFH309.

IRR: Diffraction and interference of infrared radiation

Purpose: to show that infrared radiation can be diffracted with a transmission grating, which results in interference fringes; to determine the wavelength.

Information: An infrared LED is pointed at a sheet of graph paper taped to a vertical board about 45 cm distant and the radiation is focused on the screen with the lens. The diffraction grating is placed immediately in front of the lens, giving fringes. The lens is readjusted to sharpen the images. The positions of the focus and fringes are found electronically with a photodiode. The wavelength is derived from $d \sin \theta / n$.

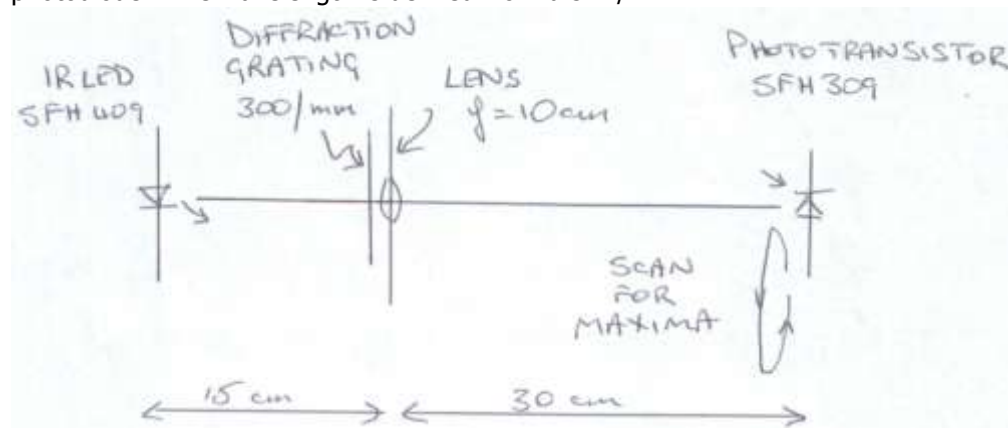

Schematic diagram of optical elements.

What you need: IR LED, spherical lens ($f=10\text{cm}$), lens holder, diffraction grating (300 lines/mm), IR photodiode, 5 V supply, multimeter, graph paper.

What to do:

1. Set up the lens 15 cm in front of the infrared LED and such that, in theory, the invisible radiation is brought to a focus on a graph paper screen 30 cm beyond the lens. (The radiation should be horizontal and normal to the screen.)
2. Place the IR detector on the spot where you expect the radiation to be focused. Search and locate the place where the intensity is greatest.
3. Adjust the lens slightly to maximise the reading on the meter.
4. Place the diffraction grating immediately in front of the lens. In theory a set of bright interference fringes are focused on the screen.
5. Where do you expect to find the infrared fringes?
6. Hunt for the IR fringes with the photodiode.

AH Investigations:

Refine the method to derive the wavelength of infrared and other optical radiations.

Equipment:

Infrared LED: SFH409, 950 nm, Rapid (58-0400). Pin ID: short leg = cathode. Series resistor = 220Ω , $V = 5 \text{ V}$

Detector: The detector is a Siemens phototransistor, SFH309, with filter blocking daylight. The device is reverse biased at 5 V (and operates down to 1.5 V). There is a series resistor of $10 \text{ k}\Omega$ across which the voltage is measured. Voltage is proportional to the photocurrent, which is a linear function of light intensity.

It should be possible to substitute a webcam for the photodiode.

The grating has 300 lines/mm and it produces a well-separated interference pattern.

If the detector is scanned through the region where you would expect to get interference fringes, five maxima can be found readily, being the zeroth, first and second-order fringes.

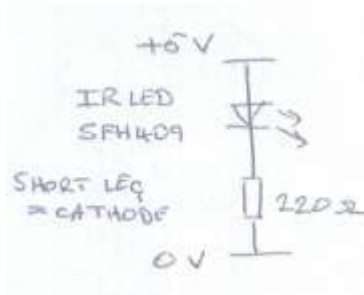

Circuit diagram: IR LED, SFH409.

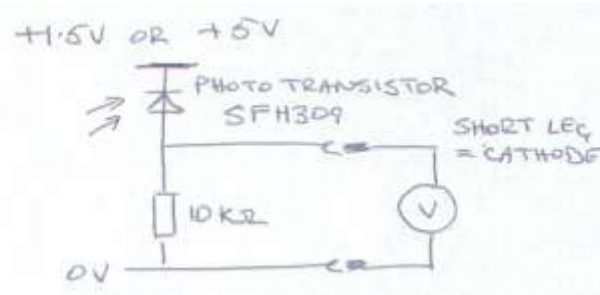

Circuit diagram: IR phototransistor, SFH309.

IRR: Reflection of infrared radiation

Purpose: To transmit infrared radiation across the lab with a pair of parabolic reflectors.

Information: This demonstration shows that infrared radiation can be collimated and focused by reflection. This could be the means behind a long-distance communication link, or a detector of heat-emitting bodies.

Two parabolic reflectors are set up facing each other across the lab. The infrared emitter is placed at the focus of one of the dishes and allowed to heat up for 10 minutes. One length of wire is strung taut, vertically, across the middle of the receiver dish. A second length of wire is strung horizontally across the middle. The place of intersection marks the centre of the dish and serves as a guide to finding the focus.

Two detectors are provided. One is a bead thermistor, which acts like a black-body thermometer. The other is a black disc with thermochromic paint.

Since the wire to the bead thermistor is stiff, if the wire is supported by a clamp stand the bead can be positioned anywhere within the dish. It can either be held steady, or scanned slowly from place to place. By this means it can be shown that the hottest spot is a minute region. The temperature is typically above 200°C.

The Nicholl Absorption Kit comprises a set of four metal disks each with thermochromic temperature indicators on one side. The reverse sides are finished differently in silver, brushed silver, lustrous black and matt black. The one with the matt black surface is held in its support by hand at the focus of the receiving dish. This should be about 3 cm from the point where the wires cross and between it and the dish. The temperature can be seen to rise to 70°C in under 60 s.

A match can be supported by a small blob of Blutac fastened to the junction of the wires. Let one quarter of the matchstick protrude outside the dish to counterweight the matchhead. We have been unable to ignite a match by this means.

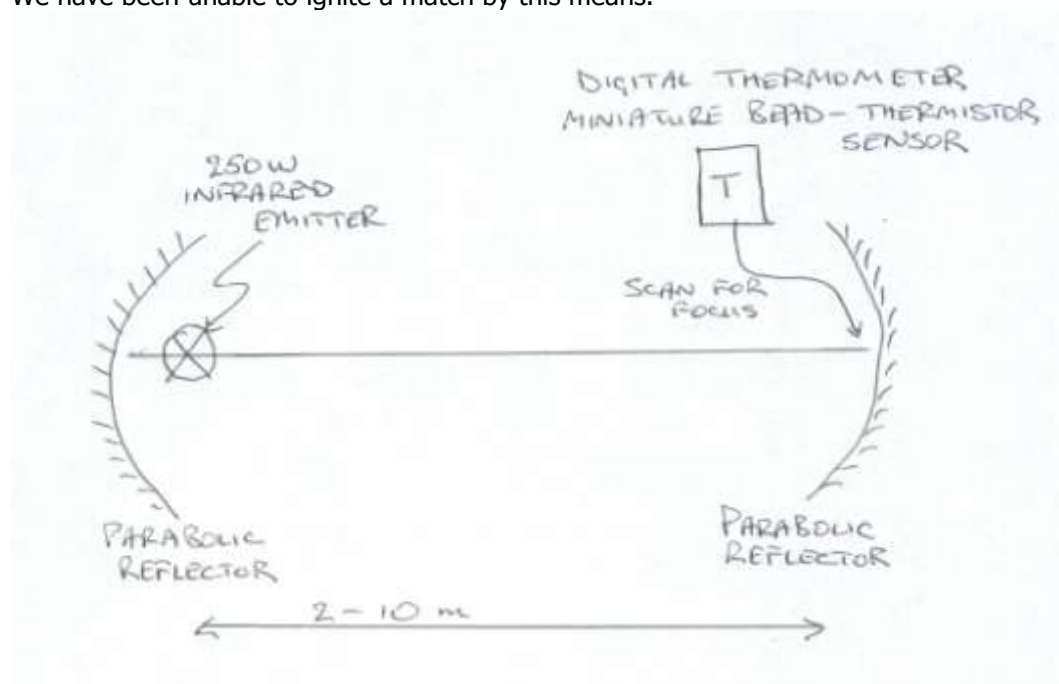

What you need: Infrared Emitter (230 V, 250 W, ES27 base (Pig lamp)), ES27 lampholder, 2 x Parabolic reflectors, Nicholl Absorption Kit, digital meter with bead-thermistor temperature sensor, wire (nichrome, about 36 SWG).

What to do:

1. The lamp should be set up horizontally at the focus of one of the parabolic dishes.
2. The lamp takes about 10 min to heat up fully. Therefore leave it running continuously.
3. Move the bead thermistor slowly around the spot where you expect the radiation to be focused. Search and locate the place where the intensity is greatest.
4. Carefully insert a finger in the region of the focus to get a tacit experience of the heating effect of a parabolic mirror.
5. Place the metal disk with a matt-black face in its holder (parts of the Nicholl Absorption Kit) and position the disk at the focus, its blackened face directed at the reflector. How long does it take to reach 70°C?
6. If you have time, compare the times taken by the other 3 disks to reach 70°C.

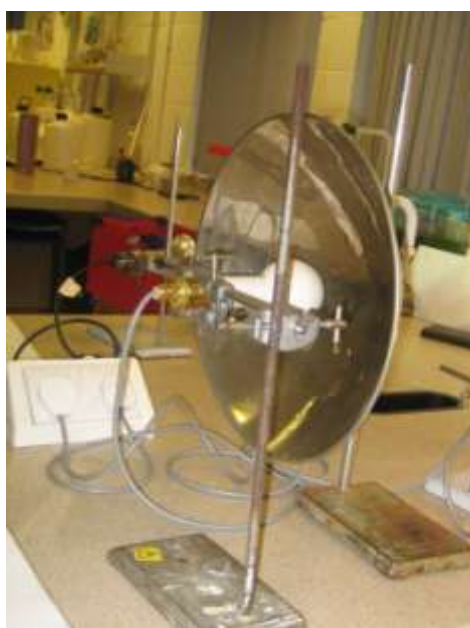
**Equipment:**

Infrared source: The source is a Quartz Heat Lamp (230 V, 250 W, ES27 base) from Commercial Lamp Supplies costing £17.63. It is sometimes known as a 'Pig Lamp' as it can be used to warm piggeries. The emissions are entirely invisible.

http://www.commercial-lamps.co.uk/acatalog/Quartz_heat_lamps.htm

Nicholl Absorption Kit: Product renamed 'Radiation Absorption Disc Set' from Timstar, product code HE43015, £29.50. Do not overheat the discs. They are easily damaged.

Safety: The lamp gets very hot and should not be touched. Because of the way we are using it in this experiment it would not be practicable to fit a wire cage around it to prevent it being touched. Therefore users must be given an oral warning of the risk.



Because of the lamp's high running temperature, the lampholder should be of a ceramic/metallic composite design. The lamp should not be operated pointing downwards, nor slanted downwards. In this application, the lamp faces horizontally.

Transmitter (TOP): Parabolic dish with quartz heat lamp at focus.

Receiver (BOTTOM): Parabolic dish with miniature temperature probe.

More to do: Show that heat radiation from a non-luminous source of heat can be reflected by a polished metal surface (look up Scheele in the Historical Account of Discoveries).

IRR: Visible indicator of infrared radiation

Purpose: To give a visual indication of infrared radiation from its suppression of phosphorescence.

Information: The special screen has been coated with a preparation of zinc sulphide and dopants (possibly silver). If irradiated with ultraviolet radiation the screen fluoresces and exhibits phosphorescence. The time delay for the phosphorescence to disappear is many minutes. If, while the screen is phosphorescing, having just been irradiated with UV, radiation from an infrared LED is swept swiftly across it, a dark track is left in its wake. In short, infrared stops zinc sulphide phosphorescing. This is a visual indicator of near-infrared radiation.

What you need: UV lamp, infrared LED source, zinc sulphide screen, 5 V supply.

What to do:

1. Briefly shine the ultraviolet lamp at the zinc sulphide screen.
2. Switch off the lamp and watch the screen phosphoresce.
3. Quickly sweep the infrared LED across the screen in an arc, holding the LED close to the surface. The sweep time should be about one second – no more.
4. What change results from this action? Express the phenomenon in your own words.

Equipment:

Zinc sulphide screens (either Leybold product 468 72 or Frederiksen product 3075.00) exhibit phosphorescence. They can be used to detect infrared as well as ultraviolet radiation (shown here). Zinc sulphide, in ordinary form, does not fluoresce. The form that does has been doped with silver and is hard to obtain as a lab reagent.

The hand-held UV lamp is Maplin product ZC10L. For a risk assessment, go to <http://www.sserc.org.uk/members/SafetyNet/bulls/208/Maplin%20UV%20lamp%20risk%20assmt.rtf>

Infrared LED: SFH409, 950 nm, Rapid (58-0400).
Pin ID: short leg = cathode.
Series resistor = 220 Ω , V = 5 V



Zinc sulphide screens:
Leybold, 468 72 (Left)
Frederiksen, 3075.00 (Right)

IRR: Wavelength sensitivity of a silicon photodiode

Purpose: To compare the efficacy of photodiodes with wavelength of radiation.

Information: If the large photodiode D1 is irradiated in turn by each of the 4 LEDs (all running at typical brightness) it will be seen that the reverse leakage current generated by the infrared LED is much greater than that from any of the visible LEDs. The maximum wavelength sensitivity of a photodiode is often in the near IR region.

(This is not a proper, quantitative comparison because we have not attempted to match the radiant power of the LED sources. All we set out to show is that a silicon PIN photodiode is a very effective detector of near-infrared radiation.)

What you need: Teaching Chip 3 (with array of photodiodes), JJM board, RGB LED sources, infrared LED source, multimeter, 5 V supply, 1 M Ω resistor, ambient radiation shield.

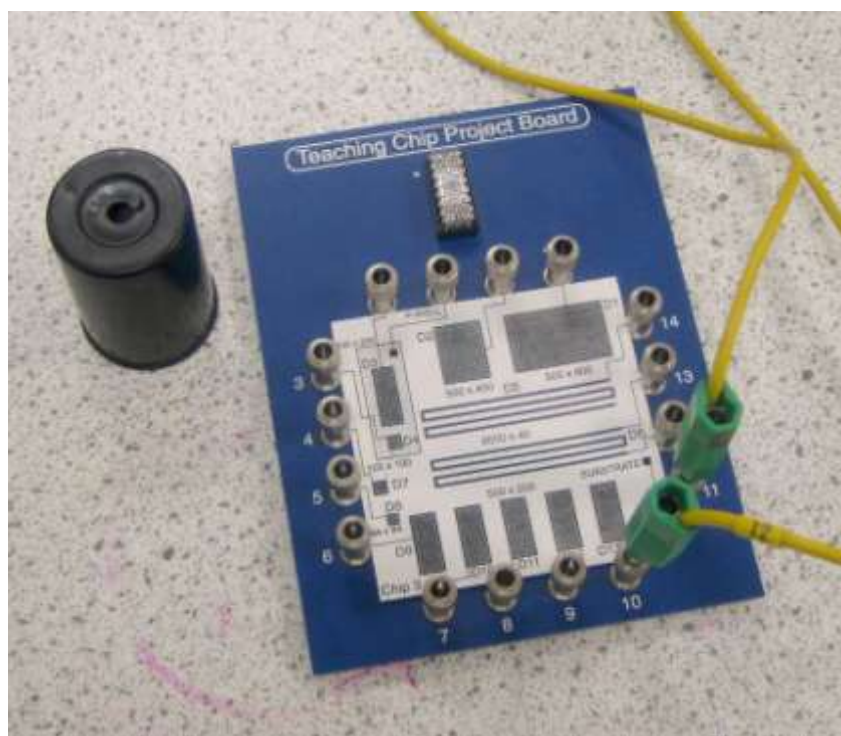

Teaching Chip 03 in the JJM board with 4 mm sockets. The cardboard overlay shows a plan of the structures on the integrated circuit. Each rectangular structure is a diode. Most are photodiodes. A 35 mm film canister shields ambient light.

What to do:

1. Fit the ambient radiation shield over the integrated circuit. It has a 5 mm hole in the lid to accept a LED.
2. Connect a 1 M Ω resistor in series with photodiode D1. Reverse bias with a voltage of between 1.5 V and 6 V. (The photodiode is being operated in its photoconductive mode.)
3. Set the multimeter to read voltage on its 200 mV setting. Connect it across the 1 M Ω resistor. A reading of 1 mV represents a leakage (or photo-) current of 1 nA.
4. Irradiate D1 in turn by the red, green, blue and infrared sources. Make a note of the readings and compare.
5. **QUESTIONS:** Does the photodiode detect infrared radiation? Which type of radiation results in the greatest photocurrent?

Equipment:

The integrated circuit is one of a set of four designed by the Department of Electronic Engineering at the University of Edinburgh. The set is known as the 'Teaching Chips'. Each IC is sold separately at £2. SSERC can supply them. Chip 3 has an array of photodiodes, many with different properties, letting you find out how the electrical performance depends

on physical properties. D1 is a planar photodiode. The top layer is p-type silicon; the substrate is n-type. The top p-type layer is the anode; it connects to pin 15. The substrate is the cathode; it connects to pin 11. To use the photodiode in its photoconductive mode, pin 15 should be biased negatively.

The JJM Project Board provides an easy means for operating one of the Teaching Chips with 4 mm connectors. There is an extensive set of cards for placing in the centre of the board. Some cards show the semiconductor structures, either in plan or section. Others show the electrical drawing symbols.

Infrared LED: SFH409, 950 nm, Rapid (58-0400). Pin ID: short leg = cathode. Series resistor = 220Ω , $V = 5 \text{ V}$

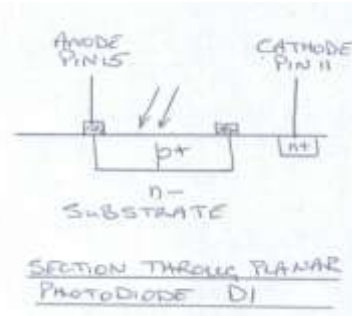
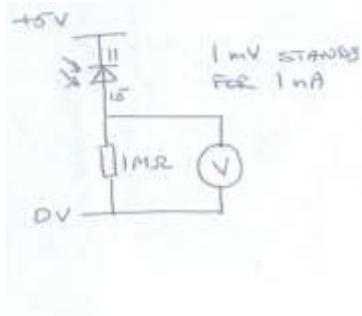

LEFT:
Wiring diagram for photodiode D1.

RIGHT:
Section through photodiode D1.

IRR: Photodiode area

Purpose: To compare the dependence of the photocurrent on photodiode area.

Information: The integrated circuit (Chip 3) has an array of photodiodes, three of which (D1, D2 and D13) have different surface areas but otherwise similar properties. The areas vary as the ratio 4:2:1. The photodiodes on Chip 3 are irradiated with diffuse infrared radiation. The diffuser is LSD to ensure that uniform radiation falls on the photodiodes. A blackout canister should be fitted over Chip 3 to shield the photodiodes from daylight.

What you need: Teaching Chip 3 (with array of photodiodes), JJM board, infrared LED source, multimeter, 5 V supply, 1 M Ω resistor, ambient radiation shield, LSD (10° circular).

What to do:

1. Fit the ambient radiation shield over the integrated circuit. It has a 5 mm hole in the lid to accept a LED.
2. Connect a 1 M Ω resistor in series with photodiode D1. Reverse bias with a voltage of between 1.5 V and 6 V. (The photodiode is being operated in its photoconductive mode.)
3. Set the multimeter to read voltage on its 200 mV setting. Connect it across the 1 M Ω resistor. A reading of 1 mV represents a leakage (or photo-) current of 1 nA.
4. Irradiate the photodiodes D1, D2 and D13 in turn with the infrared source. Make a note of the readings and compare.
5. **QUESTIONS:** How does the photocurrent depend on surface area?

Equipment:

The integrated circuit is one of a set of four designed by the Department of Electronic Engineering at the University of Edinburgh. The set is known as the 'Teaching Chips'. Each IC is sold separately at £2. SSERC can supply them. Chip 3 has an array of photodiodes, many with different properties, letting you find out how the electrical performance depends on physical properties. D1, D2 and D13 are all planar photodiodes. The top layer is p-type silicon; the substrate is n-type. The top p-type layer is the anode; it connects to pins 15 (D1), 16 (D2) and 10 (D13). The substrate is the cathode; it connects to pin 11. To use one of the photodiodes in its photoconductive mode, the anode should be biased negatively.

The JJM board provides an easy means for operating one of the Teaching Chips with 4 mm connectors. There is an extensive set of cards for placing in the centre of the board. Some cards show the semiconductor structures, either in plan or section. Others show the electrical drawing symbols.

Diode	Length (μm)	Width (μm)	Anode pin	Cathode pin
D1	800	500	15	11
D2	500	400	16	11
D13	500	200	10	11

Infrared LED: SFH409, 950 nm, Rapid (58-0400). Pin ID: short leg = cathode. Series resistor = 220 Ω , V = 5 V

AH investigations: The dependence on area can be further looked at by wiring up photodiodes in parallel (effectively you are just adding one area to another). There are, in total, seven photodiodes of similar structure. The resulting number of combinations is rather great. The wavelength sensitivity can also be investigated.

IRR: Linearity of photodiode's response

Purpose: To check on the linearity of a photodiode's response to infrared radiation.

Information: Linearity is checked by the 'two-lamp method'. If using a photodiode with daylight-blocking filter the demo can be done in shaded daylight. Set up two IR LEDs side by side directed at the photodiode through LSD to diffuse the radiation. Switch on one LED, then the other, and then both. If the sum of the photocurrents from the individual LEDs equals the photocurrent from the two together, this is an indication that the response may be linear. By stepping up the voltage, you can keep repeating this check across several orders of magnitude of intensity and current.

The detector is a photodiode, BPW41N, chosen because it should have a linear transfer function between irradiance and photocurrent. The photocurrent develops a voltage across the series resistor. The voltage is directly proportional to the photocurrent. You measure voltage in this experiment.

This experiment is a desirable precursor to an inverse-square-law experiment trying to show that the law holds true.

What you need: IR LED (x2) (independently switched), IR photodiode, LSD (10° circular), multimeter, canister to shield ambient light, LV supply (variable voltage, voltage-regulated)

What to do:

1. Switch on LED A at 4 V; note meter reading; switch off.
2. Switch on LED B at same voltage; note reading.
3. Calculate the sum of A and B.
4. Switch on both A and B LEDs at same voltage; note reading. Does the reading equal the sum of (A + B)?
5. Step up the supply voltage to 5 V and repeat the process.
6. Step up the supply voltage to 6 V and repeat the process.
7. What conclusion do you come to?

Equipment:

IR Photodiode: BPW41N, Rapid Electronics 58-0115 (68p). Series resistor = 10 k Ω .

Supply = 5 V.

Infrared LED: SFH409, 950 nm, Rapid (58-0400) (40p). Pin ID: short leg = cathode. Series resistor = 220 Ω , V = 5 V.

The black-out canister is an empty small-sized tin of beans, painted matt black, with lid detached. The photodiode has been placed at the centre of the base pointing up. The two LEDs have been mounted at the centre of the lid pointing down. They are about 6 mm apart. A sheet of LSD has been placed directly in front of the LEDs to produce a uniform diffuse irradiation on the photodiode. The separation between the LEDs and photodiode is about 30 mm. The switches that operate the LEDs are on an external circuit board.

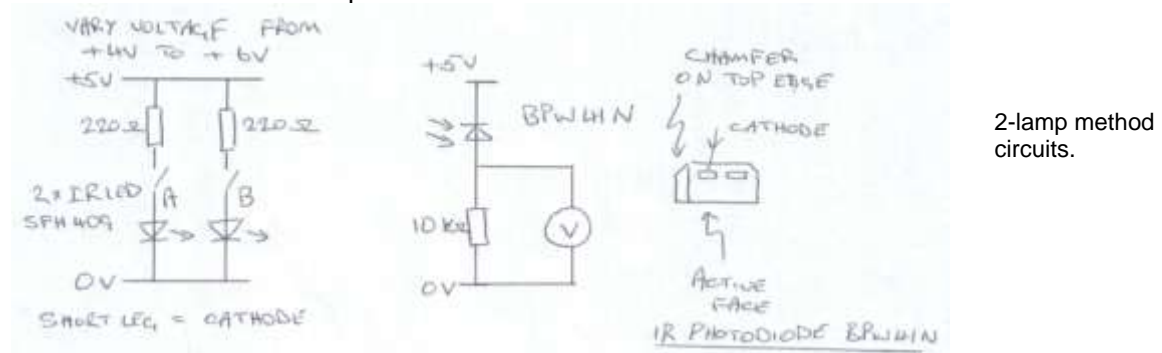

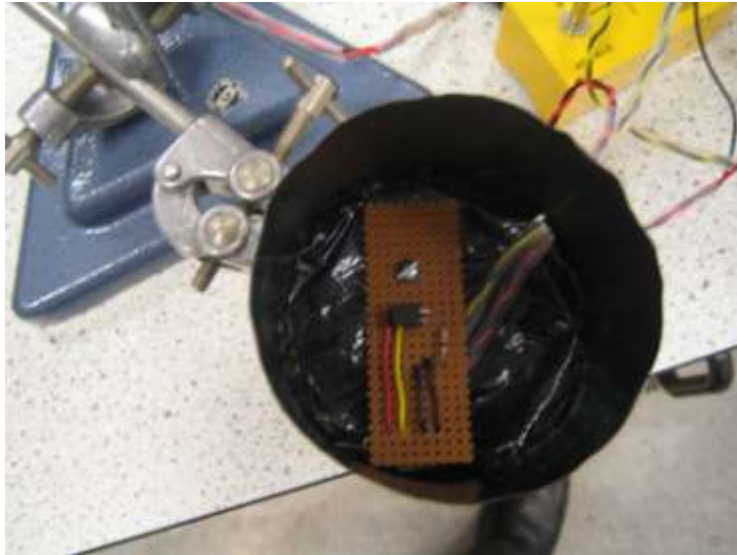

Photodiode mounted near middle of canister base, pointing up.



Two LEDs mounted 6 mm apart behind light-shaping diffuser on canister lid.



Two-lamp method apparatus.

IRR: Inverse square law

Purpose: To show that the dependence of intensity with distance is an inverse-square relationship with infrared radiation.

Information: Obtain a point source by placing a piece of circular LSD and small-diameter circular aperture hard up against an infrared LED. The small aperture reduces the size of the source and removes radiation directed obliquely away from the principle axis of the experiment. The LSD diffuses the radiation, removing irregularities caused by the crudeness of the LED's lens.

The detector is a photodiode, BPW41N, chosen because it should have a linear transfer function between irradiance and photocurrent. The photocurrent develops a voltage across the series resistor. The voltage is directly proportional to the photocurrent. You measure voltage in this experiment.

To prevent specular reflections off the bench the source and detector should be at least 4 cm above the surface for an experimental range of 40 cm.

What you need: IR LED, IR photodiode, metre stick, multimeter, LSD (10° circular) aperture (1 mm dia.).

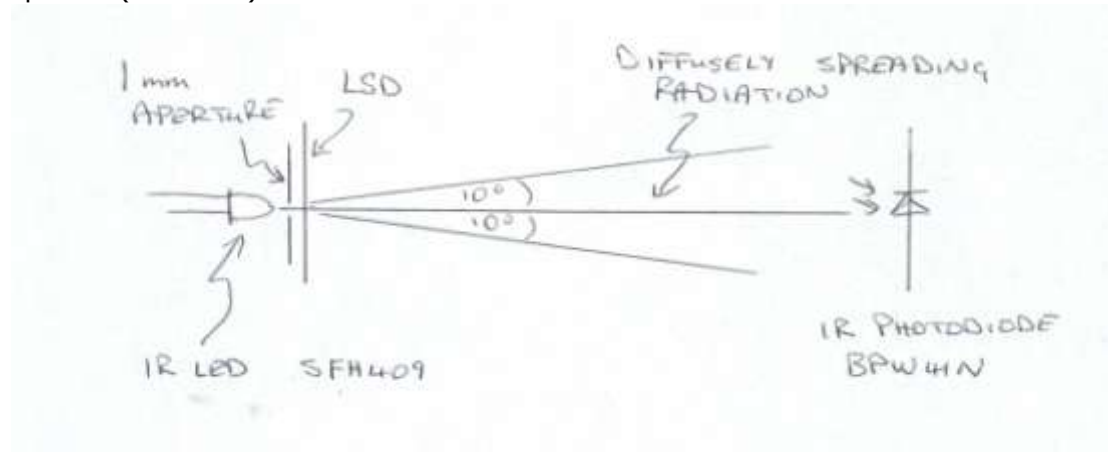
**What to do:**

7. Place a 1 mm diameter aperture hard up against the centre of the infrared LED. Place a sheet of LSD hard up against the aperture. The LSD acts as a 1 mm diameter source irradiating space with a 10° cone of radiation.
8. Set up the photodiode on the optical axis of the LED at a distance of 10 cm.
9. Obtain an ordered set of readings of voltage against distance between 10 cm and 40 cm.
10. Analyse the data by means of a log-log plot. Is the gradient -2.0?

Equipment:

IR Photodiode: BPW41N, Rapid Electronics 58-0115 (68p). Series resistor = 10 kΩ.

Supply = 5 V.

Infrared LED: SFH409, 950 nm, Rapid (58-0400) (40p). Pin ID: short leg = cathode. Series resistor = 220 Ω, V = 5 V.

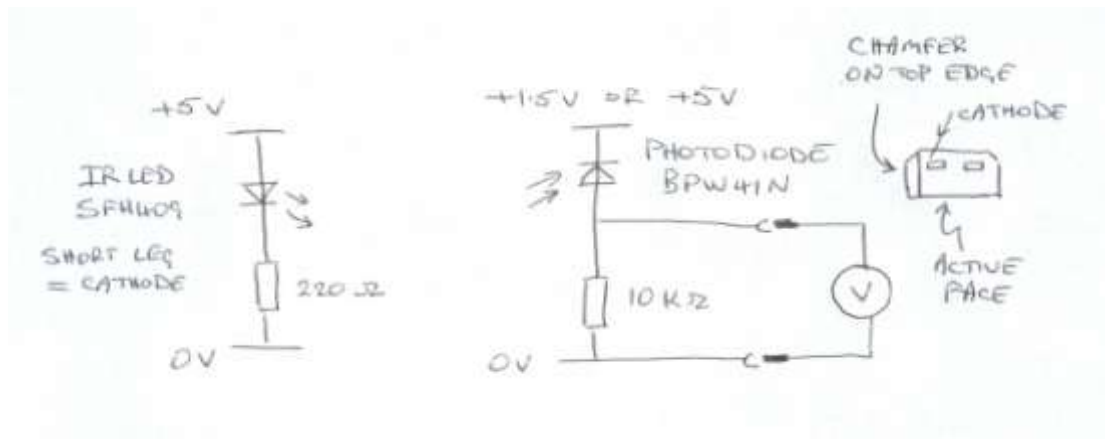

Circuit Diagrams (above): Infrared emitter, IR-LED SFH409; infrared receiver, IR-photodiode BPW41N.

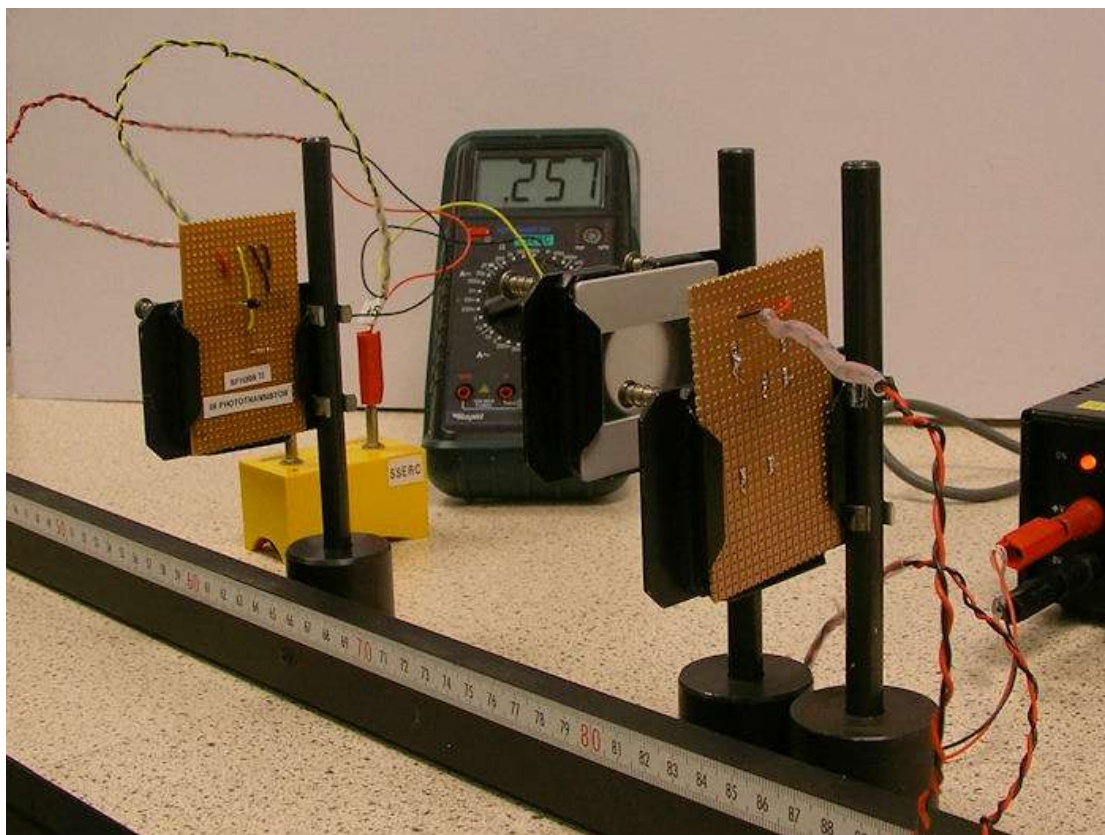

Photograph (above): Apparatus for showing the inverse square law with infrared radiation. The detector illustrated on the LHS is an SFH309 phototransistor – not the device we recommend in the text (BPW41N). The emitter is on the reverse side of the circuit board at the RHS of the photograph. The LSD, in a 35 mm slide mount, is directly in front of the emitter.

IRR: To transmit chopped IRR across the lab with lenses.

Purpose: To transmit chopped infrared radiation across the lab with lenses.

Information: Radiation can be chopped mechanically by mounting an IR LED on the enclosure of a small motor on whose spindle there is a slotted disk. Alternatively it can be chopped (or pulsed) electronically by driving it from a function generator or signal generator.

The radiation should be collimated, or focused, with one lens ($f = 50$ mm) and collected with a second lens ($f = 150$ mm) to focus on the photodiode. Otherwise it should be transmitted through an optical fibre. (The setting up with lenses is rather enjoyable. This is a nice mixed-technology activity.)

The chopped radiation is picked up with a photodiode and displayed on a CRO. The speed of response of the detector is found. (Actually it is the speed of response of the whole system. The photodiode is only one part of it.)

The initial signal should have a frequency of about 1 kHz and peak to peak voltage of about 3 V.

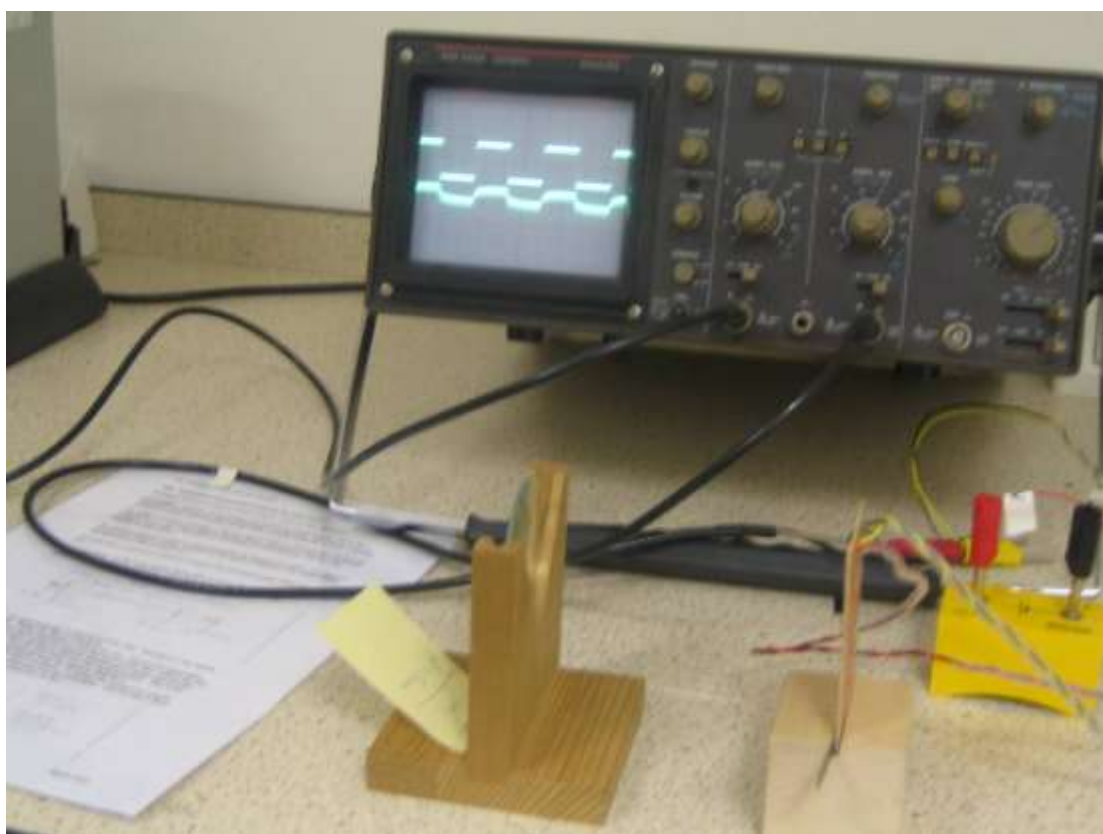

FOREGROUND: Lens L2 focusing radiation on IR photodiode.

BACKGROUND: (Top trace) Signal generator output; (Bottom trace) Transmitted signal.

What you need: IR LED, motor (small), slotted disk, 2 x lenses (dia. = 50 mm, focal lengths 50 and 150 mm), IR photodiode, optical fibre, function or signal generator, oscilloscope (dual channel), 1.5 V cell.

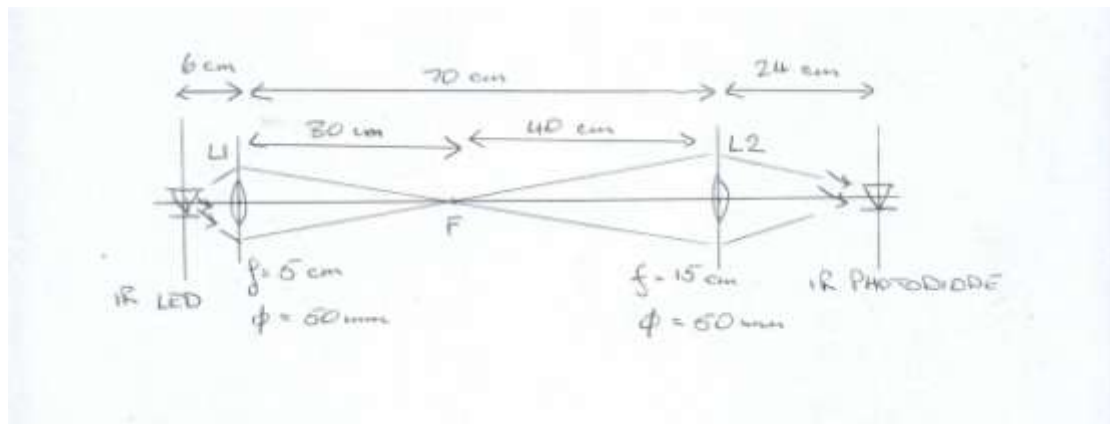
**What to do:**

1. Connect the signal generator to Channel A of the CRO. Generate a 1 kHz square-wave signal. Trigger the CRO on Channel A.
2. Temporarily set up the photodiode in front of the LED. Connect the signal taken from across the series resistor and apply to Channel B on the CRO. Adjust the CRO so that the signal from the infrared detector (photodiode) is clearly seen and sits directly beneath the square-wave output from the signal generator. That is the signal on Channel B sits directly below the signal on Channel A.
3. Set up the two lenses L1 and L2 as shown. L1 collects the chopped (or pulsed) infrared radiation at F and refocuses it on the photodiode. This can take a bit of adjusting. Once you get the hang of it, it's fun.

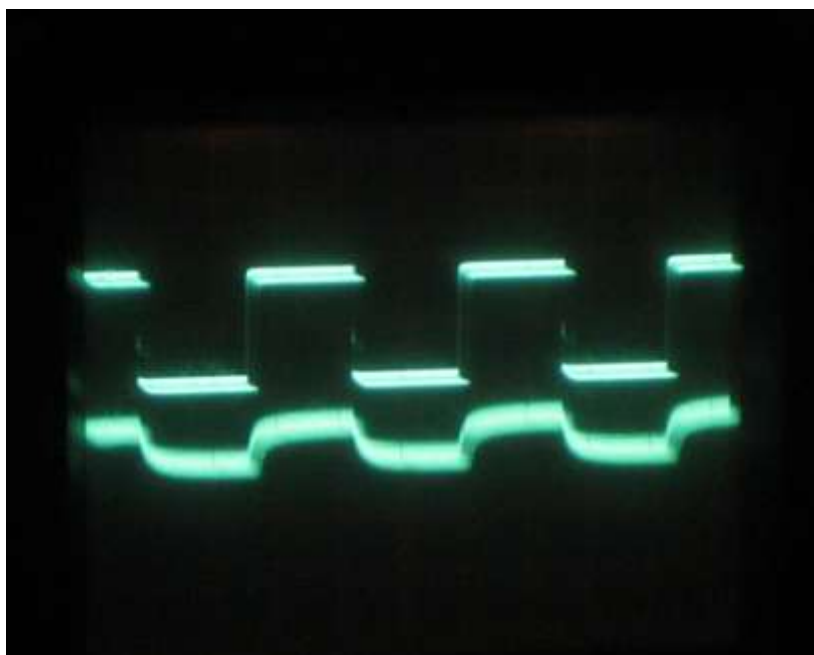
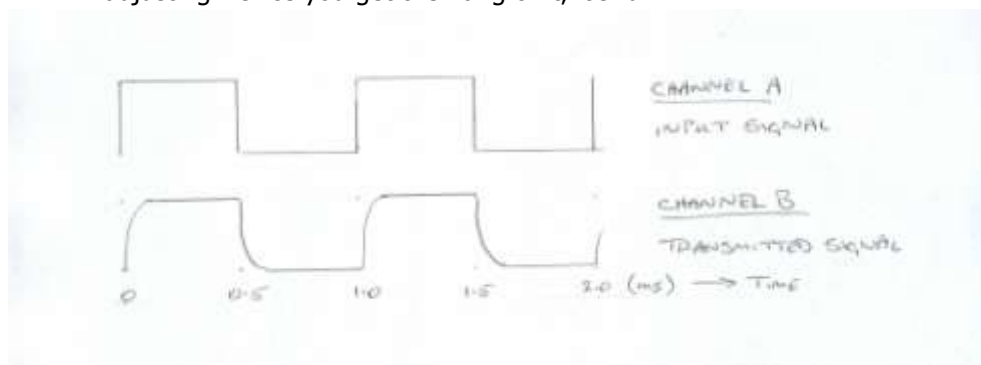

CRO screenshot:
 Top image: Square wave 1 kHz output from the signal generator (3 V pk-pk).
 Bottom trace: Signal picked up by the infrared detector ($R=10\text{ k}\Omega$, 300 mV pk-pk).

Equipment:

IR Photodiode: BPW41N, Rapid Electronics 58-0115 (68p). Series resistor = 10 kΩ.

Supply = 1.5 V.

(The value of the series resistor R (10 kΩ) can be lowered to 1.0 kΩ to reduce the RC time delay of the detector for a fast response. But the drawback is that the voltage dropped across R is also low. If you find that the voltage is too low for your liking, replace the 1 kΩ resistor with another at 10 kΩ. The output voltage will be ten times greater. The size of the photocurrent just depends on the irradiation.)

Infrared LED: SFH409, 950 nm, Rapid (58-0400) (40p). Pin ID: short leg = cathode. Series resistor = 220 Ω, $V = 5$ V.

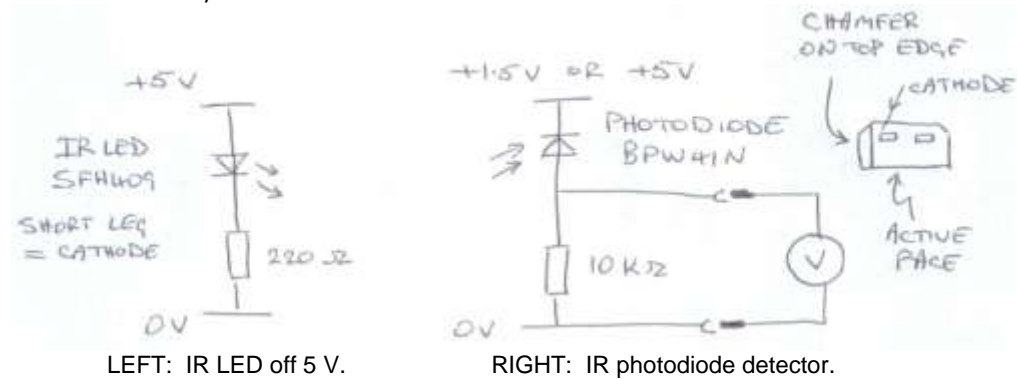

If driving a LED with a function generator sink the LED rather than source it. That is to say, connect the LED's cathode to the signal output and its anode, through a 220 Ω series resistor, to an external +5 V supply and common the grounds.

If driving a LED with a signal generator, connect the anode to the high impedance output through a 330 Ω series resistor. Also connect a signal diode (1N4148), reverse biased, in parallel across the LED. The LED's cathode and signal-diode's anode should be connected to ground.

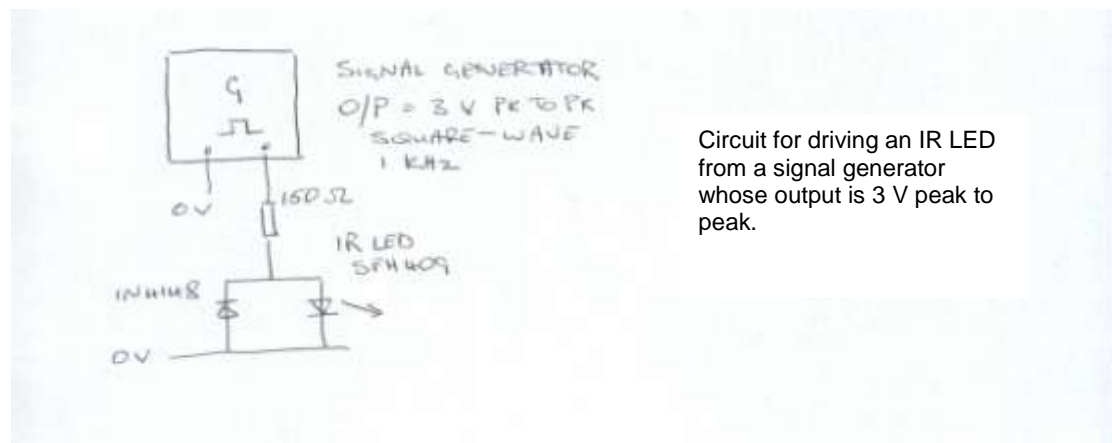

AH investigation: What limits the speed of response?

IRR: Infrared remote controller

Purpose: To pick up the emissions from an infrared remote controller with a photodiode, display the signals on a storage oscilloscope and analyse the signals.

Information: The infrared remote controller (PAC 1209) emits bursts of signals (or wavetrains) of a frequency of about 38 kHz. The number of cycles (or waves) per wavetrain is about 11. The period at which the wavetrains occur is either about 1.09 ms or 2.13 ms, signifying logic 0 or 1 respectively (or the converse). These signals are picked up by a photodiode and captured on a digital storage oscilloscope (the Picoscope).

Each button-press is coded as a unique sequence of wavetrains (or pulses) so that the signal receiver (in the TV set) can distinguish between them. The Infrared Signal Receiver Kit (SEP 041) shows this. Pressing different buttons on the remote control causes different LEDs on the signal receiver to light up.

The suggested teaching order is (1) note the action that different key-presses on the remote control have on the signal receiver; and (2) pick up, display and analyse the signals from the remote control with a photodiode and Picoscope.

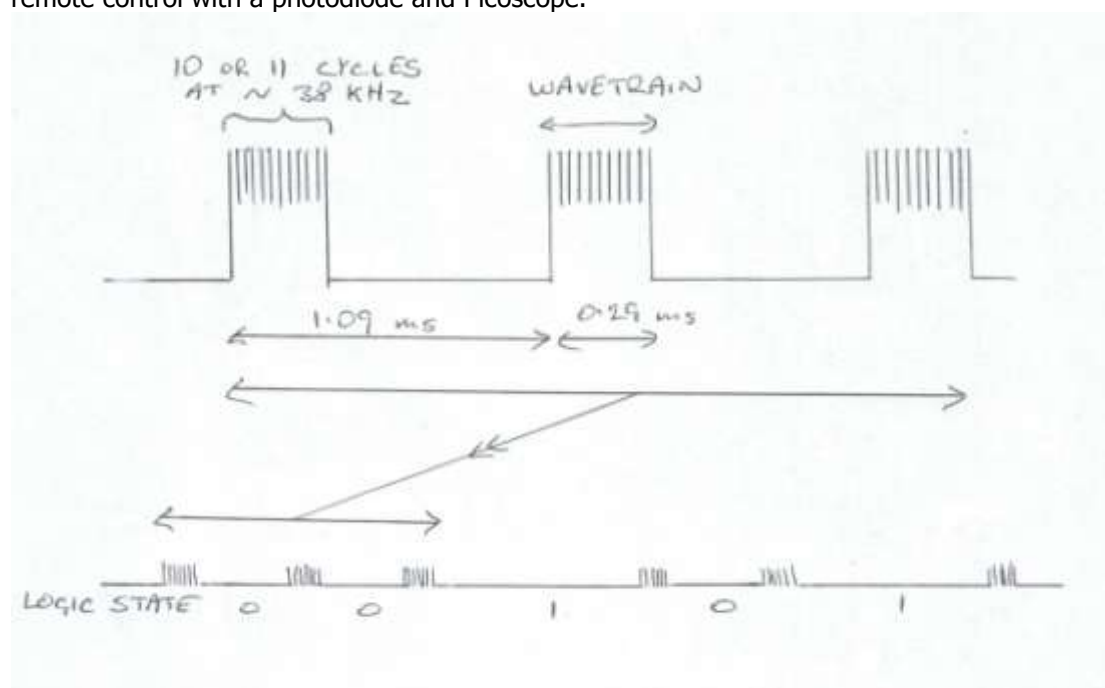

What you need: Infrared remote controller (PAC 1209), Infrared signal receiver kit (SEP 041), IR photodiode, IR filter, Picoscope, Laptop.

What to do:

1. Note the action that different key-presses on the remote control have on the signal receiver.
2. Pick up, display and analyse the signals from the remote control with a photodiode and Picoscope.

Equipment:

IR Photodiode: BPW41N, Rapid Electronics 58-0115 (68p). Series resistor = 10 k Ω .

Supply = 5 V.

Infrared remote controller (SEP, PAC 1209).

Infrared signal receiver kit (SEP 041).

Picoscope, 2203.

IRR: Thermopile

Purpose: To investigate the thermopile, finding out how it works and what its use is.

Information: Whereas most the earlier infrared experiments were with infrared LEDs emitting near-infrared radiation between 700 and 1500 nm, in this and further experiments you will be working with far-infrared radiation, sometimes called *heat radiation*.

The IR emissions from our hot-body source are detected by the thermopile, but not by the photodiode. This should be shown.

A *thermocouple* consists of 2 wires of dissimilar metals joined together to complete a circuit. It generates electricity when there is a temperature difference between its two junctions (B165). The thermocouple emf is a function of the temperature difference and types of material. Place the thermocouple probe on the heater's wire cage, measure the thermocouple voltage and derive the temperature from the look-up table.

A *thermopile* is just lots of thermocouples in series. It is highly sensitive to any radiation with a heating effect across the optical spectrum from ultraviolet, through visible into long-wave infrared, measuring the irradiation in W/m^2 . It can be used for quantitative experiments such as the inverse square law, Stefan's Law, etc., or measuring the irradiation from the Sun.

The *Heat Absorbing Glass* does just that. It blocks long-wave infrared radiation and warms up.

The *Hot Mirror* has a multi-layer dielectric coating to reflect harmful infrared radiation (heat), while transmitting visible light. It is applied mainly in projection and illumination systems.

The *Heat Radiation Plate* is silvered on one side and matt blackened on the other. Place it on top of the radiant heater to warm up then hold it in view of the thermopile, flipping it from black to silver to show that the emissivity of the black surface is greater than that of the silver one.

What you need: Radiant Heater, thermopile, thermocouple wire, microvoltmeter, IR photodiode, multimeter, Heat Radiation Plate, hot mirror, heat-absorbing glass.

What to do:

1. Place one junction of the thermocouple on top of the radiant heater (it does not matter if it touches) and measure the thermocouple voltage. Estimate the temperature from the look-up table, or calculate it from its nominal sensitivity of $40 \mu\text{V}/^\circ\text{C}$.
2. A thermopile is a series of thermocouples interconnected between its open blackened front-plate, which is irradiated from the radiant heater, and a shaded thermal mass at the rear.
3. Compare the readings from the thermopile at 25 and 50 cm.
4. Warm the Heat Radiation Plate by holding it above the radiant heater for 20 s. Remove from the heat and use the thermopile to measure the heat being emitted from its opposite faces.
5. Hold the heat-absorbing glass in front of the thermopile. By what fraction does the reading fall? Does the glass get hot?
6. Hold the hot mirror in front of the thermopile. By what fraction does the reading fall? Does the mirror get hot?
7. Direct the thermopile away from the radiant heater. Use the hot mirror to reflect heat at the thermopile.
8. Does the IR photodiode detect radiation from the radiant heater?

Equipment:

Specialised equipment in this experiment includes:

- Radiant Heater, Electrosond, 230 V, 400 W
- Thermopile, Frederiksen, 2872-81
- Heat Radiation Plate, Frederiksen, 2700-00
- Hot Mirror, Edmund Optics, 25x25 mm, NT43-843 (transmits visible, reflects IR)
- Heat Absorbing Glass, Edmund Optics, 102x127 mm, NT04-009 (transmits visible, absorbs IR)
- Thermocouple, Type K materials: chromel and alumel, SSERC.



EI

Electrosond Radiant Heater, 230 V,
400 W



Frederiksen Thermopile, 2872-81.

IRR: Inverse square law with heat radiation

Purpose: To show that the dependence of intensity with distance is an inverse-square relationship with infrared heat radiation.



Information: The method is to expose a black-bulb thermometer in a radiant heat flux, noting the time taken for its temperature to rise by a set span at different distances from the source of radiation. Time is assumed to be inversely proportional to the rate of heating (B195).

The thermometer should be readable to about 0.1°C and have a range which includes room temperature. The range should lie between about 15°C and 30°C .

The bulb should be rested in a dry ice bath until its temperature is about 2.0°C below that of the room. A stop-watch is started when the reading is 1.5°C below room temperature and stopped when 1.5°C above.

What you need: Radiant Heater, thermometer (black-bulb, high sensitivity), ice bath, timer, metre stick.

What to do:

1. Take ordered pairs of readings of the time taken for the black-bulb thermometer to rise by 3.0°C at distances of 10 cm to 80 cm from the radiant heater. Times should be measured to 0.1 s.
2. Analyse the data, checking for proportionality between time and distance squared. Finding it is evidence of an inverse-square relationship between heat radiation and distance.

Equipment:

Radiant heater, 230 V, either 250 W, 300 W or 400 W. Suppliers include:

- Electrosound, Radiant Heater, 230 V, 400 W
- Nicholl, Radiant Heater, 230 V, 300 W
- Quartz Heat Lamp (230 V, 250 W, ES27 base) from Commercial Lamp Supplies costing £17.63. It is sometimes known as a 'Pig Lamp' as it can be used to warm piggeries. The emissions are entirely invisible. http://www.commercial-lamps.co.uk/acatalog/Quartz_heat_lamps.htm

IRR: Non-contact temperature sensor

Purpose: To use a non-contact temperature sensor.

Information: The method of operation of this non-contact thermometer from SEP has not been specified. We suspect that it is a pyroelectric infrared (PIR) device, but, not knowing, we just call it a 'non-contact' temperature detector.

Pyroelectricity is the generation of electric charge when the pyroelectric material changes temperature, up or down. It is a transient effect. Once the temperature stabilizes the charge dissipates. Some pyroelectric materials are highly sensitive to the heating effects of long-wave infrared radiation, such as might be emitted by a person. For this reason they are in widespread use in intruder alarms, where they are known as PIR detectors.

When the non-contact temperature sensor is held at about 1 cm from a surface it purports to measure the temperature of the surface.

The *Peltier effect* is a type of thermoelectricity, being the converse of a thermocouple. If you have an electric circuit in which the conductors in one part are of a different material from the ones in the other part and a voltage is applied from an external energy source, the resulting current through the circuit causes heat to be evolved at the upper junction and heat to be absorbed at the lower junction. Thus a Peltier device can be used as a heater or cooler.

What you need: Non-contact temperature sensor, Peltier effect device, thermometer (liquid-in-glass), kettle, beaker, radiation can (half-black, half-silver), (x2) bead thermistors.

What to do:

1. Half fill the beaker with hot water and measure its temperature with the liquid-in-glass thermometer, stirring well. Now direct the pyroelectric temperature sensor at (1) the glass flask (side wall), and (2) the water (top surface). Account for what you find.
2. Fill the radiation can with hot water and measure the temperature of its black and silver surfaces with your non-contact detector. The radiation can has two miniature bead thermistors fixed to its opposite faces. These also measure surface temperatures. Account for what you find.
3. Switch on the LV supply to energize the Peltier effect device. Use the temperature sensor to measure the temperature of its opposite sides.

Equipment:

Non-contact temperature sensor: SEP (161-300).

Also DJB supply an Infrared Thermometer (CS-1010.00) at £20.20.

Peltier effect device: SEP (161-353).

Miniature bead thermistor: R-T curve-matched (3 k Ω at 25°C), RS (151-215), £2.11.

<http://uk.rs-online.com/web/search/searchBrowseAction.html?method=searchProducts&searchTerm=151-215&x=25&y=13>



Non-contact temperature sensor: SEP (161-300).

IRR: Radiant efficiency of lamp

Purpose: To measure the radiant efficiency of a tungsten filament lamp.

Information: The Apparatus for Light Energy consists of a transparent plastic flask with a low-voltage light bulb and high-power resistor. When the flask is filled with water to the top of the bulb, the water can be heated either by longwave infrared emissions from the lamp or joule heating from the resistor. Radiant efficiency is found by comparing the heating effects of these two sources. It is assumed that nearly all of the visible radiation is transmitted through the water and flask wall.

To reduce the effects of heat loss to the surroundings, or heat intake from the surroundings, the water temperature should be about 1°C below room temperature before heating. Also the temperature rise should not exceed a few degrees.

Because of the many measurements and calculations, and knowing that the accuracy of the result also depends on experimental technique, this experiment is an excellent training exercise in measurement uncertainty, perhaps at the beginning of the Advanced Higher.

What you need: Apparatus for Light Energy, thermometer, (x2) multimeter (true rms-reading), LV supply (variable-voltage), balance, aluminium foil.

What to do:

1. Measure room temperature and let the starting temperature be 1.0°C lower.
2. Find by trial and error the supply voltage that delivers the same value of current to the bulb and resistor. (The value is a little over 4 A.) The value should be recorded to 0.01 A. In all subsequent runs the current must be adjusted to this value exactly.
3. Resistive heating: Empty and dry the apparatus. Place it on the balance and fill with water to the top of the bulb. Record the mass of water. Stir the water and measure its temperature. Connect the power supply to the resistor and switch on for 2 min 00.0 s exactly. Stir the water and re-measure the temperature.
4. Infrared Radiant heating: Empty and dry the apparatus. Place it on the balance and fill with water to the same as before. Stir the water and measure its temperature. Connect the power supply to the lamp and switch on for 2 min 00.0 s exactly. Stir the water and re-measure the temperature.
5. Total Radiant heating: Empty and dry the apparatus. Place it on the balance and fill with water to the same as before. Stir the water and measure its temperature. Cover the apparatus with aluminium foil. Connect the power supply to the lamp and switch on for 2 min 00.0 s exactly. Stir the water and re-measure the temperature.
6. Calculate the percentage loss of energy as radiation.

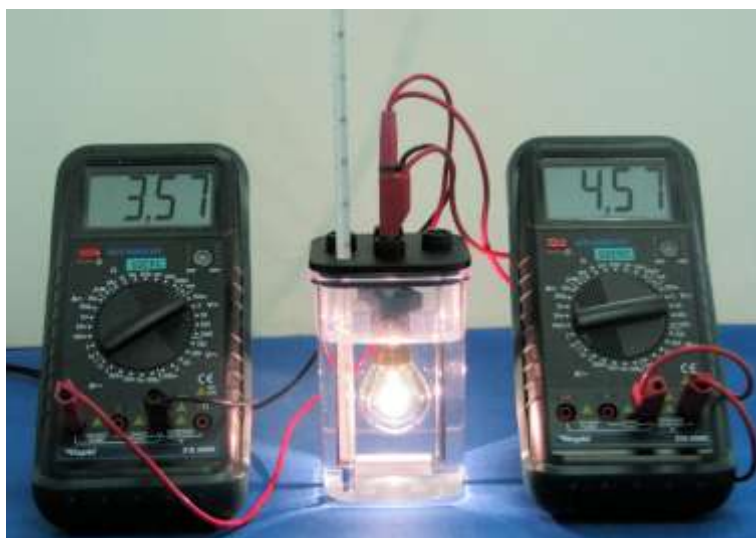
**Equipment:**

The Apparatus for Light Energy is Frederiksen product 3207.00. A UK supplier is Timstar,

IRR: Heat absorption by black or silver surface

Purpose: To compare the absorptivity of black and silver surfaces.

Information: An electric heater is made by winding nichrome wire round one rod of a pipeclay triangle, holding the element vertical in a clamp stand and energizing until it glows red hot. Two metal cans with equal volumes of water are positioned on either side. One can is silvered on the outside. The other is matt black. The cans are allowed to warm up for 5 min, the supply is switched off and the maximum temperature noted. The black can warms up appreciably faster.



DIY Radiant Heat Source mounted vertically between black and silver cans.

This is an experiment where the children can be asked to make their own heaters. They then have the satisfaction and thrill of seeing them glow red-hot.

From test runs the expected temperature rise of the blackened can is nearly 6°C . To minimize heat intake or loss from or to the surroundings, fill the cans with water at 3°C below room temperature. The power supply should deliver about 8 A at 12 V.

What you need: Nichrome wire (24 SWG, 40 cm), pipeclay triangle, (x2) radiation cans (black and silver), (x2) thermometers, multimeter, LV supply (8 A, 12 V), (x2) croc clips, beaker (about 500 ml), balance, stop-clock.

What to do:

1. Measure room temperature. Fill the beaker with water from the hot and cold taps, getting the temperature at 3°C below room temperature.
2. Fill both radiation cans with equal amounts of water. Use the balance to do this. The nominal mass, per beaker, is 160 g.
3. Set up the radiation cans, as shown, on either side of the heating element, using a pencil to get the air gaps equal.
4. After stirring well, measure the water temperatures in both cans.
5. Switch on the power supply and stop-clock.
6. After 5 minutes, switch off the power supply.
7. Stir the water in both cans and record the highest temperatures reached. There is a lag before the maxima are attained.

AH investigations:

1. Derive by theory the fraction of the radiant output that hits the surface of a radiation can. Hence work out the surface's absorptivity.
2. Because our radiation can is cylindrical, some the heat radiation may be reflected where the angle of incidence is large. Compare the relative absorptivities of cans which are circular and rectangular in cross-section.

Equipment:

A heater element can be made by wrapping about 25-30 cm of 24 SWG nichrome wire around one rod of a pipeclay triangle. The turns should be tight and neat, but not touching, nor overlapping. There should be about 6 cm extra nichrome wire at both ends of the heating coil to secure by a single turn around an adjacent pipeclay rod for better mechanical holding. The overall length of nichrome wire needed is about 40 cm, but perhaps no more than 30 cm conducts the current. Contact with flexible copper leads can be made with croc clips. The power supply is 12 V ac, delivering about 7-8 A. The nominal radiant power is 100 W. The pipeclay orientation should be vertical, letting two radiation cans to be irradiated simultaneously.

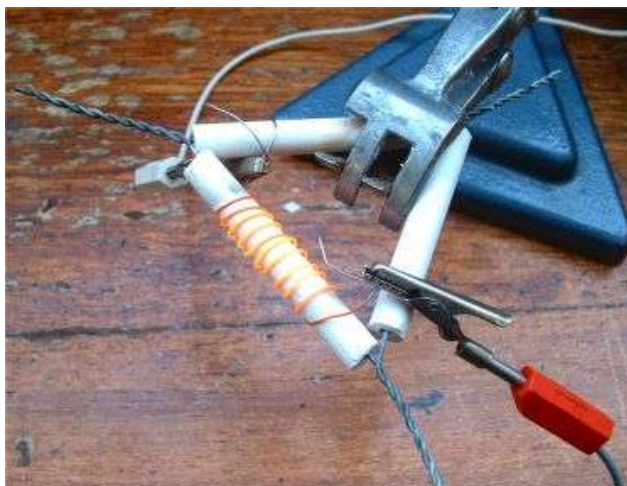

DIY heating element.

Radiation Cans: TD-8570A, PASCO (illustrated). Also DJB supply Radiation Cans (CS-2740.00) at £23.60.

Other suitable vessels are 150 ml, used, drinks' cans, such as ones that had held Schweppes' tonic water, painting one matt-black and covering the other with aluminium foil. The recess in the base provides insulation.

IRR: Focusing heat radiation

Purpose: To find if heat radiation can be focused with a flask of water, or a lens, thus charring or igniting paper.

Information: Set up the flask of water in the radiation and position the paper where the light is focused. Leave until it discolours. (Unless the sun comes out you are unlikely to char paper with the radiant-heat sources available.)

In direct sunlight, or other collimated radiation, the focus is about one flask-radius behind the spherical flask.

What you need: Infrared reflector lamp, flask (round), converging lens (large diameter, about 75 mm), Heat Sensitive Paper, thermometer.

What to do:

1. Fill a round-bottomed flask with water and set it up on its circular base in front of the radiant heater.
2. Place the heat-sensitive paper behind the flask about one radius distant. Does the paper discolour? Does the water absorb heat?
3. Use the lens to focus heat radiation on the paper.
4. Fires have been started by sunlight focused on paper or fabric. Discuss.

Equipment:

Heat Sensitive Paper, adhesive-backed: Educational Innovations, HEA-200, US\$24.95.

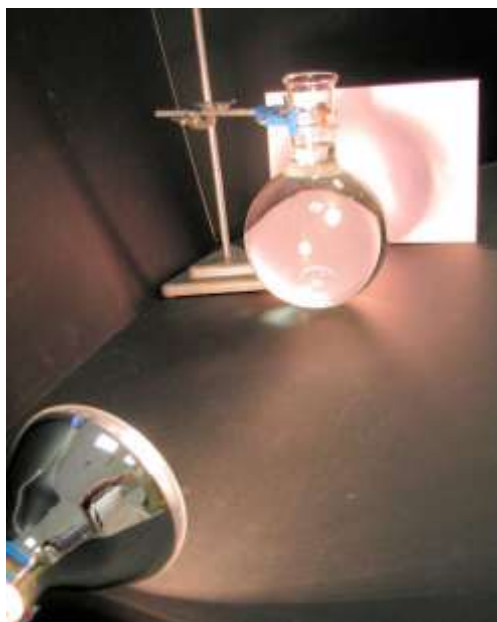

As you see from the photograph the flask acts as a shadow mask. The heating effect of the lamp's radiation can be seen around the shadow's edge.

IRR: The seasons

Purpose: To show the differences in seasonal heating of the Earth because of the tilt in its spin axis.

Information: The seasons are explained by a model of the Earth orbiting around the Sun, which it does once a year. A radiant heater, preferably one that radiates in all directions, represents the Sun. A globe represents the Earth. It should be moved in a horizontal plane around the radiant heater, stopping at places representing the position of the Earth at summer and winter solstices, and spring and autumn equinoxes. The polar axis of the Earth, the one around which the Earth revolves daily, shall point at an inclination of 23.5° to the vertical. Its direction shall remain constant. At the start of the demonstration, the direction of the polar axis is set by inclining the Northern Hemisphere towards the Sun. This represents summer in northern latitudes.

Cut the heat-sensitive paper into many segments to form a globe, or cover one such that when placed on the globe or ball the spherical surface is covered. Place the globe in the radiation such that the Northern Hemisphere is tilted towards the source. Leave until the paper is discoloured. The heating effect is seen to be biased towards northern latitudes. Move the globe to the opposite side of the radiant heater (if the radiation is directional the heater shall be turned around to point in the opposite direction), taking care to ensure that the direction of the spin axis of the globe remains unchanged. Now the heating effect is seen to be biased towards southern latitudes.

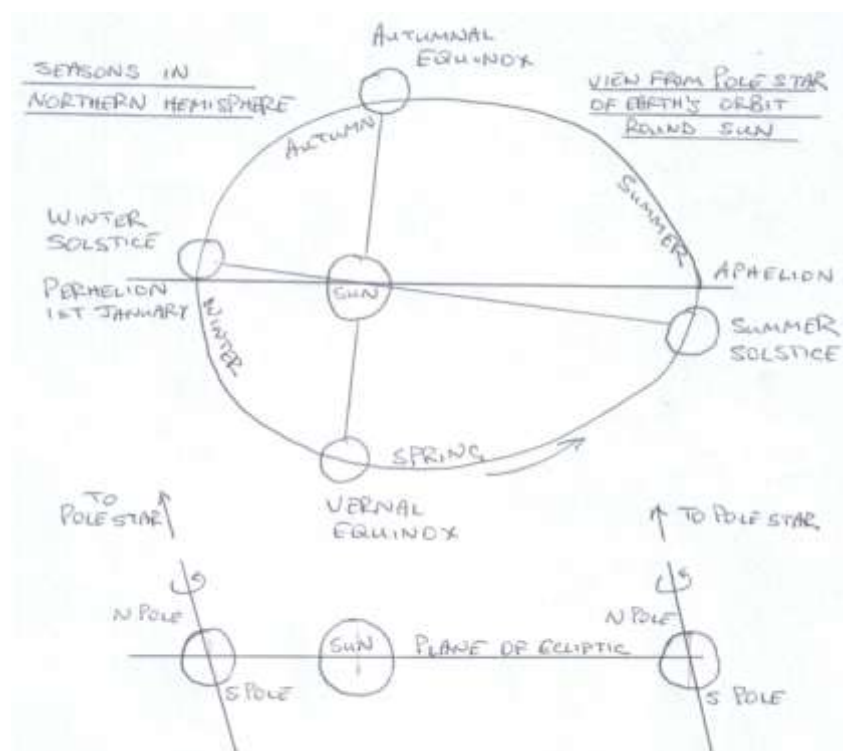

TOP:
Plane of Earth's orbit around Sun showing their positions at four times of the year for the Northern Hemisphere.

BOTTOM:
Section through orbit showing the inclination of the polar axis in winter (left) and summer (right) for the Northern Hemisphere.

What you need: Globe or large ball with an axle through its centre, heat-sensitive paper (adhesive-backed), scissors, radiant heater.

What to do:

1. Mark out a circle around the radiant heater. This stands for the path of the Earth as it orbits the Sun.
2. Place the globe at some point on this circle. The Northern Hemisphere should be tilted towards the radiant heater. Allow the globe to be irradiated by heat until the paper surface becomes discoloured. Note that the heating effect is biased towards northern latitudes.

3. Move the globe to the opposite side of the radiant heater ensuring that the polar axis does not change direction. Allow the globe to be reheated. Note the difference in heating effect.
4. To complete the demonstration, move the globe one quarter of the way round the circle. Allow to be heated. Both Hemispheres experience equal heating.
5. Throughout the demonstration, refer to the Pole Star. The polar axis is directed towards it, a distant object in the heavens.

Equipment:

Heat Sensitive Paper, adhesive-backed: Educational Innovations, HEA-200, US\$24.95; or Thermocolour Sheet: MUTR, IT9 001A, £22.39.

Radiant Heater, Electrosond, 230 V, 400 W (radiates in all directions).

We have made globes with Heat Sensitive Paper and Thermocolour Paper. Neither was found to give a startlingly-good colour change on being exposed to heat radiation, but, of the two materials, the former was judged to be the better.

To make a globe (radius R), cut the paper into 24 isosceles triangles whose height is three times longer than the base. Each hemisphere is made from fitting together 12 triangles (height = $\pi R/2$; base = $\pi R/6$). The long sides of the triangles should curve slightly outwards. We found it easier to make our globe entirely with paper than to try to cover a ball with paper. A suitable diameter is 12 cm ($R = 6$ cm).

Therefore the triangles should have a nominal height of 9 cm and base of 3 cm.

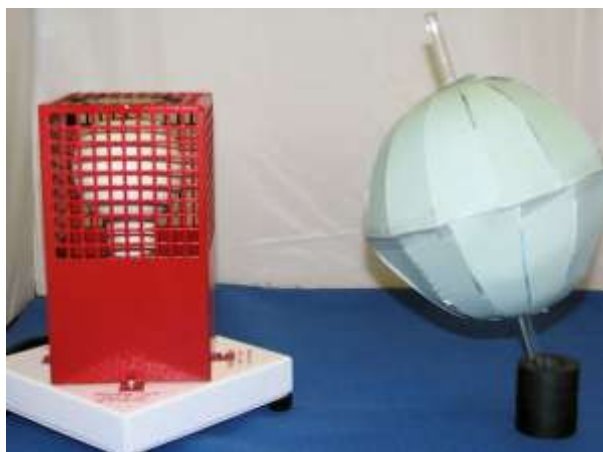

Globe made with Heat-Sensitive Paper.

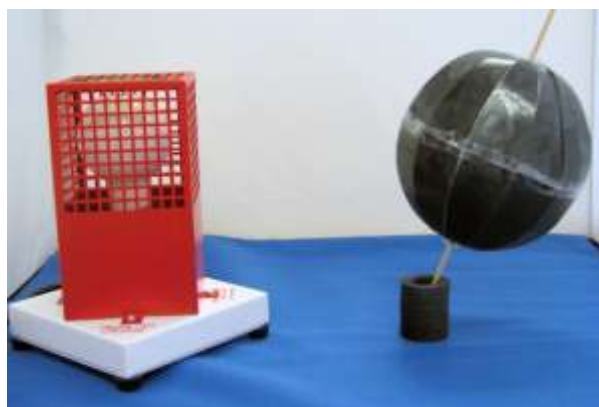

Globe made with Thermocolour Sheet.

Questions:

1. What is the latitude of (a) your school? (b) the Tropic of Cancer?
2. To the nearest degree what is the midday altitude of the Sun at your school on
 - a. 21st March?
 - b. 21st April?
 - c. 21st May?
 - d. 21st June?
3. To the nearest degree what is the midday altitude of the Pole Star at your school on these dates?

HEALTH AND SAFETY

Optical, UV and IR hazards – Summary table

Radiation Type	Waveband	Retinal photo-chemical damage (Blue-light hazard)	Retinal thermal damage	Cataract formation	Corneal damage	Erythema (reddening of the skin)	Carcinogenesis (skin cancer)
Ultraviolet C	100–280 nm				Cornea and ocular tissue at risk of photokeratitis (snow blindness) (arc eye)	Erythema can result from over-exposure	Probably carcinogenic to humans
Ultraviolet B	280-315 nm						
Ultraviolet A	315-400 nm	Blue-light hazard between 380 nm and 590 nm.		Lens of eye at risk of damage from cataracts		Only at very high radiant exposures	
Visible	400-700 nm	No risk below a radiance threshold; risk is independent of image size	No risk below a radiance threshold; risk depends on image size;				
Infrared A	700-1400 nm		significant risk with Infrared A because it is invisible	Lens of eye at risk of damage from cataracts			
Infrared B	1400-3000 nm					Corneal burns	
Infrared C	3 μm – 1 mm						

Risks from exposure to ultraviolet and visible radiation:

1. Solar radiation is carcinogenic to humans (Group 1 carcinogen, ie there is sufficient evidence in humans for the carcinogenicity of solar radiation).
2. UVA radiation if incident on the skin is probably carcinogenic to humans (Group 2A carcinogen, i.e. there is limited evidence of carcinogenicity in humans and sufficient evidence of carcinogenicity in experimental animals).
3. UVB radiation is probably carcinogenic to humans (Group 2A carcinogen).
4. UVC radiation is probably carcinogenic to humans (Group 2A carcinogen).
5. If incident on the skin, photosensitization can occur.
6. If incident on the eye, the cornea transmits UVA. The lens absorbs strongly, allowing the rest (about 1%) to reach the retina. There is a risk of cataract formation. Chronic exposure prematurely ages the lens. The retina can be damaged by violet or blue radiation (380 to 550 nm) producing lesions. The threshold for this effect, called 'blue-light photoretinitis' depends jointly on light intensity and exposure period. It varies from one individual to another.

Optical Sources – A summary of control measures and guidance

The table below is designed to be a quick reference guide to precautions that should be taken using sources of optical radiation in schools. We suggest referring to the main text in our new guide called 'Optical Radiations' in all cases.

Source	Control measures	Guidance to users
Ray box (tungsten)		Teachers should look out for pupils deliberately staring at the bulb and warn them if they do so.
Discharge tube (spectral lamp) (This section does not apply to mercury tubes designed to emit UV)		Avoid staring at lamp, taking particular care if the lamp emits significant amounts of short wavelength (e.g. blue) light.
LED, visible, indicator type		Indicator LEDs are considered safe
LED, visible, high power	Blue high power LEDs should be clamped or secured	Do not stare at the LED - particularly important for short wavelength LEDs, e.g. blue Lumileds. Refer to SSERC guide, 'Optical Radiation', for maximum exposure times (blue or white).
LED, UVA	Clamp and direct away from persons	Do not stare at the LED. Avoid irradiating the skin.
LED, UVB or UVC	Clamp and direct away from persons, or enclose.	Do not irradiate the eye or skin. Beware of reflections.
LED, infrared, low power		Low-power infrared LEDs are considered safe.
UV-A lamp	Clamp lamps in place or use a light box.	Do not stare at the lamp. Avoid irradiating the skin. Beware of reflections.
UV-C lamp	Lamp must have a shroud.	Do not stare at the lamp. Do not irradiate the skin. Beware of reflections. Refer to main text for maximum exposure times.
Laser	Class 1 or 2 only, not 1M, 2M, 3R, 3B or 4. Clamp securely if using a small device e.g. a laser diode module. Use a beam stop.	Do not stare into the beam. Do not aim the beam at another person. Limits apply to laser pointers too. Do not use unclassified laser pointers. Do not use laser pointers for experiments.
Car headlight bulb	Use behind glass cover or with a shroud.	Gives out UV, so if not used with glass cover, avoid irradiating skin and do not look directly at it. If used with a glass cover, do not stare at the source.

Reference

'Optical Radiation – Safe Use', SSERC, 2010

http://www.sserc.org.uk/members/SafetyNet/Physics/SSERC_Optical_radiation_safe_use.pdf